



SERVICE MANUAL

E1152

WEB ACCESS: <http://www.yorkville.com>

WORLD HEADQUARTERS CANADA

Yorkville Sound
550 Granite Court
Pickering, Ontario
L1W-3Y8 CANADA

Voice: (905) 837-8481
Fax: (905) 837-8746

U.S.A.

Yorkville Sound Inc.
4625 Witmer Industrial Estate
Niagara Falls, New York
14305 USA

Voice: (716) 297-2920
Fax: (716) 297-3689



Quality and Innovation Since 1963
Printed in Canada

IMPORTANT SAFETY INSTRUCTIONS



This lightning flash with arrowhead symbol, within an equilateral triangle, is intended to alert the user to the presence of uninsulated "dangerous voltage" within the product's enclosure that may be of sufficient magnitude to constitute a risk of electric shock to persons.

Ce symbole d'éclair avec tête de flèche dans un triangle équilatéral est prévu pour alerter l'utilisateur de la présence d'un « voltage dangereux » non-isolé à proximité de l'enceinte du produit qui pourrait être d'ampleur suffisante pour présenter un risque de choc électrique.



CAUTION AVIS

**RISK OF ELECTRIC SHOCK
DO NOT OPEN**

**RISQUE DE CHOC ELECTRIQUE
NE PAS OUVRIR**



The exclamation point within an equilateral triangle is intended to alert the user to the presence of important operating and maintenance (servicing) instructions in the literature accompanying the appliance.

Le point d'exclamation à l'intérieur d'un triangle équilatéral est prévu pour alerter l'utilisateur de la présence d'instructions importantes dans la littérature accompagnant l'appareil en ce qui concerne l'opération et la maintenance de cet appareil.



SZ125A

FOLLOW ALL INSTRUCTIONS

**Instructions pertaining to a risk of fire,
electric shock, or injury to a person**

**CAUTION: TO REDUCE THE RISK OF ELECTRIC
SHOCK, DO NOT REMOVE COVER (OR BACK).**

NO USER SERVICEABLE PARTS INSIDE.

**REFER SERVICING TO QUALIFIED
SERVICE PERSONNEL.**

SUIVEZ TOUTES LES INSTRUCTIONS

**Instructions relatives au risque de feu,
choc électrique, ou blessures aux personnes**

**AVIS: AFIN DE REDUIRE LES RISQUE DE CHOC
ELECTRIQUE, N'ENLEVEZ PAS LE COUVERT (OU LE
PANNEAU ARRIERE) NE CONTIENT AUCUNE PIECE**

REPARABLE PAR L'UTILISATEUR.

**CONSULTEZ UN TECHNICIEN QUALIFIE
POUR L'ENTRETIEN**

Read Instructions: The Owner's Manual should be read and understood before operation of your unit. Please, save these instructions for future reference and heed all warnings.

Clean only with dry cloth.

Packaging: Keep the box and packaging materials, in case the unit needs to be returned for service.

Warning: To reduce the risk of fire or electric shock, do not expose this apparatus to rain or moisture. *Do not use this apparatus near water!*

Warning: When using electric products, basic precautions should always be followed, including the following:

Power Sources

Your unit should be connected to a power source only of the voltage specified in the owners manual or as marked on the unit. This unit has a polarized plug. Do not use with an extension cord or receptacle unless the plug can be fully inserted. Precautions should be taken so that the grounding scheme on the unit is not defeated. An apparatus with CLASS I construction shall be connected to a Mains socket outlet with a protective earthing ground. Where the MAINS plug or an appliance coupler is used as the disconnect device, the disconnect device shall remain readily operable.

Hazards

Do not place this product on an unstable cart, stand, tripod, bracket or table. The product may fall, causing serious personal injury and serious damage to the product. Use only with cart, stand, tripod, bracket, or table recommended by the manufacturer or sold with the product. Follow the manufacturer's instructions when installing the product and use mounting accessories recommended by the manufacturer. Only use attachments/accessories specified by the manufacturer

Note: Prolonged use of headphones at a high volume may cause health damage on your ears.

The apparatus should not be exposed to dripping or splashing water; no objects filled with liquids should be placed on the apparatus.

Terminals marked with the "lightning bolt" are hazardous live; the external wiring connected to these terminals require installation by an instructed person or the use of ready made leads or cords.

Ensure that proper ventilation is provided around the appliance. Do not install near any heat sources such as radiators, heat registers, stoves, or other apparatus (including amplifiers) that produce heat.

No naked flame sources, such as lighted candles, should be placed on the apparatus.

Power Cord

Do not defeat the safety purpose of the polarized or grounding-type plug. A polarized plug has two blades with one wider than the other. A grounding type plug has two blades and a third grounding prong. The wide blade or the third prong are provided for your safety. If the provided plug does not fit into your outlet, consult an electrician for replacement of the obsolete outlet. The AC supply cord should be routed so that it is unlikely that it will be damaged. Protect the power cord from being walked on or pinched particularly at plugs. If the AC supply cord is damaged DO NOT OPERATE THE UNIT. To completely disconnect this apparatus from the AC Mains, disconnect the power supply cord plug from the AC receptacle. The mains plug of the power supply cord shall remain readily operable.

Unplug this apparatus during lightning storms or when unused for long periods of time.

Service

The unit should be serviced only by qualified service personnel. Servicing is required when the apparatus has been damaged in any way, such as power-supply cord or plug is damaged, liquid has been spilled or objects have fallen into the apparatus, the apparatus has been exposed to rain or moisture, does not operate normally, or has been dropped.

Veillez Lire le Manuel: Il contient des informations qui devraient être comprises avant l'opération de votre appareil. Conservez. Gardez S.V.P. ces instructions pour consultations ultérieures et observez tous les avertissements.

Nettoyez seulement avec le tissu sec.

Emballage: Conservez la boîte au cas où l'appareil devait être retourner pour réparation.

Avertissement: Pour réduire le risque de feu ou la décharge électrique, n'exposez pas cet appareil à la pluie ou à l'humidité. *N'utilisez pas cet appareil près de l'eau!*

Attention: Lors de l'utilisation de produits électrique, assurez-vous d'adhérer à des précautions de bases incluant celle qui suivent:

Alimentation

L'appareil ne doit être branché qu'à une source d'alimentation correspondant au voltage spécifié dans le manuel ou tel qu'indiqué sur l'appareil. Cet appareil est équipé d'une prise d'alimentation polarisée. Ne pas utiliser cet appareil avec un cordon de raccordement à moins qu'il soit possible d'insérer complètement les trois lames. Des précautions doivent être prises afin d'éviter que le système de mise à la terre de l'appareil ne soit désengagé. Un appareil construit selon les normes de CLASS I devrait être raccordé à une prise murale d'alimentation avec connexion intacte de mise à la masse. Lorsqu'une prise de branchement ou un coupleur d'appareils est utilisée comme dispositif de débranchement, ce dispositif de débranchement devra demeurer pleinement fonctionnel avec raccordement à la masse.

Risque

Ne pas placer cet appareil sur un chariot, un support, un trépied ou une table instables. L'appareil pourrait tomber et blesser quelqu'un ou subir des dommages importants. Utiliser seulement un chariot, un support, un trépied ou une table recommandés par le fabricant ou vendus avec le produit. Suivre les instructions du fabricant pour installer l'appareil et utiliser les accessoires recommandés par le fabricant. Utilisez seulement les attachments/accessoires indiqués par le fabricant

Note: L'utilisation prolongée des écouteurs à un volume élevé peut avoir des conséquences néfastes sur la santé sur vos oreilles. .

Il convient de ne pas placer sur l'appareil de sources de flammes nues, telles que des bougies allumées.

L'appareil ne doit pas être exposé à des égouttements d'eau ou des éclaboussures et qu'aucun objet rempli de liquide tel que des vases ne doit être placé sur l'appareil.

Assurez que l'appareil est fourni de la propre ventilation. Ne procédez pas à l'installation près de source de chaleur tels que radiateurs, registre de chaleur, fous ou autres appareils (incluant les amplificateurs) qui produisent de la chaleur.

Les dispositifs marqués d'une symbole "d'éclair" sont des parties dangereuses au toucher et que les câblages extérieurs connectés à ces dispositifs de connexion extérieure doivent être effectués par un opérateur formé ou en utilisant des cordons déjà préparés.

Cordon d'Alimentation

Ne pas enlever le dispositif de sécurité sur la prise polarisée ou la prise avec tige de mise à la masse du cordon d'alimentation. Une prise polarisée dispose de deux lames dont une plus large que l'autre. Une prise avec tige de mise à la masse dispose de deux lames en plus d'une troisième tige qui connecte à la masse. La lame plus large ou la tige de mise à la masse est prévu pour votre sécurité. La prise murale est désuète si elle n'est pas conçue pour accepter ce type de prise avec dispositif de sécurité. Dans ce cas, contactez un électricien pour faire remplacer la prise murale. Évitez d'endommager le cordon d'alimentation. Protégez le cordon d'alimentation. Assurez-vous qu'on ne marche pas dessus et qu'on ne le pince pas en particulier aux prises. **N'UTILISEZ PAS L'APPAREIL** si le cordon d'alimentation est endommagé. Pour débrancher complètement cet appareil de l'alimentation CA principale, déconnectez le cordon d'alimentation de la prise d'alimentation murale. Le cordon d'alimentation du bloc d'alimentation de l'appareil doit demeurer pleinement fonctionnel.

Débranchez cet appareil durant les orages ou si inutilisé pendant de longues périodes.

Service

Consultez un technicien qualifié pour l'entretien de votre appareil. L'entretien est nécessaire quand l'appareil a été endommagé de quelque façon que se soit. Par exemple si le cordon d'alimentation ou la prise du cordon sont endommagés, si il y a eu du liquide qui a été renversé à l'intérieur ou des objets sont tombés dans l'appareil, si l'appareil a été exposé à la pluie ou à l'humidité, si il ne fonctionne pas normalement, ou a été échappé.

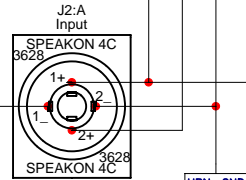
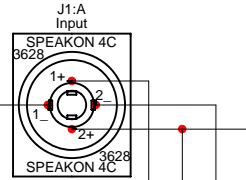
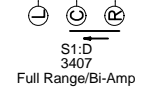
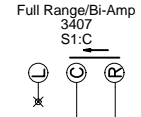
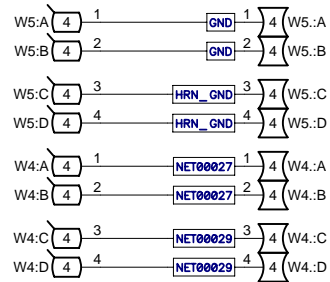

HRN_GND

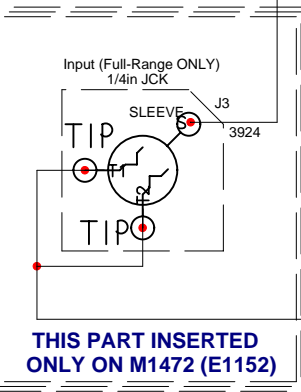

THIS PART INSERTED ONLY ON M1472 (E1152)

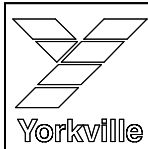
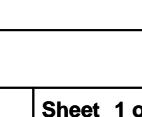
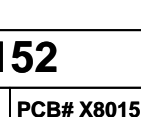
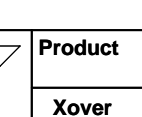
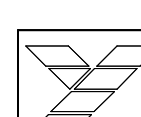
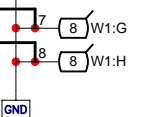
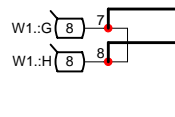
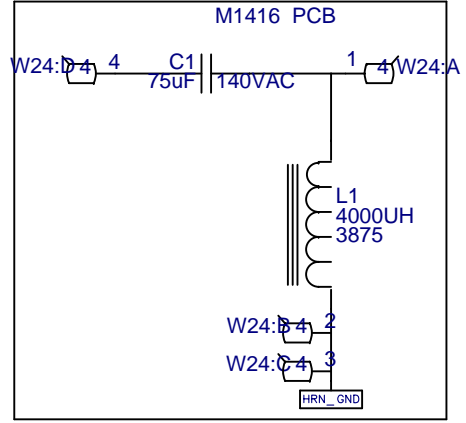
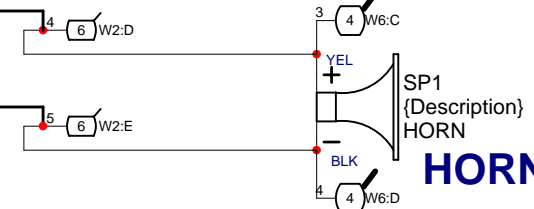
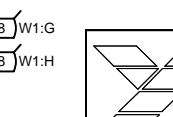
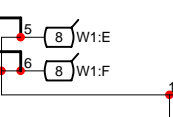
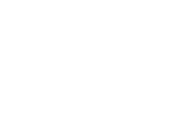
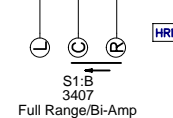
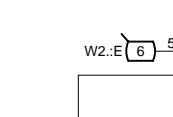
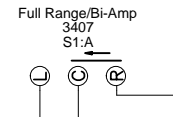
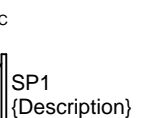
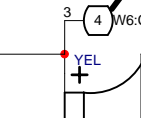
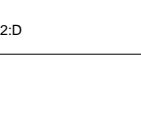
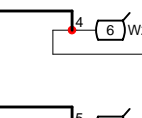
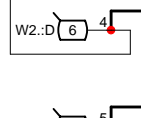
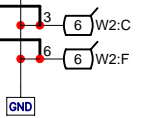
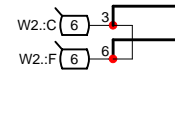
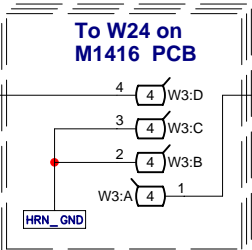
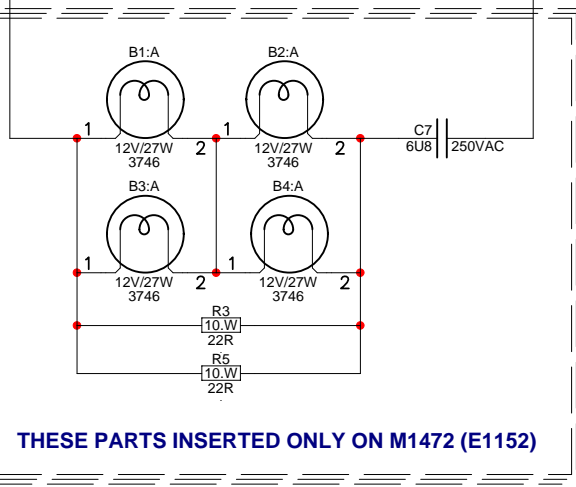
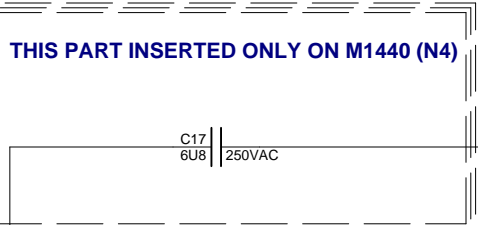
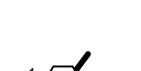
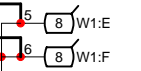
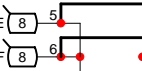
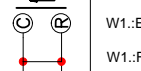
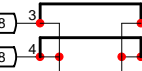
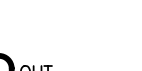
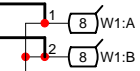
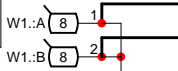
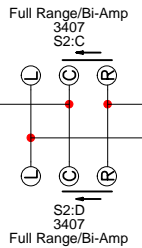

Product N4/E1152		
Xover	PCB# X8015	Sheet 1 of 1
Date: Tue Jan 26, 2010	Rev:V2.00	YsType:YsType
Filename: X8015V200sch.sch2002		



SEE LAYOUT DIAGRAM



M1472 PRODUCTION NOTES

1. RTV MUST BE ADDED TO R3 AND R5 BEFORE THEY ARE INSERTED INTO THE BOARD (SEE ASSEMBLY DRAWING)

2. RTV MUST BE ADDED GENEROUSLY TO THE TOPS OF R3 AND R5 BEFORE BULBS B1, B2, B3, AND B4 ARE INSERTED (SEE ASSEMBLY DRAWING)

3. RTV MUST BE ADDED TO THE FOLLOWING CAPS C2, C3, C4, C5, C6, C7

4. RTV MUST BE ADDED TO THE FOLLOWING INDUCTORS L2, L3, L4, L5, L6

5. RTV MUST BE ADDED TO THE FOLLOWING RESISTORS R1, R2, R4, R6, R7, R8

6. AFTER WAVE SOLDERING, BREAK OFF INCORRECT BOARD NUMBER TAB AT BOTTOM EDGE OF THE PANEL AS INDICATED ON DRAWING (BREAK ME)

7. TIE-WRAP L4, L5, L6, C4, C5, C6 USING ROUTING/HOLES ON BOARD

8. BOLT L2 TO BOARD USING 3853, 3515, AND 3855. 3853 MUST BE INSERTED FROM TOP OF COIL (3855 MUST BE ON BOTTOM SIDE OF BOARD)

9. BOLT L3 TO BOARD USING 3854 AND 3855

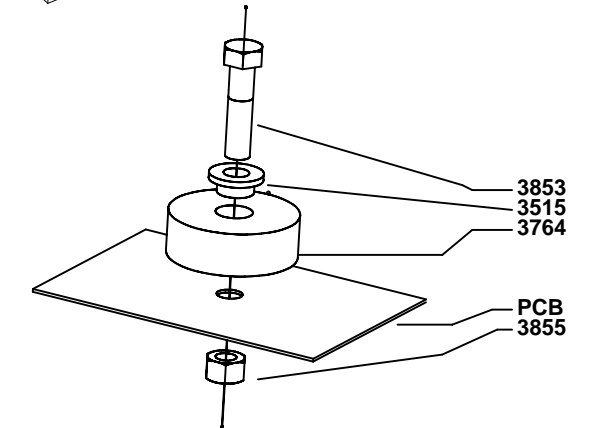
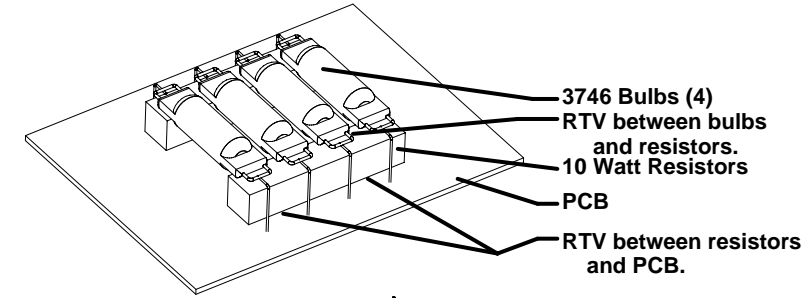

X8015 PCB HISTORY			
MODEL(S):-		N4/E502	
#	DATE	VER#	DESCRIPTION OF CHANGE
1	May 2009	1.00p0	First Prototype
2	June 2009	1.00p1	Second Prototype; Added 1/4" for Elite, value changes
3	JULY 2009	1V00	First Production Issue
4	20-JAN-2010	2V00	PC7943: Add material under W1, W2, W3. Rounded corners.
5	25-JAN-2010	.	PC7974: Replace capacitors C4, C5, C6 from #5444 to #5450
6	.	.	C2 from #5644 to #5447; C7, C17 from #5960 to #5449
7	.	.	PCxxx: Add R9 #6536 GG
8	D	V	N
9	D	V	N
10	D	V	N
11	D	V	N
12	D	V	N
13	D	V	N

X8015 PCB DRILLING HISTORY			
MODEL(S):-		N4/E502	
#	DATE	VER#	DESCRIPTION OF CHANGE
1	D	V	N
2	D	V	N
3	D	V	N
4	D	V	N
5	D	V	N
6	D	V	N

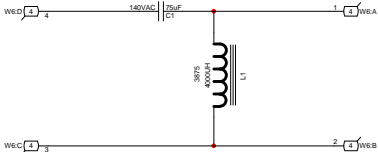

M1416 PCB_DATABASE_HISTORY

MODEL(S):-

C4

#	DATE	VER#	DESCRIPTION OF CHANGE
1	11-FEB-2009	1.00	FIRST DESIGN
2	26-FEB-2009	2.00	ADD #3538 TO THE BOARD
3	D	V	N
4	D	V	N
5	D	V	N
6	D	V	N
7	D	V	N
8	D	V	N
9	D	V	N
10	D	V	N
11	D	V	N
12	D	V	N
13	D	V	N



Product **C4**

Sheet1

PCB# M1416

Sheet 1 of 1

Date: Thu Feb 26, 2009

Rev: 2.00

YsType: YsType

Filename: M1416V200sch.sch2002

BlankSize - 11500x9000

score

ClinchRepeats - X2@5375Y2@4200

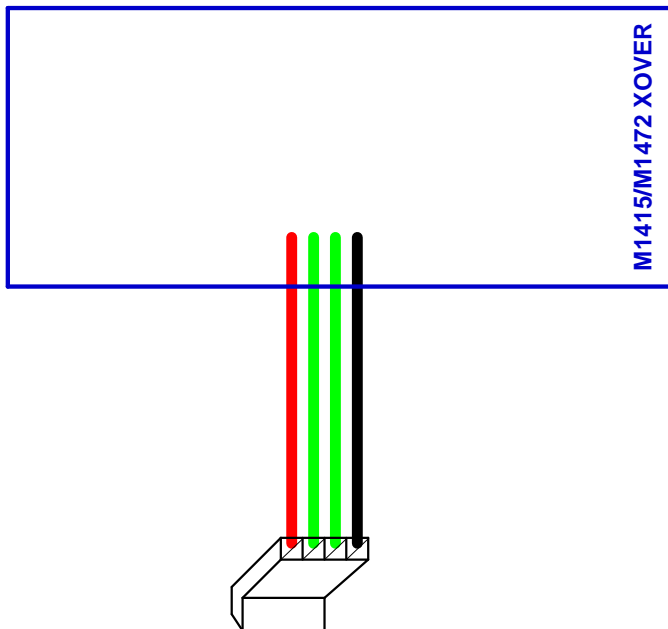

score

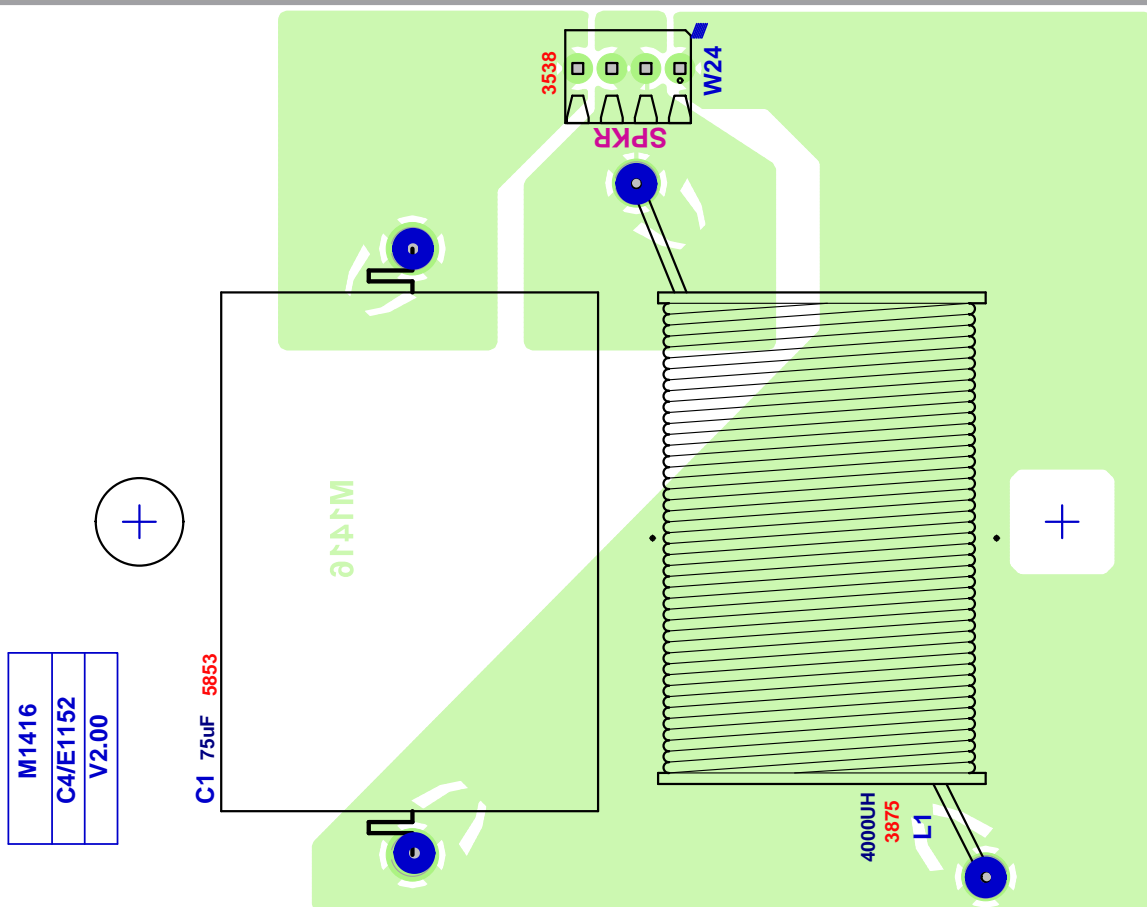

score

2ozCopper 2ozCopper

score

SEE LAYOUT DOCUMENTATION



SEE LAYOUT DIAGRAM



M1416 PRODUCTION NOTES

1. LITTLE BIT OF RTV UNDER C1 AND L1 AND PUSH COIL AND CAP CLOSE TOGETHER AND MAKE SURE THE COIL IS WITHIN THE BOX LEGEND.
2. NO CABLE TIE FOR C1 AND L1
3. PUT #8383 GRAY FOAM TOP OF THE C1 AND L1 UNDER METAL BRACKET, Z1085
4. USE #8806, 6-32 SCREW AND #8800 KEP NUT FOR TERMINAL SRTIP 5P AND METAL BRACKET
5. BEND C1 AND L1 LEADS OVER THE TEAR DROP PADS.

M1416 PCB_DATABASE_HISTORY			
MODEL(S):- C4/E1152			
#	DATE	VER#	DESCRIPTION OF CHANGE
1	11-FEB-2009	1.00	FIRST DESIGN
2	26-FEB-2009	2.00	ADD #3538 TO THE BOARD
3	D	V	N
4	D	V	N
5	D	V	N
6	D	V	N
7	D	V	N
8	D	V	N
9	D	V	N
10	D	V	N
11	D	V	N
12	D	V	N
13	D	V	N
M1416			
MODEL(S):- C4/E1152			
#	DATE	VER#	DESCRIPTION OF CHANGE
1	D	V	N
2	D	V	N
3	D	V	N
4	D	V	N
5	D	V	N
6	D	V	N
M1416 PENDING CHANGES			
MODEL(S):- C4/E1152			
#	PC#	PENDING CHANGE	
1	PC	X	
2	PC	X	
3	PC	X	
4	PC	X	
5	PC	X	
6	PC	X	

*PLACE IMPLEMENTED CHANGES INTO BOARD HISTORY