

YAMAHA PORTATONE **PSR-6700**

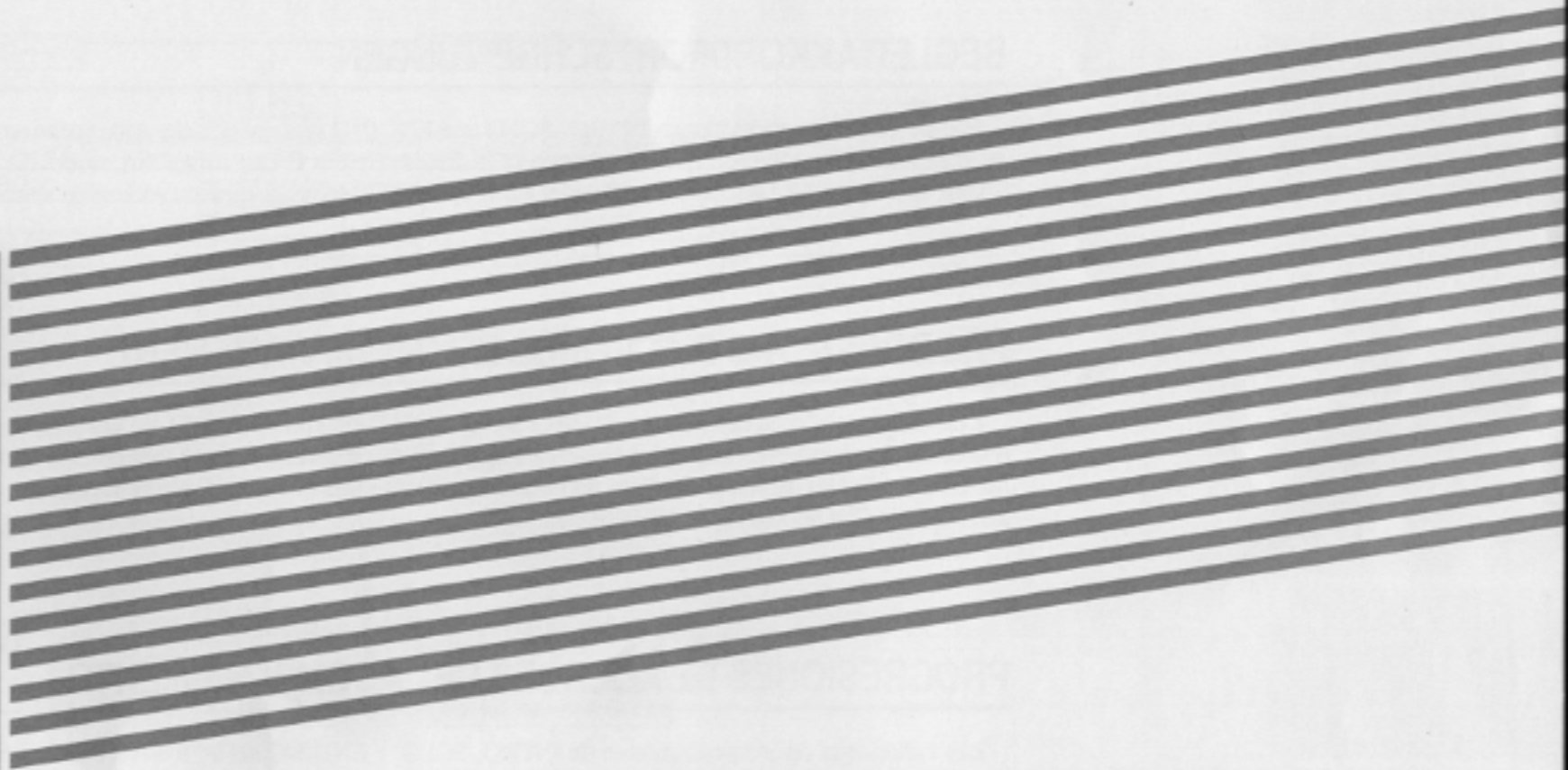

Accompaniment Chord Progressions
Begleitakkordfortschreitungen
Progressions d'accords d'accompagnement
Progresiones de acordes del acompañamiento

ACCOMPANIMENT CHORD PROGRESSIONS

The PSR-6700 INTRO, SOLO, and ENDING accompaniment variations have pre-programmed chord progressions. The programmed chord progressions are all listed here in the key of C, although the actual key used will depend on the chords you play in the Fingered Chord, or Single Finger ABC modes.

BEGLEITAKKORDFORTSCHREITUNGEN

Für die Begleitungsvariationen INTRO, SOLO und ENDING sind spezifische Akkordfortschreitungen programmiert. Die Akkordfortschreitungen sind in diesem Heft in C-Dur aufgeführt, wobei die tatsächliche Tonart jedoch von den im Akkordgriff- oder Einfinger-ABC-Modus gespielten Akkorden abhängt.

PROGRESSIONS D'ACCORDS D'ACCOMPAGNEMENT

Les variations d'accompagnement INTRO, SOLO et ENDING du PSR-6700 ont des progressions d'accords programmées. Toutes les progressions d'accords programmées sont indiquées ci-après en clef de do, bien que la clef réellement utilisée dépende des accords joués en mode d'accompagnement automatique FINGERED CHORD ou SINGLE FINGER.

PROGRESIONES DE ACORDES DEL ACOMPAÑAMIENTO

Las variaciones de acompañamiento de INTRO, SOLO, y ENDING del PSR-6700 tienen progresiones de acordes preprogramadas. Las progresiones de acordes programadas están listadas aquí en la clave de C, aunque la clave actualmente utilizada dependerá de los acordes que usted toque en los modos ABC de acordes digitados o de un solo dedo.

ABC/IA Accompaniment Flow Diagram

Ablaufdiagramm für automatische Baß-/Akkordbegleitung und interaktive Begleitung

Schéma de principe de l'accompagnement IA/Automatique

Diagrama de flujo de acompañamiento ABC/IA

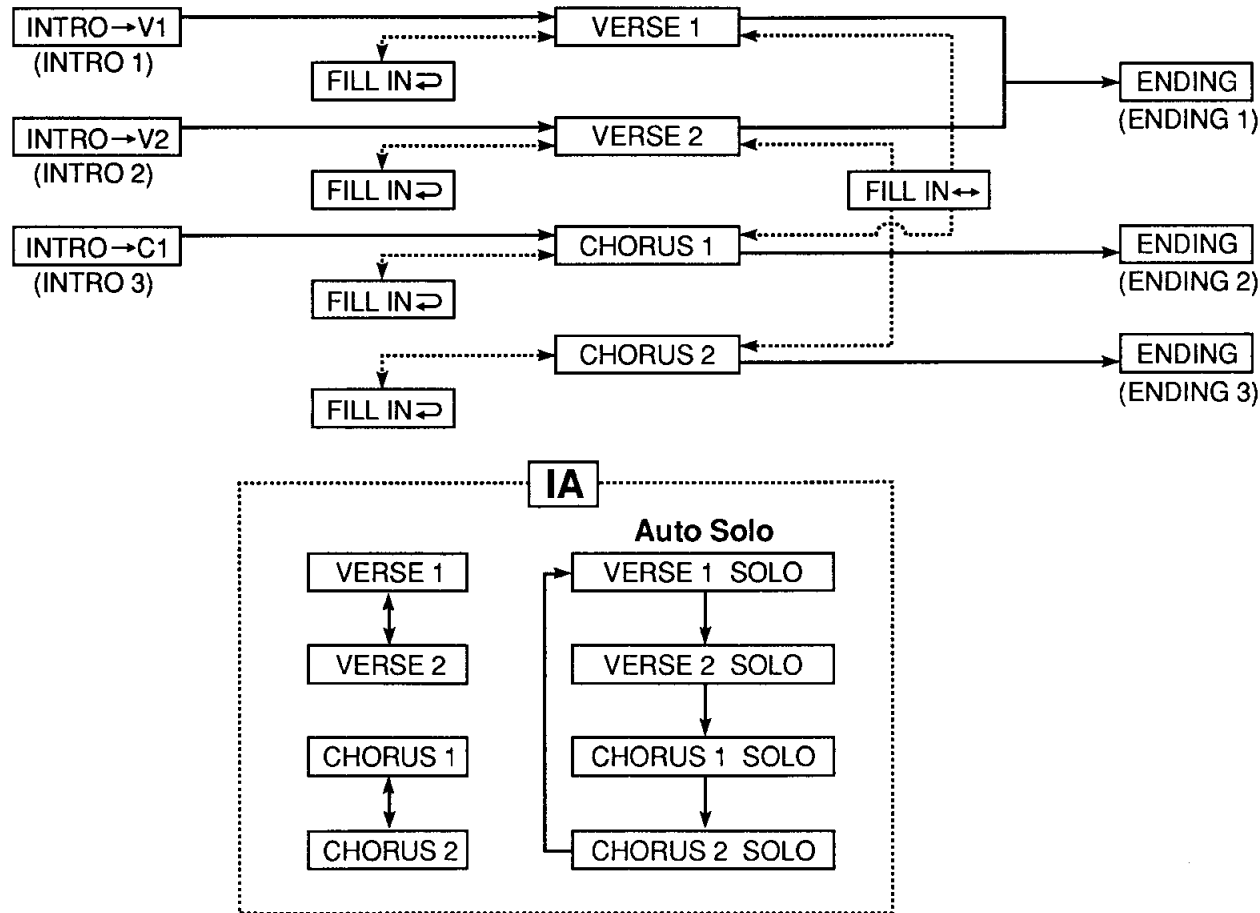

- BANK 0**
- 01 DANCE POP
 - 02 PARTY POP
 - 03 ROCK
 - 04 ROCK&ROLL 1
 - 05 ROCK&ROLL 2

- BANK 1**
- 10 8 BEAT
 - 11 POP ROCK
 - 12 BOUNCE ROCK
 - 13 FOLK ROCK
 - 14 ROCK BALLAD
 - 15 PIANO BALLAD

- BANK 2**
- 20 SLOW ROCK
 - 21 SOUL ROCK
 - 22 SHUFFLE
 - 23 FUNK
 - 24 SWING
 - 25 BIG BAND

- BANK 3**
- 30 JAZZ BALLAD
 - 31 BOOGIE
 - 32 DIXIE
 - 33 WALTZ 1
 - 34 WALTZ 2
 - 35 JAZZ WALTZ

- BANK 4**
- 40 BOSSA NOVA
 - 41 SAMBA 1
 - 42 SAMBA 2
 - 43 RHUMBA
 - 44 TANGO
 - 45 CHA-CHA

- BANK 5**
- 50 REGGAE
 - 51 COUNTRY
 - 52 POLKA
 - 53 MARCH
 - 54 6/8 MARCH
 - 55 NEW AGE

- Disk Style**
- SET1 D1: HARD ROCK
D2: 6/8 ROCK
 - SET2 D1: SLOW ROCK 2
D2: LATINPOP
 - SET3 D1: R & B
D2: BOSSA NOVA 2
 - SET4 D1: SAMBA 3
D2: TANGO 2

STYLE: 00 EUROBEAT

INTRO PATTERN

INTRO 1	1st. measure		2nd. measure	
MAJOR			Rhythm only	

* Minor or 7th chords produce the same progression as major chords.

INTRO 2	1st. measure		2nd. measure		3rd. measure		4th. measure	
MAJOR	C		C		C		C	
MINOR	C _m		C _m		C _m		C _m	
7th	C ₇		C ₇		C ₇		C ₇	

INTRO 3	1st. measure		2nd. measure		3rd. measure		4th. measure		5th. measure		6th. measure		7th. measure		8th. measure	
MAJOR	C		C		$\frac{F\text{add9}}{C}$		$\frac{F}{C}$		C		C		$\frac{F\text{add9}}{C}$		$\frac{F}{C}$	
MINOR	C _m		C _m		$\frac{F}{C}$		$\frac{F}{C}$		C _m		C _m		$\frac{F}{C}$		$\frac{F}{C}$	

* 7th chords produce the same progression as major chords.

SOLO PATTERN

MAJOR	1st. measure		2nd. measure		3rd. measure		4th. measure		5th. measure		6th. measure		7th. measure		8th. measure	
VERSE 1	C		C		C		C		C		C		C		C	
VERSE 2	C		C		C		C		C		C		C		C	
CHORUS 1	C		F		F ₇		F		C		F		F ₇		F	
CHORUS 2	C		F	G	F ₇		F	$\frac{F}{G}$	C		F	G	F ₇		F	$\frac{F}{G}$

* Minor or 7th chords produce the same progression as major chords.

ENDING PATTERN

ENDING 1	1st. measure			2nd. measure			3rd. measure		
MAJOR	C			C			C	}	+
MINOR	C _m			C _m			C _m	}	+
7th	C ₇			C ₇			C ₇	}	+

ENDING 2	1st. measure			2nd. measure			3rd. measure		
MAJOR	C			C			C	}	+
MINOR	C _m			C _m			C _m	}	+
7th	C ₇			C ₇			C ₇	}	+

ENDING 3	1st. measure			2nd. measure		3rd. measure			4th. measure		5th. measure			6th. measure			7th. measure				
MAJOR	C			F	G	F ₇			F		$\frac{F_6}{G}$		C			C			C	}	+

* Minor or 7th chords produce the same progression as major chords.

STYLE: 01 DANCE POP

INTRO PATTERN

INTRO 1	1st. measure			2nd. measure		
MAJOR			Rhythm only			
7th		Rhythm only	C7			

* Minor chords produce the same progression as major chords.

INTRO 2	1st. measure			2nd. measure			3rd. measure			4th. measure		
MAJOR	C			C			C			C		
MINOR	Cm7			Cm7			Cm7			Cm7		
7th	C7			C7			C7			C7		

INTRO 3	1st. measure			2nd. measure			3rd. measure			4th. measure			5th. measure			6th. measure			7th. measure			8th. measure		
MAJOR	F	C	G	G	C	F	C	G	G	C	F	C	G	G	C	F	C	G						
MINOR	Cm	G7sus4	Cm	Fsus4	F	Cm	G7sus4	Cm	Fsus4	B ^b	Cm	G7sus4	Cm	Fsus4	F	Cm	G7sus4	Cm	G7sus4	B ^b				

* 7th chords produce the same progression as major chords.

SOLO PATTERN

MAJOR	1st. measure			2nd. measure			3rd. measure			4th. measure			5th. measure			6th. measure			7th. measure			8th. measure		
VERSE 1	C			C			C			C			C			C			C			C		
VERSE 2	C			C			B ^b		A ^m 7		G	C			C			G _{B^b}			F		D _G ^m	
CHORUS 1	E ^b		C				B ^b		C7		E ^b				C			B ^b			D _G ^m			
CHORUS 2	C		C				B ^b		F		G	C			C			B ^b			F		D _G ^m	

* Minor or 7th chords produce the same progression as major chords.

ENDING PATTERN

ENDING 1	1st. measure			2nd. measure			3rd. measure		
MAJOR	C			C			C		
MINOR	C _m			C _m			C _m		
7th	C ₇			C ₇			C ₇		

ENDING 2	1st. measure			2nd. measure			3rd. measure		
MAJOR	C			C					
MINOR	C _m			C _m					
7th	C ₇			C ₇					

ENDING 3	1st. measure			2nd. measure			3rd. measure			4th. measure			5th. measure				
MAJOR	F		G							G _{sus4}							

* Minor or 7th chords produce the same progression as major chords.

STYLE: 02 PARTY POP

INTRO PATTERN

INTRO 1	1st. measure				2nd. measure			
MAJOR	C				C			
MINOR	C _{m7}				C _{m7}			
7th	C ₇				C ₇			

INTRO 2	1st. measure				2nd. measure			
MAJOR	C				C			
MINOR	C _m				C _m			
7th	C ₇				C ₇			

INTRO 3	1st. measure			2nd. measure			3rd. measure			4th. measure		
MAJOR	G _{sus4}	C		B ^b / C	F		G _{sus4}	C		B ^b / C	F	

* Minor or 7th chords produce the same progression as major chords.

SOLO PATTERN

MAJOR	1st. measure				2nd. measure				3rd. measure				4th. measure				5th. measure				6th. measure				7th. measure				8th. measure			
VERSE 1	C ₇				F ₇				C ₇				F ₇				C ₇				F ₇				C ₇				F ₇			
VERSE 2	C	B ^b / G	C	B ^b / G	C	B ^b / G	C	B ^b / G	C	B ^b / G	C	B ^b / G	C	B ^b / G	C	B ^b / G	C	B ^b / G	C	B ^b / G	C	B ^b / G	C	B ^b / G	C	B ^b / G	C	B ^b / G	C	B ^b / G	C	B ^b / G
CHORUS 1	C ₇				C ₇				C ₇				C ₇				C ₇				C ₇				C ₇				C ₇			
CHORUS 2	C				E ^b				F				A ^b	B ^b	C		E ^b				F				A ^b				B ^b			

STYLE: 02 PARTY POP

MINOR	1st. measure				2nd. measure				3rd. measure				4th. measure				5th. measure				6th. measure				7th. measure				8th. measure											
VERSE 1	C _m				F ₇				C _m				F ₇				C _m				F ₇				C _m				F ₇											
VERSE 2	C	G _m	C	G _m	C	G _m	C	G _m	C	G _m	C	G _m	C	G _m	C	G _m	C	G _m	C	G _m	C	G _m	C	G _m	C	G _m	C	G _m	C	G _m	C	G _m	C	G _m	C	G _m	C	G _m	C	G _m
CHORUS 1	C		$\frac{F}{C}$		$\frac{B^b}{C}$		$\frac{F}{C}$		C		$\frac{F}{C}$		$\frac{B^b}{C}$		$\frac{F}{C}$		C		$\frac{F}{C}$		$\frac{B^b}{C}$		$\frac{F}{C}$		C		$\frac{F}{C}$		$\frac{B^b}{C}$		$\frac{F}{C}$		$\frac{B^b}{C}$		$\frac{F}{C}$					
CHORUS 2	C				E ^b				F				A ^b B ^b				C				E ^b				F				A ^b B ^b											

* 7th chords produce the same progression as major chords.

ENDING PATTERN

ENDING 1	1st. measure				2nd. measure			
MAJOR	C	$\frac{B^b}{G}$	C	$\frac{B^b}{G}$	C	$\frac{B^b}{G}$	C	+
MINOR	C _m		C _m		C _m	G _m 7	C _m	+

* 7th chords produce the same progression as major chords.

ENDING 2	1st. measure				2nd. measure			
MAJOR	C				C	B ^b C		+

* Minor or 7th chords produce the same progression as major chords.

ENDING 3	1st. measure				2nd. measure				3rd. measure				4th. measure				5th. measure							
MAJOR	C				E ^b				F				A ^b		B ^b		C				+			

* Minor or 7th chords produce the same progression as major chords.

STYLE: 03 ROCK

INTRO PATTERN

INTRO 1	1st. measure			
MAJOR	C			

* Minor or 7th chords produce the same progression as major chords.

INTRO 2	1st. measure		2nd. measure		3rd. measure		4th. measure	
MAJOR	C		C		C		C	
MINOR	C _m		C _m		C _m		C _m	
7th		Rhythm only			C ₇		C ₇	

INTRO 3	1st. measure		2nd. measure		3rd. measure		4th. measure		5th. measure	
MAJOR	C		E ^b		B ^b		G		G	Rhythm only

* Minor or 7th chords produce the same progression as major chords.

SOLO PATTERN

MAJOR	1st. measure		2nd. measure		3rd. measure		4th. measure		5th. measure		6th. measure		7th. measure		8th. measure	
VERSE 1	←						BREAK (DRUM SOLO)								→	
VERSE 2	←	C _m					BASS SOLO								→	
CHORUS 1	B ^b		F		C ₇			B ^b		F			C ₇			
CHORUS 2	B ^b		F		C ₇			B ^b		F			C ₇			

* Minor or 7th chords produce the same progression as major chords.

ENDING PATTERN

ENDING 1	1st. measure			2nd. measure			3rd. measure			4th. measure		
MAJOR	C			C			C			C		

* Minor or 7th chords produce the same progression as major chords.

ENDING 2	1st. measure			2nd. measure			3rd. measure		
MAJOR	C		B ^b			C		┐	
MINOR	C _m		B ^b			C _m		┐	
7th	C ₇			C ₇				┐	

ENDING 3	1st. measure			2nd. measure			3rd. measure			4th. measure		
MAJOR	C			C			C			Rhythm only		
MINOR	C _m			C _m			C _m			Rhythm only		
7th	C ₇			F	C ₇		C			Rhythm only		

STYLE: 04 ROCK&ROLL 1

INTRO PATTERN

INTRO 1	1st. measure				2nd. measure			
MAJOR								
	Rhythm only							

* Minor or 7th chords produce the same progression as major chords.

INTRO 2	1st. measure				2nd. measure				3rd. measure				4th. measure			
MAJOR	C				C				C				C			
MINOR	C _m				C _m				C _m				C _m			
7th	C ₇				C ₇				C ₇				C ₇			

INTRO 3	1st. measure				2nd. measure				3rd. measure				4th. measure			
MAJOR	G ₇				F ₇				C ₇				C ₇			

* Minor or 7th chords produce the same progression as major chords.

SOLO PATTERN

MAJOR	1st. measure				2nd. measure				3rd. measure				4th. measure				5th. measure				6th. measure				7th. measure				8th. measure			
VERSE 1	C ₆				C ₆				C ₆				C ₆				C _m				C _m				C _m				C _m			
VERSE 2	C ₇				C ₇				C ₇				C ₇				C ₇				C ₇				C ₇				C ₇			
CHORUS 1	C ₇				C ₇				C ₇				C ₇				F ₇				F ₇				C ₇				C ₇			
CHORUS 2	G ₇				F ₇				C ₇				G ₇				G ₇				F ₇				C ₇				G ₇			

* Minor or 7th chords produce the same progression as major chords.

ENDING PATTERN

ENDING 1	1st. measure			2nd. measure		
MAJOR	C ₆			G		
MINOR	C _m			C _m	$\frac{F}{C}$ C _m	
7th	C ₇			$\frac{C_7}{G}$	B C	

ENDING 2	1st. measure			2nd. measure		
MAJOR	C			C		
MINOR	C _m			C _m		
7th	C ₇			C ₇		C

ENDING 3	1st. measure			2nd. measure			3rd. measure			4th. measure			5th. measure		
MAJOR	G ₇			F ₇			C ₇			C ₆					

* Minor or 7th chords produce the same progression as major chords.

STYLE: 05 ROCK&ROLL 2

INTRO PATTERN

INTRO 1	1st. measure			
MAJOR	C7			

* Minor or 7th chords produce the same progression as major chords.

INTRO 2	1st. measure				2nd. measure				3rd. measure				4th. measure			
MAJOR	C7				C7				C7				C7			

* Minor or 7th chords produce the same progression as major chords.

INTRO 3	1st. measure				2nd. measure				3rd. measure				4th. measure			
MAJOR	G7				F7				C7				G			

* Minor or 7th chords produce the same progression as major chords.

SOLO PATTERN

MAJOR	1st. measure				2nd. measure				3rd. measure				4th. measure				5th. measure				6th. measure				7th. measure				8th. measure			
VERSE 1	C7				C7				C7				C7				C7				C7				C7				C7			
VERSE 2	C7				C7				C7				C7				C7				C7				C7				C7			
CHORUS 1	C7				C7				C7				C7				C7				C7				C7				C7			
CHORUS 2	C				C				F7				F7				G7				G7				C				G7			

* Minor or 7th chords produce the same progression as major chords.

ENDING PATTERN

ENDING 1	1st. measure				2nd. measure				3rd. measure			
MAJOR	C				C				C			
MINOR	C _m				C _m				C _m			
7th	C ₇				C ₇				C ₇			

ENDING 2	1st. measure				2nd. measure				3rd. measure			
MAJOR	C				C				C			
MINOR	C _m				C _m				C _m			
7th	C ₇				C ₇				C ₇			

ENDING 3	1st. measure				2nd. measure				3rd. measure				4th. measure				5th. measure			
MAJOR	G ₆				F ₇				C ₆				G ₇				C	}	+	

* Minor or 7th chords produce the same progression as major chords.

STYLE: 10 8 BEAT

INTRO PATTERN

INTRO 1	1st. measure			2nd. measure		
MAJOR	C			C		G7
MINOR	C _m			C _m		G7

* 7th chords produce the same progression as major chords.

INTRO 2	1st. measure		2nd. measure		3rd. measure		4th. measure	
MAJOR	G _{sus4}		C		G _{sus4}		C	
MINOR	C _m		C _m		C _m		C _m	
7th	G _m		C7		G _m		C7	

INTRO 3	1st. measure		2nd. measure		3rd. measure		4th. measure	
MAJOR	Rhythm only		C		C		G _{7sus4}	
MINOR	C _m		C _m B ^b		A ^b _{M7}	C _m G	F _{m7}	G7

* 7th chords produce the same progression as major chords.

SOLO PATTERN

MAJOR	1st. measure		2nd. measure		3rd. measure		4th. measure		5th. measure		6th. measure		7th. measure		8th. measure	
VERSE 1	C				C		C		C		A _{m7}		F		F	F/G
VERSE 2	C		C		F		F		G		G		C		D _{m7} C	F G
CHORUS 1	A _m	E _m	F	C E	F G C		D _{m7} G7 C		A _m	E _m	F	C E	F G C		D _{m7} G7 C	
CHORUS 2	A _m	E _m	F	C E	F G C		D _m G7 C		C		F C		C _{M7}		F C	

* Minor or 7th chords produce the same progression as major chords.

ENDING PATTERN

ENDING 1	1st. measure				2nd. measure				3rd. measure				4th. measure				5th. measure			
MAJOR	C				C				C				C							
MINOR	C _m				C _m				C _m				C _m							

* 7th chords produce the same progression as major chords.

ENDING 2	1st. measure				2nd. measure				3rd. measure				4th. measure			
MAJOR	G _{sus4}		C		C		G ₇		C							
MINOR	G _m				C _m		G ₇		C _m							

* 7th chords produce the same progression as major chords.

ENDING 3	1st. measure				2nd. measure				3rd. measure				4th. measure				5th. measure				6th. measure			
MAJOR	C				C				G ₇				G ₇				C							
MINOR	C _m				C _m		B ^b		A ^b _{M7}		C _m	G	F _{m7}		G ₇		C _m							

* 7th chords produce the same progression as major chords.

STYLE: 11 POP ROCK

INTRO PATTERN

INTRO 1	1st. measure			
MAJOR	Rhythm only			

* Minor or 7th chords produce the same progression as major chords.

INTRO 2	1st. measure		2nd. measure		3rd. measure		4th. measure	
MAJOR	Rhythm only				C		C	
MINOR	Rhythm only				C _m		C _m	
7th	Rhythm only				C ₇		C ₇	

INTRO 3	1st. measure		2nd. measure		3rd. measure		4th. measure	
MAJOR	C		C		C		C	
MINOR	C _{m7}		C _{m7}		C _{m7}		C _{m7}	
7th	C ₇		C ₇		C ₇		C ₇	

SOLO PATTERN

MAJOR	1st. measure		2nd. measure		3rd. measure		4th. measure		5th. measure		6th. measure		7th. measure		8th. measure	
VERSE 1	C		C		C _{m7}		C _{m7}		F _m		F _m		D _{m7}		G ₇	
VERSE 2	C		C		C _{m7}		C _{m7}		F _{m7} ⁽⁹⁾		F _{m7} ⁽⁹⁾		D _{m7}		G ₇	
CHORUS 1	F _m		$\begin{matrix} \text{G}_m \\ \text{F} \end{matrix}$		F_m		$\begin{matrix} \text{G}_m \\ \text{F} \end{matrix}$		E_m		A_7		A^b		A^b G	
CHORUS 2	F _m		$\begin{matrix} \text{G}_m \\ \text{F} \end{matrix}$		F _m		$\begin{matrix} \text{G}_m \\ \text{F} \end{matrix}$		E _m		A ⁻		A ^b		G	

* Minor or 7th chords produce the same progression as major chords.

ENDING PATTERN

ENDING 1	1st. measure			2nd. measure		
MAJOR	C ₇			F		$\begin{matrix} \text{♪} \\ \text{C} \end{matrix}$
MINOR	C _{m7}	$\text{♪} \text{Gm7}$	A ^b	G _{m7}	A ^b B ^b	C _m
7th	C ₇			F _{sus4}		C ₇

ENDING 2	1st. measure			2nd. measure			3rd. measure			4th. measure			
MAJOR	C			$\begin{matrix} \text{C} \\ \text{E} \end{matrix}$			$\text{♪} \text{F}_6$			$\text{♪} \text{G}_7$	$\text{♪} \text{C}$		
MINOR	C _m			$\text{♪} \text{E}^b$			F _{m6}	G ₇		$\text{♪} \text{C}_m$			

* 7th chords produce the same progression as major chords.

ENDING 3	1st. measure			2nd. measure			3rd. measure			4th. measure			
MAJOR	C			C			$\text{♪} \text{F}$	$\text{♪} \text{C}$		C			
MINOR	C _m			$\text{♪} \text{E}^b$			$\text{♪} \text{B}^b$	$\frac{\text{G}_7}{\text{B}}$	$\text{♪} \text{C}_m$		C _m		
7th	C			C			F ₆	C		C			

STYLE: 12 BOUNCE ROCK

INTRO PATTERN

INTRO 1	1st. measure				2nd. measure			
MAJOR	C				C			
MINOR	C _m				C _m			
7th	C ₇				C ₇			

INTRO 2	1st. measure				2nd. measure				3rd. measure				4th. measure			
MAJOR	C				C				C				C			
MINOR	C _m				C _m				C _m				C _m			

* 7th chords produce the same progression as major chords.

INTRO 3	1st. measure				2nd. measure				3rd. measure				4th. measure				5th. measure				6th. measure				7th. measure				8th. measure			
MAJOR	C				$\frac{Gm7}{C}$				C				$\frac{Gm7}{C}$				C				$\frac{Gm7}{C}$				C				$\frac{Gm7}{C}$			

* Minor 7th chords produce the same progression as major chords.

SOLO PATTERN

MAJOR	1st. measure				2nd. measure				3rd. measure				4th. measure				5th. measure				6th. measure				7th. measure				8th. measure			
VERSE 1	C				C				C				C ₇				C				C				C ₇				C ₇			
VERSE 2	C				C				C				C ₇				C				C				C ₇				C ₇			
CHORUS 1	C				$\frac{G}{C}$				$\frac{F}{C}$				C				C				$\frac{G}{C}$				$\frac{F}{C}$				C			
CHORUS 2	C																C															

* Minor or 7th chords produce the same progression as major chords.

ENDING PATTERN

ENDING 1	1st. measure			2nd. measure			
MAJOR	C			$\frac{C}{E}$	F	G	C
MINOR	C _m			G ₇		C _m	

* 7th chords produce the same progression as major chords.

ENDING 2	1st. measure			2nd. measure			3rd. measure			4th. measure		
MAJOR	C			$\frac{G}{C}$			$\frac{F}{C}$			C		
MINOR	C _m			C _m			C _m			C _m		

* 7th chords produce the same progression as major chords.

ENDING 3	1st. measure			2nd. measure			3rd. measure			4th. measure			5th. measure		
MAJOR	C			B ^b			F			G		C			┐
MINOR	C _m	$\text{♪ } A^b$		B ^b	$\text{♪ } F_7$		A ^b M ₇			C _m					┐

* 7th chords produce the same progression as major chords.

STYLE: 13 FOLK ROCK

INTRO PATTERN

INTRO 1	1st. measure			
MAJOR	Rhythm only			

* Minor or 7th chords produce the same progression as major chords.

INTRO 2	1st. measure			2nd. measure		
MAJOR	C			C		
MINOR	C _m			C _m		
7th	C ₇			C ₇		

INTRO 3	1st. measure			2nd. measure			3rd. measure			4th. measure		
MAJOR	C			C			D _m			G		
MINOR	C _m			D _m	G ₇		C _m			G ₇		G ₇

* 7th chords produce the same progression as major chords.

SOLO PATTERN

MAJOR	1st. measure			2nd. measure			3rd. measure			4th. measure			5th. measure			6th. measure			7th. measure			8th. measure		
VERSE 1	C			G			D _m			G			E _m			A _m			D _m			G ₇		
VERSE 2	C			C			B			E			A _m			D _m			G			G		
CHORUS 1	C			C			G			G			D _m			D _m			G			G		
CHORUS 2	C		E _m B	A _m		A _m G	F			F _m			C			B ₇			G			G		

* Minor or 7th chords produce the same progression as major chords.

ENDING PATTERN

ENDING 1	1st. measure			2nd. measure		
MAJOR	C		D _m C	C		
MINOR	C _m	$\frac{F_m}{C}$	C _m C _m			
7th	C ₇		$\frac{B^b}{D}$ C ₇	C ₇		

ENDING 2	1st. measure			2nd. measure		3rd. measure			4th. measure		
MAJOR	C		D _{m7}	G _{sus4}	G ₇	C			C		
MINOR	C _m	$\frac{C_m}{B}$	$\frac{C_m7}{B^b}$	A _{m7} ⁽⁻⁵⁾		A ^b	G ₇		C _m		
7th	C ₇	$\frac{B^b}{D}$	G _{m7}			C ₇			C ₇		

ENDING 3	1st. measure			2nd. measure			3rd. measure			4th. measure		
MAJOR	C		$\text{♪ } B^b$				C		$\text{♪ } B^b$		$\text{♪ } C$	
MINOR	C _m		$\text{♪ } B^b$				C _m		$\text{♪ } B^b$		C _m	

* 7th chords produce the same progression as major chords.

STYLE: 14 ROCK BALLAD

INTRO PATTERN

INTRO 1	1st. measure			2nd. measure		
MAJOR	C			Em	G7	
MINOR	Cm		B ^b	A ^b M7	Fm	
7th	F	B ^b		C	B ^b	C7

INTRO 2	1st. measure			2nd. measure			3rd. measure			4th. measure			
MAJOR	C			C			C			C		$\frac{Dm}{F}$	G7
MINOR	Cm7			Cm7			Cm7			Cm7		Fm	

* 7th chords produce the same progression as major chords.

INTRO 3	1st. measure			2nd. measure			3rd. measure			4th. measure		
MAJOR	$\frac{F}{C}$		$\frac{Em7}{Dm7}$	C	$\frac{G}{B}$	$\frac{Am}{C7}$	F		G7	C		$\frac{Dm7}{G}$

* Minor or 7th chords produce the same progression as major chords.

SOLO PATTERN

MAJOR	1st. measure			2nd. measure			3rd. measure			4th. measure			5th. measure			6th. measure			7th. measure			8th. measure				
VERSE 1	C			C			C			C			C			C			C			C				
VERSE 2	C			C			C			C			C			C			C			C				
CHORUS 1	C			F		$\frac{Em}{Dm}$	$\frac{Dm7}{G}$			F		$\frac{Em}{Dm7}$	C			F		$\frac{Em}{Dm}$	$\frac{Dm7}{G}$			F		$\frac{Em}{Dm7}$	C	$\frac{Dm7}{G}$
CHORUS 2	C			E7			Am			C7			F			B ^b ₇ ⁽⁹⁾			Am7			$\frac{Am7}{G}$	F [#] _{m7} ⁽⁻⁵⁾		B ^b ₇ ⁽⁹⁾	

* Minor or 7th chords produce the same progression as major chords.

ENDING PATTERN

ENDING 1	1st. measure				2nd. measure				3rd. measure				
MAJOR	C				E _{m7}		F G			C			
MINOR	C _m		B ^b C		A ^b M7 C		Gm7 C			C _m			
7th	C7			B ^b 7	A _m G7		C						

ENDING 2	1st. measure				2nd. measure				3rd. measure				4th. measure				
MAJOR	C			C7 E	F			E _m	D _m		G7			F	E _m D _m	C	
MINOR	C _m		C _m M7		C _m 7		C _m 6		F _m 7		D _m ⁽⁻⁹⁾	G7		C _m			
7th	C			C7 E	F			E _m	D _m 7		G7			F	E _m D _m	C	

ENDING 3	1st. measure				2nd. measure				3rd. measure				4th. measure				5th. measure				6th. measure				7th. measure				8th. measure				
MAJOR	C		C7 B ^b		F A		F _m A ^b		C G		G7		C		C7 E	F	E _m	D _m 7		C	G B	A _m 7	C7 E	F		G7		C					
MINOR	C _m		B ^b C		A ^b C				C _m		B ^b C		C _m		B ^b C					C _m		B ^b C		C _m							C _m		

* 7th chords produce the same progression as major chords.

STYLE: 15 PIANO BALLAD

INTRO PATTERN

INTRO 1	1st. measure				2nd. measure			
MAJOR	C	C ₇	$\frac{F}{C}$		$\frac{F}{C}$	C	GC	
MINOR	C _m				$\frac{B^b}{C}$		C_m	
7th	C				$\frac{B^b}{C}$		C_7	

INTRO 2	1st. measure			2nd. measure			3rd. measure			4th. measure		
MAJOR	C		$\frac{G_m}{C}$	$\frac{F}{C}$		$\frac{F_m}{C}$	C		$\frac{G_m}{C}$	$\frac{F}{C}$		$\frac{F_m}{C}$
7th	C		$\frac{G_m}{C}$	$\frac{F}{C}$		$\frac{F_m}{C}$	C		A _m	G _{m7}		C ₇

* Minor chords produce the same progression as major chords.

INTRO 3	1st. measure			2nd. measure			3rd. measure			4th. measure		
MAJOR	C			A _{m7}			F			D ^b ₇		

* Minor or 7th chords produce the same progression as major chords.

SOLO PATTERN

MAJOR	1st. measure			2nd. measure			3rd. measure			4th. measure			5th. measure			6th. measure			7th. measure			8th. measure			
VERSE 1	C			F			C			F			C			F			C			F			
VERSE 2	C			A _m			F			C	G		C			A _m			F			C		G	
CHORUS 1	C			G			B ^b			F			A ^b			B ^b			$\frac{B^b}{C}$			C			
CHORUS 2	C		F _m	B ^b		E ^b	A ^b		$\frac{D_7}{A}$	G		G _{sus4}	G	C _m	F _m	B ^b		E ^b	A ^b		$\frac{D_7}{A}$	G		G _{sus4}	G

* Minor or 7th chords produce the same progression as major chords.

ENDING PATTERN

ENDING 1	1st. measure			2nd. measure		
MAJOR	C	C ₇	$\frac{F}{C}$	$\frac{F}{C}$	GC	
MINOR	C _{m7}			C _{m7}	C _m	
7th	C ₇			C ₇	GC ₇	

ENDING 2	1st. measure		2nd. measure		3rd. measure		4th. measure	
MAJOR	B _{m7} ⁽⁻⁵⁾	E ₇	A _{m7}	D ₇	$\frac{C}{G}$	G ₇	C	$\frac{F}{C}$
MINOR	F _{m7}	B ^b ₇	$\frac{G_7}{B}$	C _m	F _m	F [#] _{dim}	$\frac{C_m}{G}$	G ₇

* 7th chords produce the same progression as major chords.

ENDING 3	1st. measure		2nd. measure		3rd. measure		4th. measure		5th. measure		6th. measure		7th. measure		8th. measure	
MAJOR	C	F _m	B ^b	E ^b	A ^b	$\frac{D_7}{A}$	G ₇		C _m	F _m	B ^b	E ^b	A ^b	F _m	$\frac{C_m}{G}$	G ₇

* Minor or 7th chords produce the same progression as major chords.

STYLE: 20 SLOW ROCK

INTRO PATTERN

INTRO 1	1st. measure			2nd. measure		
MAJOR	C			C		
MINOR	C _m			C _m		
7th	C ₇			C ₇		

INTRO 2	1st. measure			2nd. measure			3rd. measure			4th. measure		
MAJOR	C		A _{m7}	F ₆		G _{sus4} G	C		A _{m7}	F ₆		G _{sus4} G
MINOR	C _{m7} ⁽⁹⁾			C _{m6} ⁽⁹⁾			A _{m7} ^P C			G _{sus4} C		G
7th	C ₇			F C			F _m C			C ₇ ⁽⁹⁾		

INTRO 3	1st. measure			2nd. measure			3rd. measure			4th. measure		
MAJOR	C		A _m	F		G	C		A _m	A _{b7}		G _{sus4} G ₇
7th	C		A _m	F		G	C		A _m	G _{m7}		C _{7sus4} C ₇

* Minor chords produce the same progression as major chords.

SOLO PATTERN

MAJOR	1st. measure				2nd. measure				3rd. measure				4th. measure				5th. measure				6th. measure				7th. measure				8th. measure			
VERSE 1	C				A _m				F				G				C				A _m				F				G			
VERSE 2	C				A _m				F				G				C				A _m				F				G			
CHORUS 1	C _m	B _b D	E _b	F	C _m	F	C _m	G _{m7}	C _m	B _b D	E _b	F	G _{sus4}	G		C _m	B _b D	E _b	F	C _m	F	C _m	G _{m7}	A _b	G _{m7}	A _b	B _b	C _m	F	C _m	G _{7sus4}	
CHORUS 2	C _m add9				E _b add9 C				B _b add9 C				C _m add9			E _b add9				F#add9 E _b				D _b add9 E _b				E _b add9				

STYLE: 20 SLOW ROCK

MINOR	1st. measure			2nd. measure			3rd. measure			4th. measure		5th. measure			6th. measure			7th. measure		8th. measure										
VERSE 1	C _m	E ^b		F	A ^b		C _m	E ^b		G _{7sus4}	G	C _m	E ^b		F	A ^b		C _m	G		C _m									
VERSE 2	C _m	E ^b		F	A ^b		C _m	E ^b		G _{7sus4}	G	C _m	E ^b		F	A ^b		C _m	G		C _m									
CHORUS 1	C _m	$\frac{B^b}{D}$	E ^b	F	C _m	F	C _m	G _m	C _m	$\frac{B^b}{D}$	E ^b	F	G _{sus4}	G	C _m	$\frac{B^b}{D}$	E ^b	F	C _m	F	C _m	G _m	A ^b	G _{m7}	A ^b	B ^b	C _m	F	G _m	G ₇
CHORUS 2	C _{madd9}			$\frac{E^b_{add9}}{C}$					$\frac{B^b_{add9}}{C}$				C _{madd9}		$\frac{E^b_{add9}}{C}$			$\frac{F^{\#}_{add9}}{E^b}$					$\frac{D^b_{add9}}{E^b}$			$\frac{E^b_{add9}}{C}$				

* 7th chords produce the same progression as major chords.

ENDING PATTERN

ENDING 1	1st. measure			2nd. measure		
MAJOR	C			C		
MINOR	C _m			C _m		
7th	C ₇			C ₇		

ENDING 2	1st. measure			2nd. measure		
MAJOR	C			C	D ^{b7}	C ₆
MINOR	C _m			C _m	D ^{b7}	C _{m7}
7th	C ₇			C ₇	D ^{b7}	C ₇

ENDING 3	1st. measure			2nd. measure			3rd. measure			4th. measure		
MAJOR	C	A _m		F	G ₇		E _m	A		F	G ₇	C
MINOR	C _m	E ^b		F	A ^b		$\frac{C_m}{G}$	G _{sus4}	G ₇	C _m	F _m	C _m

* 7th chords produce the same progression as major chords.

STYLE: 21 SOUL ROCK

INTRO PATTERN

INTRO 1	1st. measure			2nd. measure		
MAJOR	C			C		
MINOR	C _m			C _m		
7th	C ₇			C ₇		

INTRO 2	1st. measure			2nd. measure			3rd. measure			4th. measure		
MAJOR	C _{sus4}			C			C _{sus4}			C ₇		
MINOR	C _m ⁽¹¹⁾			C _m			C _m ⁽⁹⁾			C _m ⁽¹¹⁾		

* 7th chords produce the same progression as major chords.

INTRO 3	1st. measure			2nd. measure			3rd. measure			4th. measure			5th. measure			6th. measure			7th. measure			8th. measure		
MAJOR	C			E ₇			F			D ₇	G ₇	C			E ₇			F			D ₇	D _{m7} G		

* Minor or 7th chords produce the same progression as major chords.

SOLO PATTERN

MAJOR	1st. measure			2nd. measure			3rd. measure			4th. measure			5th. measure			6th. measure			7th. measure			8th. measure		
VERSE 1	C			C			C			C			C			C			C			C		
VERSE 2	C			C			C			C			C			C			C			C		
CHORUS 1	C			E ₇			F			D ₇	F G	C			E ₇			F			D ₇	F G		
CHORUS 2	C			E ₇			F			D	G _{sus4}	C			E ₇			F			D	G _{sus4}		



* Minor or 7th chords produce the same progression as major chords.

ENDING PATTERN

ENDING 1	1st. measure			2nd. measure			3rd. measure			
MAJOR	C			C				C		
MINOR	C _m			C _{m7}			C _m			
7th	C ₇			C ₇			C ₇			

ENDING 2	1st. measure			2nd. measure			3rd. measure			4th. measure			5th. measure			
MAJOR	C			C ₇			C ₇			C		B ^b	$\frac{F}{A}$	C		

* Minor or 7th chords produce the same progression as major chords.

ENDING 3	1st. measure			2nd. measure			3rd. measure			4th. measure			5th. measure			6th. measure			7th. measure			8th. measure						
MAJOR	C				E ₇		F				D ₇		$\frac{F}{G}$	$\frac{C}{G}$	C				E ₇			F			D ₇		$\frac{Dm7}{G}$	C

* Minor or 7th chords produce the same progression as major chords.

STYLE: 22 SHUFFLE

INTRO PATTERN

INTRO 1	1st. measure		2nd. measure	
MAJOR		Rhythm only		C
MINOR		Rhythm only		C _m
7th		Rhythm only		C ₇

INTRO 2	1st. measure		2nd. measure		3rd. measure		4th. measure	
MAJOR	C		C _{add9}	G	A _{m7}	F ₆	C	$\frac{F_{add9}}{B^b}$
MINOR	C _{m7}		C _{m7}		A ^b _{M7}		F _{m7}	$\frac{D_{m7}}{G}$

* 7th chords produce the same progression as major chords.

INTRO 3	1st. measure		2nd. measure		3rd. measure		4th. measure	
MAJOR	C		C		C		C	
MINOR	Rhythm only		C _{m7}		C _{m7}		C _{m7}	
7th	Rhythm only		C ₇		C ₇		C ₇	

SOLO PATTERN

MAJOR	1st. measure		2nd. measure		3rd. measure		4th. measure		5th. measure		6th. measure		7th. measure		8th. measure	
VERSE 1	G _{m7} ⁽⁹⁾		C _{add9}		$\frac{C_{m7}}{F}$		C _{add9}		$\frac{A^b_{M7}}{B^b}$		C _{add9}		$\frac{C_{m7}}{F}$		$\frac{D_{m7}}{G}$	
VERSE 2	C _{m7}			B ^b	A ^b _{M7} ⁽⁹⁾		G _{m7}		F _{m7} ⁽⁹⁾				D _{m7}		$\frac{D_{m7}}{G}$ ⁽¹¹⁾	
CHORUS 1	C ₇ ⁽⁹⁾		C ₇ ⁽⁹⁾		C ₇ ⁽⁹⁾		C ₇ ⁽⁹⁾		C ₇ ⁽⁹⁾		C ₇ ⁽⁹⁾		C ₇ ⁽⁹⁾		G ₇	
CHORUS 2	C		G		C		F ₇	G ₇	C		G		C		G ₇	

STYLE: 22 SHUFFLE

MINOR	1st. measure	2nd. measure	3rd. measure	4th. measure	5th. measure	6th. measure	7th. measure	8th. measure
VERSE 1	Gm7 ⁽⁹⁾	Cadd9	$\frac{Cm7}{F}$	Cadd9	$\frac{A^b M7^{(9)}}{B^b}$	Cadd9	$\frac{Cm7}{F}$	G7sus4
VERSE 2	Cm7	B ^b	A ^b M7	Gm7	Fm7 ⁽⁹⁾		Dm7	G7
CHORUS 1	Cm7	Cm7	Cm7	Cm7	Cm7	Cm7	Cm7	Cm7
CHORUS 2	C	G	C	F7 ⁽¹³⁾ G7	C	G	C	G7

* 7th chords produce the same progression as major chords.

ENDING PATTERN

ENDING 1	1st. measure	2nd. measure	3rd. measure	4th. measure	5th. measure	6th. measure
MAJOR	C $\frac{G}{C}$ $\frac{F}{C}$	C $\frac{G}{E}$ Am	Dm7 $\frac{F}{G}$			
MINOR	Cm $\frac{B^b}{C}$	Cm $\frac{B^b}{C}$	A ^b M7 $\frac{B^b}{A^b}$	Fm7 Gm7	Cm7	

* 7th chords produce the same progression as major chords.

ENDING 2	1st. measure	2nd. measure	3rd. measure	4th. measure
MAJOR	C	C	C	C GC
MINOR	Cm	Cm	Cm	Cm GmCm
7th	C7	C7	C7	C7

ENDING 3	1st. measure	2nd. measure	3rd. measure	4th. measure
MAJOR	C	G	C	G7 $\frac{F}{A}$ B ^b C
MINOR	Cm	Cm	Cm	Cm

* 7th chords produce the same progression as major chords.



STYLE: 23 FUNK

INTRO PATTERN

INTRO 1	1st. measure	2nd. measure
MAJOR	Rhythm only	C
MINOR	Rhythm only	C _m
7th	Rhythm only	C

INTRO 2	1st. measure	2nd. measure	3rd. measure	4th. measure
MAJOR	C	C	C	C
MINOR	C _m ⁽⁹⁾	B ^b (9) C	C _m ⁽⁹⁾	B ^b (9) C
7th	C ₇	C ₇	C ₇	C ₇

INTRO 3	1st. measure	2nd. measure	3rd. measure	4th. measure	5th. measure	6th. measure	7th. measure	8th. measure
MAJOR	F _{m7} ⁽¹¹⁾	G _{m7} ⁽¹¹⁾	C _{m7} ⁽¹¹⁾	C _{m7} ⁽¹¹⁾	F _{m7} ⁽¹¹⁾	G _{m7} ⁽¹¹⁾	C _{m7} ⁽¹¹⁾	C _{m7} ⁽¹¹⁾

* Minor or 7th chords produce the same progression as major chords.

SOLO PATTERN

MAJOR	1st. measure	2nd. measure	3rd. measure	4th. measure	5th. measure	6th. measure	7th. measure	8th. measure
VERSE 1	C ₇ ⁽⁺⁹⁾	C ₇ ⁽⁺⁹⁾	C ₇ ⁽⁺⁹⁾	C ₇ ⁽⁺⁹⁾	C ₇ ⁽⁺⁹⁾	C ₇ ⁽⁺⁹⁾	C ₇ ⁽⁺⁹⁾	C ₇ ⁽⁺⁹⁾
VERSE 2	C ₇ ⁽⁺⁹⁾	C ₇ ⁽⁺⁹⁾	C ₇ ⁽⁺⁹⁾	C ₇ ⁽⁺⁹⁾	C ₇ ⁽⁺⁹⁾	C ₇ ⁽⁺⁹⁾	C ₇ ⁽⁺⁹⁾	C ₇ ⁽⁺⁹⁾
CHORUS 1	C ₇	C ₇	F ₇ ⁽⁹⁾	F ₇ ⁽⁹⁾	C ₇	C ₇	F ₇ ⁽⁹⁾	F ₇ ⁽⁹⁾
CHORUS 2	C ₇	C ₇	F ₇ ⁽⁹⁾	F ₇ ⁽⁹⁾	C ₇	C ₇	F ₇ ⁽⁹⁾	F ₇ ⁽⁹⁾

* Minor or 7th chords produce the same progression as major chords.

ENDING PATTERN

ENDING 1	1st. measure				2nd. measure			
MAJOR	C				C			C ⁽⁺⁹⁾
MINOR	C _m				C _m			C ₇ ⁽⁺⁹⁾
7th	C ₇				C ₇			C ₇ ⁽⁺⁹⁾

ENDING 2	1st. measure				2nd. measure				3rd. measure				4th. measure			
MAJOR	C				C				C				C			
MINOR	C _m				C _m				C _m				C _m			
7th	C ₇				C ₇				C ₇				C ₇			

ENDING 3	1st. measure				2nd. measure				3rd. measure				4th. measure				5th. measure				6th. measure				7th. measure				8th. measure			
MAJOR	F _{m7} ⁽¹¹⁾				G _{m7} ⁽¹¹⁾				C _{m7} ⁽¹¹⁾				C _{m7} ⁽¹¹⁾				F _{m7} ⁽¹¹⁾				G _{m7} ⁽¹¹⁾				C _{m7} ⁽¹¹⁾				C _{m7} ⁽¹¹⁾			

* Minor or 7th chords produce the same progression as major chords.

STYLE: 24 SWING

INTRO PATTERN

INTRO 1	1st. measure			2nd. measure		
MAJOR	C		C [#] _{dim}	D _{m7}		G ₇
MINOR	C _m			D ₇		G ₇
7th	C ₇			C ₇		

INTRO 2	1st. measure			2nd. measure		3rd. measure		4th. measure	
MAJOR	C		A ₇ C [#]	D _{m7}	G ₇	E _{m7}	E ^b ₇	D _{m7}	G ₇
MINOR	C _m		C _m M ₇	C _{m7}	C _{m6}	A ^b ₇	G ₇	 C _m	
7th	C ₇			C ₇		C ₇		C ₇	

INTRO 3	1st. measure		2nd. measure		3rd. measure		4th. measure	
MAJOR	C G	C _{dim} G	D _{m7} G	C _{dim} G	C		C	G ₇
MINOR	C _m		A ^b ₇		F _{m7}		D ₇  G ₇	
7th	B ^b _{M7} C		B ^b _{M7} C		C ₇		C ₇	

SOLO PATTERN

MAJOR	1st. measure			2nd. measure		3rd. measure		4th. measure		5th. measure		6th. measure		7th. measure		8th. measure	
VERSE 1	C ₇			F ₇		C ₇		F ₇		C ₇		B ^b ₇	A ₇	D ₇	G ₇	C	
VERSE 2	C			G ₇		G ₇		C		C	C ₇	F		C G	G ₇	C	
CHORUS 1	C					F ₇				D ₇				G ₇			
CHORUS 2	F _{m7}	B ^b ₇		E ^b _{M7}	A ^b _{M7}	D _{m7} ⁽⁻⁵⁾	G ₇	C _m		A ^b _{m7}	D ^b ₇	F [#] _{M7}	B _{M7}	F _{m7} ⁽⁻⁵⁾	B ^b ₇ ⁽⁻⁹⁾	E ^b	

MINOR	1st. measure			2nd. measure			3rd. measure			4th. measure			5th. measure			6th. measure			7th. measure			8th. measure					
VERSE 1	C _{m7}			F ₇			C _{m7}			F ₇			C _{m7}			F ₇			A ^{b(9)} ₇			G ⁽⁻¹³⁾ ₇			C _m		
VERSE 2	C _{m7}			F ₇			C _{m7}			F ₇			C _{m7}			F ₇			C _{m7}						F ₇		
CHORUS 1	C _{m7}			D _{m7} ⁽⁻⁵⁾		G ₇ ⁽⁻⁹⁾	C _{m7}			F _{m7}		B ^b ₇	A _{m7} ⁽⁻⁵⁾		A ^b ₇	G _{m7}		C ₇	F ₇			B ^b ₇			E ^b ₆		G ₇
CHORUS 2	F _{m7}		B ^b ₇	E ^b _{M7}		A ^b _{M7}	D _{m7} ⁽⁻⁵⁾		G ₇ ⁽⁻⁹⁾	C _m			A ^b _{m7}		D ^b	F [#] _{M7}		B _{M7}	F _{m7} ⁽⁻⁵⁾			B ^b ₇ ⁽⁻⁹⁾			E ^b ₆		

* 7th chords produce the same progression as major chords.

ENDING PATTERN

ENDING 1	1st. measure			2nd. measure		
MAJOR	C			F	G ₇	C ₆
MINOR	C _m			G ₇	C _m	

* 7th chords produce the same progression as major chords.

ENDING 2	1st. measure			2nd. measure			3rd. measure			4th. measure				
MAJOR	C		A ₇	D _{m7}		G ₇	C ₇	C ₇ E	F	F [#] _{dim}	G ₇		C	
MINOR	A ^b	G _{m7}	F _{m7}	F _{m7}	G _{m7}	A ^b	B ^b	C _m				G _m	G ₇	C _m

* 7th chords produce the same progression as major chords.

ENDING 3	1st. measure			2nd. measure			3rd. measure			4th. measure		
MAJOR	A ^b	G _{m7}	F _{m7}	F _{m7}	D ^b E ^b	D ^b ₇	Rhythm only			C ₆		

* Minor or 7th chords produce the same progression as major chords.

STYLE: 25 BIG BAND

INTRO PATTERN

INTRO 1	1st. measure				2nd. measure				3rd. measure				4th. measure			
MAJOR	C				C				C				C			
MINOR	C _m				C _m				C _m				C _m			
7th	C ₇				C ₇				C ₇				C ₇			

INTRO 2	1st. measure				2nd. measure				3rd. measure				4th. measure			
MAJOR	C				C				C				C			
MINOR	C _m				C _m				C _m				C _m			
7th	C ₇				C ₇				C ₇				C ₇			

INTRO 3	1st. measure				2nd. measure				3rd. measure				4th. measure			
MAJOR	$\frac{D_{m7}^{(9)}}{C}$				G ₇ ⁽⁹⁾				C _{M7} ⁽⁹⁾				G ₇ ⁽⁻¹³⁾			

* Minor or 7th chords produce the same progression as major chords.

SOLO PATTERN

MAJOR	1st. measure				2nd. measure				3rd. measure				4th. measure				5th. measure				6th. measure				7th. measure				8th. measure											
VERSE 1	C ₆				C [#] _{dim}				D _{m7} ⁽⁹⁾				G ₇ ^(13 9)				C ₆				A ^b ₉				D _{m7} ⁽⁹⁾				G ₇ ^(13 9)											
VERSE 2	C ₆				F				B ^b _{M7} ←				BREAK				→ C _{M7}				B ^b _{M7}				A _{m7} ⁽⁹⁾				A ^b ₇ ⁽⁹⁾ G ₇											
CHORUS 1	C				C [#] _{dim}				D _{m7}				D [#] _{dim}				E _{m7}				A ₇ ⁽⁹⁾				D _m				F ₆				D ^b ₇ ⁽⁹⁾				G ₇			
CHORUS 2	C ₆				A _{m7}				B ^b _{M7}				D ^b ₇				C ₆				E ^b ₇				D _{m7}				G ₇ ⁽⁹⁾											

* Minor or 7th chords produce the same progression as major chords.

ENDING PATTERN

ENDING 1	1st. measure				2nd. measure				3rd. measure				4th. measure			
MAJOR	C		E ^b ₇		D ₇		D ^b ₇		C _{M7}				C ₆			
MINOR	C _m		E ^b ₇		D _{m7} ⁽⁻⁵⁾		G ₇		C _m				C _m			

* 7th chords produce the same progression as major chords.

ENDING 2	1st. measure				2nd. measure				3rd. measure				4th. measure			
MAJOR	F _{M7}		G _{M7}		E _{m7}		A ₇		D _{m7}		D ^b ₇		C _{M7}			
	G		F													
MINOR	G _{m7}		F _{m7}		A ^b ₇				D _{m7} ⁽⁻⁵⁾		G ₇ ⁽⁻¹³⁾		C _{m7}			

* 7th chords produce the same progression as major chords.

ENDING 3	1st. measure				2nd. measure				3rd. measure				4th. measure				5th. measure				6th. measure				7th. measure				8th. measure			
MAJOR	D _{m7}				G ₇				E _{m7}				A ₇				D _{m7}		G ₇		G ₇				C				C _{M7}			

* Minor or 7th chords produce the same progression as major chords.

4 3 2 1
5 4 3 2
6 5 4 3
7 6 5 4
8 7 6 5
9 8 7 6
10 9 8 7
11 10 9 8
12 11 10 9
13 12 11 10
14 13 12 11
15 14 13 12
16 15 14 13
17 16 15 14
18 17 16 15
19 18 17 16
20 19 18 17
21 20 19 18
22 21 20 19
23 22 21 20
24 23 22 21
25 24 23 22
26 25 24 23
27 26 25 24
28 27 26 25
29 28 27 26
30 29 28 27
31 30 29 28
32 31 30 29
33 32 31 30
34 33 32 31
35 34 33 32
36 35 34 33
37 36 35 34
38 37 36 35
39 38 37 36
40 39 38 37
41 40 39 38
42 41 40 39
43 42 41 40
44 43 42 41
45 44 43 42
46 45 44 43
47 46 45 44
48 47 46 45
49 48 47 46
50 49 48 47
51 50 49 48
52 51 50 49
53 52 51 50
54 53 52 51
55 54 53 52
56 55 54 53
57 56 55 54
58 57 56 55
59 58 57 56
60 59 58 57
61 60 59 58
62 61 60 59
63 62 61 60
64 63 62 61
65 64 63 62
66 65 64 63
67 66 65 64
68 67 66 65
69 68 67 66
70 69 68 67
71 70 69 68
72 71 70 69
73 72 71 70
74 73 72 71
75 74 73 72
76 75 74 73
77 76 75 74
78 77 76 75
79 78 77 76
80 79 78 77
81 80 79 78
82 81 80 79
83 82 81 80
84 83 82 81
85 84 83 82
86 85 84 83
87 86 85 84
88 87 86 85
89 88 87 86
90 89 88 87
91 90 89 88
92 91 90 89
93 92 91 90
94 93 92 91
95 94 93 92
96 95 94 93
97 96 95 94
98 97 96 95
99 98 97 96
100 99 98 97

STYLE: 30 JAZZ BALLAD

INTRO PATTERN

INTRO 1	1st. measure		2nd. measure	
MAJOR		Rhythm only		C
MINOR		Rhythm only		C _m
7th		Rhythm only		C ₇

INTRO 2	1st. measure		2nd. measure	
MAJOR		Rhythm only	C _{sus4}	
MINOR		Rhythm only	C ₇ ⁽⁺⁵⁾	
7th		Rhythm only	C _{7sus4}	

INTRO 3	1st. measure		2nd. measure		3rd. measure		4th. measure		5th. measure		6th. measure		7th. measure		8th. measure			
MAJOR	C ₆ ⁽⁹⁾	A ₇ ^(-13/9)	D _{m7} ⁽⁹⁾	G ₇ ⁽⁹⁾	E _{m7} ⁽¹¹⁾	E ₇ ⁽¹¹⁾	A ₇ ^b	D _{m7} ⁽¹¹⁾	G ₇	C _{m7} ⁽¹¹⁾	A ₇ ^(13/9)	A ₇ ^b ^(13/9)	G ₇ ^(-13/9)	G ₇ ^b	F _{m7} ⁽⁹⁾	D ₇ ^b ⁽⁹⁾	D ₇ ⁽⁺⁹⁾	G ₇ ⁽⁻¹³⁾

* Minor or 7th chords produce the same progression as major chords.

SOLO PATTERN

MAJOR	1st. measure		2nd. measure		3rd. measure		4th. measure		5th. measure		6th. measure		7th. measure		8th. measure	
VERSE 1	C _{m7}	A _{m7}	D _{m7}	G ₇	E _{m7}	A ₇	D _{m7}	G ₇	C _{m7}	A _{m7}	D _{m7}	G ₇	E _m	E ₇ ^b	D _{m7}	G ₇
VERSE 2	C _{m7}	A _{m7}	D _{m7}	G ₇	E _{m7}	A ₇	D _{m7}	G ₇	C _{m7}	A _{m7}	D _{m7}	G ₇	E _m	E ₇ ^b	D _{m7}	G ₇
CHORUS 1	C ₇ ^(13/9)	A ₇ ⁽⁹⁾	A ₇ ^b ⁽¹³⁾	G ₇ ⁽⁻¹³⁾	G _{m7} ^(13/9)	E ₇ ^b ^(13/9)	A ₇ ^b ⁽⁹⁾	D ₇ ^b ⁽⁹⁾	C ₇ ^(13/9)	A ₇ ⁽⁹⁾	A ₇ ^b ⁽¹³⁾	G ₇ ⁽⁻¹³⁾	E _{m7} ⁽⁹⁾	E ₇ ^b ⁽⁹⁾	A ₇ ^b ⁽⁹⁾	D ₇ ^b ⁽⁹⁾
CHORUS 2	C ₆ ⁽⁹⁾	F ₇ ⁽¹³⁾	E _{m7}	A ₇ ^(-13/9)	D _{m7} ⁽⁹⁾		G ₇ ^(13/9)		C _{m7} ⁽⁹⁾	F ₇ ⁽¹³⁾	E _{m7} ^(11/9)	A ₇ ^(-13/9)	E ₇ ^b ⁽⁹⁾	A ₇ ^b ^(13/9)	D _{m7} ⁽⁹⁾	G ₇ ^(13/9)

STYLE: 30 JAZZ BALLAD

MINOR	1st. measure		2nd. measure		3rd. measure		4th. measure		5th. measure		6th. measure		7th. measure		8th. measure	
VERSE 1	Cm7	Am7	Dm7	G7	Em7	A7	Dm7	G7	Cm7	Am7	Dm7	G7	Em	E ^b 7	Dm7	G7
VERSE 2	Cm7 ⁽⁹⁾	A7 ^(13 9)	D7	G7 ^(-13 -9)	Cm7 ⁽⁹⁾	E ^b m7 A ^b 7 ^(13 9)	D7	G7 ^(-13 -9)	Cm7 ⁽⁹⁾	A7 ^(13 9)	D7	G7 ^(-13 -9)	D7 ⁽⁺⁹⁾		G7 ^(-13 -9)	
CHORUS 1	Cm7 ⁽⁹⁾		F7 ⁽⁹⁾		Cm7 ⁽⁹⁾		F7 ⁽⁹⁾		E ^b m7 ⁽⁹⁾		A ^b 7 ^(13 9)		Dm7 ⁽⁻⁵⁾		G7 ^(-13 -9)	
CHORUS 2	Cm7 ⁽⁹⁾		D7 ⁽⁺⁹⁾	G7 ^(-13 -9)	Cm7 ⁽⁹⁾		D7 ⁽⁺⁹⁾	G7 ^(-13 -9)	Fm7		B ^b 7 ^(13 9)		E ^b m7 ⁽⁹⁾	A ^b 7 ^(13 9)	D7 ⁽⁺⁹⁾	G7 ⁽⁻⁹⁾

7th	1st. measure		2nd. measure		3rd. measure		4th. measure		5th. measure		6th. measure		7th. measure		8th. measure	
VERSE 1	Cm7	Am7	Dm7	G7	Em7	A7	Dm7	G7	Cm7	Am7	Dm7	G7	Em	E ^b 7	Dm7	G7
VERSE 2	C7 ⁽⁹⁾		B ^b 7 ⁽⁹⁾		C7 ⁽⁹⁾		B ^b 7 ⁽⁹⁾		C7 ⁽⁹⁾		B ^b 7 ⁽⁹⁾		A ^b 7 ⁽⁹⁾		B ^b 7	D ^b 7 ⁽⁹⁾ B
CHORUS 1	C7		C7		C7		C7		C7		C7		C7		C7	
CHORUS 2	C7 ^(13 9)		C7 ^(13 9)		F7 ⁽⁹⁾		D7 ⁽⁺⁹⁾	G7	C7 ^(13 9)		C7 ^(13 9)		F7 ⁽⁹⁾		Fm7	G7

ENDING PATTERN

ENDING 1	1st. measure		2nd. measure	
MAJOR	Rhythm only		D ^b 7C	
MINOR	Rhythm only		G7 B Cm	
7th	Rhythm only		G7C7	

ENDING 2	1st. measure		2nd. measure	
MAJOR	C		C	
MINOR	Cm		Cm	
7th	C7		C7	

ENDING 3	1st. measure		2nd. measure	
MAJOR	C	Dm7 F	G7	C
MINOR	Cm		Dm7 ⁽⁻⁵⁾ G7	Cm
7th	C7	F A ^b 7 G ^b	G7	C7



STYLE: 31 BOOGIE

INTRO PATTERN

INTRO 1	1st. measure	2nd. measure
MAJOR	Rhythm only	C
MINOR	Rhythm only	C _m
7th	Rhythm only	C ₇

INTRO 2	1st. measure	2nd. measure	3rd. measure	4th. measure
MAJOR		Rhythm only	C	C
MINOR		Rhythm only	C _m	C _m

* 7th chords produce the same progression as major chords.

INTRO 3	1st. measure	2nd. measure	3rd. measure	4th. measure
MAJOR	C	C	C	C
MINOR	C _m	C _m	C _m	C _m
7th	C ₇	C ₇	C ₇	C ₇

SOLO PATTERN

MAJOR	1st. measure	2nd. measure	3rd. measure	4th. measure	5th. measure	6th. measure	7th. measure	8th. measure
VERSE 1	C	C	C	C	C	C	C	C
VERSE 2	F ₇	F ₇	C	C	G	F	C	C
CHORUS 1	C	C	C	C	F	F	C	C
CHORUS 2	G	F	C	C	G	F	C	C

* Minor or 7th chords produce the same progression as major chords.

ENDING PATTERN

ENDING 1	1st. measure				2nd. measure				3rd. measure				4th. measure			
MAJOR	C				C				C				C			
MINOR	C _m				C _m				C _m				C _m			
7th	C ₇				C ₇				C ₇				C ₇			

ENDING 2	1st. measure				2nd. measure				3rd. measure				4th. measure			
MAJOR	C				C				G ₇				G ₇	♪	C	
MINOR	C _m				C _m				C _m				G ₇	♪	C _m	
7th	C ₇				C ₇				G ₇				G ₇	♪	C ₇	

ENDING 3	1st. measure				2nd. measure				3rd. measure				4th. measure			
MAJOR	C				C				G ₇				G ₇	♪	C	
MINOR	C _m				C _m				C _m				C _m			
7th	C ₇				C ₇				G ₇				G ₇	♪	C ₇	



STYLE: 32 DIXIE

INTRO PATTERN

INTRO 1	1st. measure	2nd. measure
MAJOR	Rhythm only	C
MINOR	Rhythm only	C _m
7th	Rhythm only	C ₇

INTRO 2	1st. measure	2nd. measure	3rd. measure	4th. measure
MAJOR	C	C	C	C G C
MINOR	C _m	C _m	C _m	C _m G C _m
7th	C ₇	C ₇	C ₇	C ₇ G C ₇

INTRO 3	1st. measure	2nd. measure	3rd. measure	4th. measure
MAJOR	C	C	G ₇	G ₇
MINOR	C _m	C _m	G ₇	G ₇
7th	C ₇	C ₇	C ₇	C ₇

SOLO PATTERN

MAJOR	1st. measure	2nd. measure	3rd. measure	4th. measure	5th. measure	6th. measure	7th. measure	8th. measure
VERSE 1	C	G ₇	C	G ₇	C	G ₇	C	G ₇
VERSE 2	C	F	G ₇	C	G C	F	G ₇	C G C
CHORUS 1	C	D _m	C	G	C	D _m	C	G
CHORUS 2	C	$\frac{C_7}{B^b}$	A _m	C	$\frac{C_7}{B^b}$	F G	C	$\frac{C_7}{B^b}$ F G

* Minor or 7th chords produce the same progression as major chords.

ENDING PATTERN

ENDING 1	1st. measure			2nd. measure		
MAJOR	C			C	G7	C
MINOR	C _m			C _m	G7	C
7th	C7			C7	G _m 7	C7

ENDING 2	1st. measure			2nd. measure			3rd. measure			4th. measure		
MAJOR	C			C			G7			G7		C
MINOR	C _m			C _m			G7			G7		C _m
7th	C7			C7			G _m 7			G _m 7		C

ENDING 3	1st. measure			2nd. measure			3rd. measure			4th. measure		
MAJOR	C			F			G7			C	G7	C
MINOR	C _m			F _m			G7			C _m	G7	C _m

* 7th chords produce the same progression as major chords.

STYLE: 33 WALTZ 1

INTRO PATTERN

INTRO 1	1st. measure	2nd. measure	3rd. measure	4th. measure
MAJOR	C	G ₇	C	C
MINOR	C _m	C _m	G ₇	C _m
7th	C ₇	C ₇	C ₇	C ₇

INTRO 2	1st. measure	2nd. measure	3rd. measure	4th. measure
MAJOR	C	C	C	G C
MINOR	C _m	A ^b ₇	C _m / G	G ₇ C _m
7th	C ₇	C ₇	C ₇	C ₇

INTRO 3	1st. measure	2nd. measure	3rd. measure	4th. measure	5th. measure	6th. measure	7th. measure	8th. measure
MAJOR	C _m	C ₇ / B ^b	F / A	A ^b	C _m / G	F _m	B ^b	G ₇ / B

* Minor or 7th chords produce the same progression as major chords.

SOLO PATTERN

MAJOR	1st. measure	2nd. measure	3rd. measure	4th. measure	5th. measure	6th. measure	7th. measure	8th. measure
VERSE 1	C	C	C	C	C	C	C	C
VERSE 2	C	C	D _m	D _m	G ₇	G ₇	C	C
CHORUS 1	C	C ₇ / B ^b	F / A	D ₇	G	G ₇	C	C
CHORUS 2	C _m	C ₇ / B ^b	F / A	A ^b ₇	C _m / G	F _m	B ^b ₇	G ₇ / B

MINOR	1st. measure	2nd. measure	3rd. measure	4th. measure	5th. measure	6th. measure	7th. measure	8th. measure
VERSE 1	C _m	C _m	C _m	C _m	C _m	C _m	C _m	C _m
VERSE 2	C _m	C _m	G ₇	G ₇	G ₇	G ₇	C _m	C _m
CHORUS 1	C _m	F _m	B ^b	E ^b	A ^b	D _m ⁽⁻⁵⁾	G ₇	C _m
CHORUS 2	C _m	C ₇ / B ^b	F / A		C _m / G	F _m	B ^b	G ₇ / B

7th	1st. measure	2nd. measure	3rd. measure	4th. measure	5th. measure	6th. measure	7th. measure	8th. measure
VERSE 1	C ₇	C ₇	C ₇	C ₇	C ₇	C ₇	C ₇	C ₇
VERSE 2	C	C	D _m	D _m	G ₇	G ₇	C	C
CHORUS 1	C	$\frac{C_7}{B^b}$	$\frac{F}{A}$	D ₇	G	G ₇	C	C
CHORUS 2	C _m	$\frac{C_7}{B^b}$	$\frac{F}{A}$	A ^b	$\frac{C_m}{G}$	F _m	B ^b	$\frac{G_7}{B}$

ENDING PATTERN

ENDING 1	1st. measure	2nd. measure
MAJOR	C	C
MINOR	C _m	C _m
7th	C ₇	C ₇

ENDING 2	1st. measure	2nd. measure	3rd. measure	4th. measure	5th. measure	6th. measure	7th. measure	8th. measure
MAJOR	C	$\frac{C_7}{B^b}$	$\frac{F}{A}$	D ₇	G ₇	G ₇	C	C
MINOR	C _m	F _m	B ^b	E ^b	A ^b	D _{m7} ⁽⁻⁵⁾	G ₇	C _m

* 7th chords produce the same progression as major chords.

ENDING 3	1st. measure	2nd. measure	3rd. measure	4th. measure	5th. measure	6th. measure	7th. measure	8th. measure
MAJOR	C _m	$\frac{C_7}{B^b}$	$\frac{F}{A}$	A ^b ₇	$\frac{C_m}{G}$	G ₇	C	C

* Minor or 7th chords produce the same progression as major chords.



STYLE: 34 WALTZ 2

INTRO PATTERN

INTRO 1	1st. measure			2nd. measure			3rd. measure			4th. measure		
MAJOR	C			C			G7			C		
MINOR	C _m			C _m			G7			C _m		

* 7th chords produce the same progression as major chords.

INTRO 2	1st. measure			2nd. measure			3rd. measure			4th. measure		
MAJOR	C			C			C			G7		
MINOR	C _m			F _m			G7			C _m		

* 7th chords produce the same progression as major chords.

INTRO 3	1st. measure			2nd. measure			3rd. measure			4th. measure		
MAJOR	C			C			G7			C		
MINOR	C _m			C _m			G7			C _m		

* 7th chords produce the same progression as major chords.

SOLO PATTERN

MAJOR	1st. measure			2nd. measure			3rd. measure			4th. measure			5th. measure			6th. measure			7th. measure			8th. measure		
VERSE 1	C			C E			F			C			C G			C			G7			C		
VERSE 2	C			C			C			G7			G7			G7			G7			C		
CHORUS 1	C			C E			F			C			C G			C			G7			C		
CHORUS 2	C			D _m			G7			C			A _m			D _m			E7			A _m		

	1st. measure	2nd. measure	3rd. measure	4th. measure	5th. measure	6th. measure	7th. measure	8th. measure
VERSE 1	C _m	C _m	G ₇	G ₇	G ₇	G ₇	C _m	C _m
VERSE 2	C _m	C _m	C _m	G ₇	G ₇	G ₇	G ₇	C _m
CHORUS 1	C _m	G ₇	G ₇	C _m	C _m	G ₇	G ₇	C _m
CHORUS 2	C	D _m	G ₇	C	A _m	D _m	E ₇	A _m

* 7th chords produce the same progression as major chords.

ENDING PATTERN

ENDING 1	1st. measure	2nd. measure	3rd. measure	4th. measure
MAJOR	C	C	G ₇	C
MINOR	C _m	C _m	G ₇	C _m

* 7th chords produce the same progression as major chords.

ENDING 2	1st. measure	2nd. measure	3rd. measure	4th. measure
MAJOR	C	C	G ₇	C
MINOR	C _m	C _m	G ₇	C _m

* 7th chords produce the same progression as major chords.

ENDING 3	1st. measure	2nd. measure	3rd. measure	4th. measure	5th. measure	6th. measure	7th. measure	8th. measure
MAJOR	C	D _m	G ₇	C	$\frac{C_7}{E}$	F	G ₇	C

* Minor or 7th chords produce the same progression as major chords.



STYLE: 35 JAZZ WALTZ

INTRO PATTERN

INTRO 1	1st. measure	2nd. measure	3rd. measure	4th. measure	5th. measure	6th. measure	7th. measure	8th. measure
MAJOR	C _{M7}	C _{M7}	C _{M7}	C _{M7}	C _{M7}	C _{M7}	C _{M7}	C _{M7}
MINOR	C _m	C _m	C _m	C _m	C _m	C _m	C _m	C _m
7th	C ₇	C ₇	C ₇	C ₇	C ₇	C ₇	C ₇	C ₇

INTRO 2	1st. measure	2nd. measure	3rd. measure	4th. measure	5th. measure	6th. measure	7th. measure	8th. measure
MAJOR	C _{M7} G	D _{m7} G	E _{m7} G	D _{m7} G	E _{m7} C _{M7} G G	D _{m7} G	E _{m7} G	D _{m7} E _{m7} G G
MINOR	C _{m7} ⁽⁹⁾ G	D _{m7} ⁽⁹⁾ G	C _{m7} ⁽⁹⁾ G	D _{m7} ⁽⁹⁾ G	C _{m7} ⁽⁹⁾ C _{m7} ⁽⁹⁾ G G	D _{m7} ⁽⁹⁾ G	C _{m7} ⁽⁹⁾ G	D _{m7} ⁽⁹⁾ C _{m7} ⁽⁹⁾ G G
7th	C ₇ G	B ^b G	C ₇ ⁽⁹⁾ G	B ^b G	C ₇ ⁽⁹⁾ C ₇ G G	B ^b G	C ₇ ⁽⁹⁾ G	B ^b C ₇ ⁽⁹⁾ G G

INTRO 3	1st. measure	2nd. measure	3rd. measure	4th. measure	5th. measure	6th. measure	7th. measure	8th. measure
MAJOR	C _{M7}	A ₇ ⁽⁻¹³⁾ (-9)	D _{m7} ⁽⁹⁾	D [#] _{dim}	E _{m7} E ^b ₇ ⁽⁹⁾	D _{m7} ⁽⁹⁾ D ^b ₇ ⁽⁹⁾	C ₆ ⁽⁺⁹⁾	G ₇ ⁽¹³⁾
MINOR	C _{m7} ⁽⁹⁾	A _{m7} ⁽⁻⁵⁾	D ₇ ⁽⁺⁹⁾	G ₇ ⁽⁻¹³⁾	C _{m7} ⁽⁹⁾	D ^b ₇ ⁽⁹⁾	D _{m7} ⁽⁻⁵⁾	G ₇ ⁽⁻¹³⁾

* 7th chords produce the same progression as major chords.

SOLO PATTERN

MAJOR	1st. measure	2nd. measure	3rd. measure	4th. measure	5th. measure	6th. measure	7th. measure	8th. measure
VERSE 1	C _{M7}		B _{m7}	E ₇ ⁽⁻⁹⁾	A _{m7}	D ₇	D _{m7} ⁽⁹⁾	G ₇ ⁽¹³⁾
VERSE 2	C _{M7}		B _{m7} ⁽⁻⁵⁾	E ₇ ⁽⁻⁹⁾	A _{m7}	D ₇	D _{m7} ⁽⁹⁾	G ₇ ⁽¹³⁾
CHORUS 1	F _{M7}	F [#] _{m7} ⁽⁻⁵⁾ B ₇ ⁽⁻⁹⁾	E _{m7}	A ₇	D _{m7} ⁽⁹⁾	G ₇ ⁽¹³⁾ (-9)	E ₇ ⁽⁺⁹⁾ E ^b ₇ ⁽⁺⁹⁾	D ₇ ⁽⁺⁹⁾ D ^b ₇ ⁽⁺⁹⁾
CHORUS 2	F _{M7}	F [#] _{m7} ⁽⁻⁵⁾ B ₇ ⁽⁻⁹⁾	E _{m7}	A ₇ ⁽⁹⁾	D _{m7} ⁽⁹⁾	G ₇ ⁽¹³⁾ (-9)	E ₇ ⁽⁺⁹⁾ E ^b ₇ ⁽⁺⁹⁾	D ₇ ⁽⁺⁹⁾ D ^b ₇ ⁽⁺⁹⁾

STYLE: 35 JAZZ WALTZ

MINOR	1st. measure	2nd. measure	3rd. measure	4th. measure	5th. measure	6th. measure	7th. measure	8th. measure
VERSE 1	C _{m7}	F ₇	C _{m7}	F ₇	B ^b _{m7}	E ^b ₇	A ^b _{M7}	G ₇ ⁽⁻¹³⁾
VERSE 2	C _{m7}	F ₇	C _{m7}	F ₇	B ^b _{m7}	E ^b ₇	A ^b _{M7}	G ₇ ⁽⁻¹³⁾
CHORUS 1	F _{m7}	B ^b ₇	E ^b _{M7}	C _{m7}	F _{m7}	B ^b ₇	E ^b _{M7}	D _{m7} ⁽⁻⁵⁾ G ₇ ⁽⁻¹³⁾ ⁽⁻⁹⁾
CHORUS 2	C _{m7}	F ₇	C _{m7}	F ₇	B ^b _{m7}	E ^b ₇	A ^b _{M7}	G ₇ ⁽⁻¹³⁾

* 7th chords produce the same progression as major chords.

ENDING PATTERN

ENDING 1	1st. measure	2nd. measure	3rd. measure	4th. measure	5th. measure	6th. measure
MAJOR	C _{M7}	E ^b _{M7}	A ^b _{M7}	D ^b ₇	C ₆ ⁽⁺¹¹⁾ ₉	—
MINOR	C _{m7}	E ^b ₇	A ^b _{M7}	D ^b ₇	C _{M7} ⁽¹¹⁾ ₉	—

* 7th chords produce the same progression as major chords.

ENDING 2	1st. measure	2nd. measure	3rd. measure	4th. measure	5th. measure	6th. measure	7th. measure	8th. measure
MAJOR	$\frac{C_{M7}}{G}$	$\frac{D_{m7}}{G}$	$\frac{E_{m7}}{G}$	$\frac{D_{m7}}{G}$	F _{M7} E _{m7} D _{m7}	$\frac{F_{M7}}{G}$	A _{M7} ⁽⁹⁾	A _{M7} ⁽⁹⁾
MINOR	$\frac{C_{m7}^{(9)}}{G}$	$\frac{F_{M7}}{G}$	$\frac{C_{m7}^{(9)}}{G}$	$\frac{F_{M7}}{G}$	A ^b _{M7} G _{m7} F _{m7} ⁽⁹⁾	G ₇ ⁽⁻¹³⁾ ⁽⁻⁹⁾	C _{m7} ⁽⁹⁾	C _{m7} ⁽⁹⁾

* 7th chords produce the same progression as major chords.

ENDING 3	1st. measure	2nd. measure	3rd. measure	4th. measure	5th. measure	6th. measure	7th. measure	8th. measure
MAJOR	C _{M7}	C [#] _{dim}	D _{m7} ⁽⁹⁾	D [#] _{dim}	E _{m7} E ^b ₇ ⁽⁹⁾ D _{m7} ⁽⁹⁾	D ^b ₇ ⁽⁹⁾ C ₆ ⁽⁹⁾	C ₆ ⁽⁹⁾	C ₆ ⁽⁹⁾
MINOR	C _{m7} ⁽⁹⁾	A _{m7} ⁽⁻⁵⁾	D ₇ ⁽⁺⁹⁾	G ₇ ⁽⁻¹³⁾	C _{m7} ⁽⁹⁾ E ^b ₇ ⁽⁹⁾ D ₇ ⁽⁺⁹⁾	D ^b ₇ ⁽⁹⁾ C _{m7} ⁽⁹⁾		

* 7th chords produce the same progression as major chords.

