

YAMAHA

MIDI FOOT CONTROLLER

MFC2

Owner's Manual

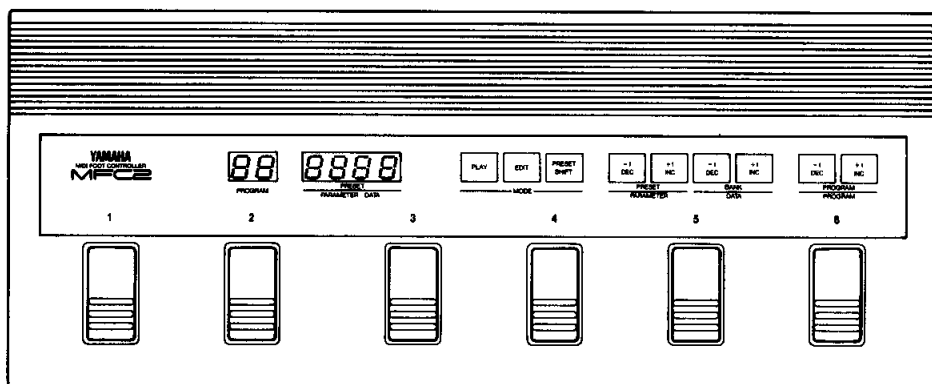

INTRODUCTION

Congratulations!

You are the proud owner of a Yamaha MFC2 MIDI Foot Controller which will greatly expand the versatility and expressive power of your WX7 MIDI Wind Controller. By simply tapping a bank select footswitch and one of six program select footswitches, you will be able to rapidly recall any of 30 different programs (voices) on a synthesizer or tone generator, offering easy access to a wider range of sounds. In addition, each program number has 6 different parameters which can be programmed to add new functions to the WX7. It is possible to have the WX7 control two different MIDI channels – and thus two different voices – simultaneously but in slightly different ways. A Key Hold footswitch can be used, for example, to hold a note on one channel while you continue to play on the other channel, while wind (volume/timbre) and lip (pitch) data from the WX7 has varying effects on each channel.

The MFC2 has a wide range of capabilities, and we recommend that you try out its many functions and features while carefully reading through this owner's manual.

CONTENTS

PRECAUTIONS	2	DESCRIPTIONS OF THE PARAMETERS	
CONTROLS AND CONNECTIONS	3	AND THEIR VALUES	8
SETTING UP	4	THE PRESET SHIFT MODE	11
MEMORY CONFIGURATION &		ERROR MESSAGES	11
OPERATIONAL OUTLINE	4	MIDI DATA FORMAT	12
THE PLAY MODE	5	SPECIFICATIONS	13
THE EDIT MODE	7	MIDI IMPLEMENTATION CHART	14

PRECAUTIONS

1. AVOID EXCESSIVE HEAT, HUMIDITY, DUST AND VIBRATION

Keep the unit away from locations where it is likely to be exposed to high temperatures or humidity — such as near radiators, stoves, etc. Also avoid locations which are subject to excessive dust accumulation or vibration which could cause mechanical damage.

2. AVOID PHYSICAL SHOCKS

Strong physical shocks to the unit can cause damage. Handle it with care.

3. DO NOT OPEN THE UNIT OR ATTEMPT REPAIRS OR MODIFICATIONS YOURSELF

This product contains no user-serviceable parts. Refer all maintenance to qualified Yamaha service personnel. Opening the unit and/or tampering with the internal circuitry will void the warranty.

4. MAKE SURE POWER IS OFF BEFORE MAKING OR REMOVING CONNECTIONS

Always turn the power OFF prior to connecting or disconnecting cables. This is important to prevent damage to the unit itself as well as other connected equipment.

5. HANDLE CABLES CAREFULLY

Always plug and unplug cables — including the AC cord — by gripping the connector, not the cord.

6. CLEAN WITH A SOFT DRY CLOTH

Never use solvents such as benzine or thinner to clean the unit. Wipe clean with a soft, dry cloth.

7. ALWAYS USE THE CORRECT POWER SOURCE

Make sure that the power source voltage specified on the rear panel matches your local AC mains supply.

8. ELECTRICAL INTERFERENCE

The MFC2 contains digital circuitry, and may cause interference if placed too close to television receivers or radio receivers, or other broadcast reception equipment. If interference occurs, move the MFC2 further away from the affected equipment.

9. BACKUP BATTERY

The MFC2 contains a special long-life battery which backs up the internal memory even when the power is turned OFF. With normal use the battery should last for about five years. If the "Lo bATT" display appears on the MFC2, indicating that the battery voltage is too low to safely maintain the stored data, have the battery replaced by qualified Yamaha service personnel. **DO NOT ATTEMPT TO REPLACE THE BATTERY YOURSELF!**

CONTROLS AND CONNECTIONS

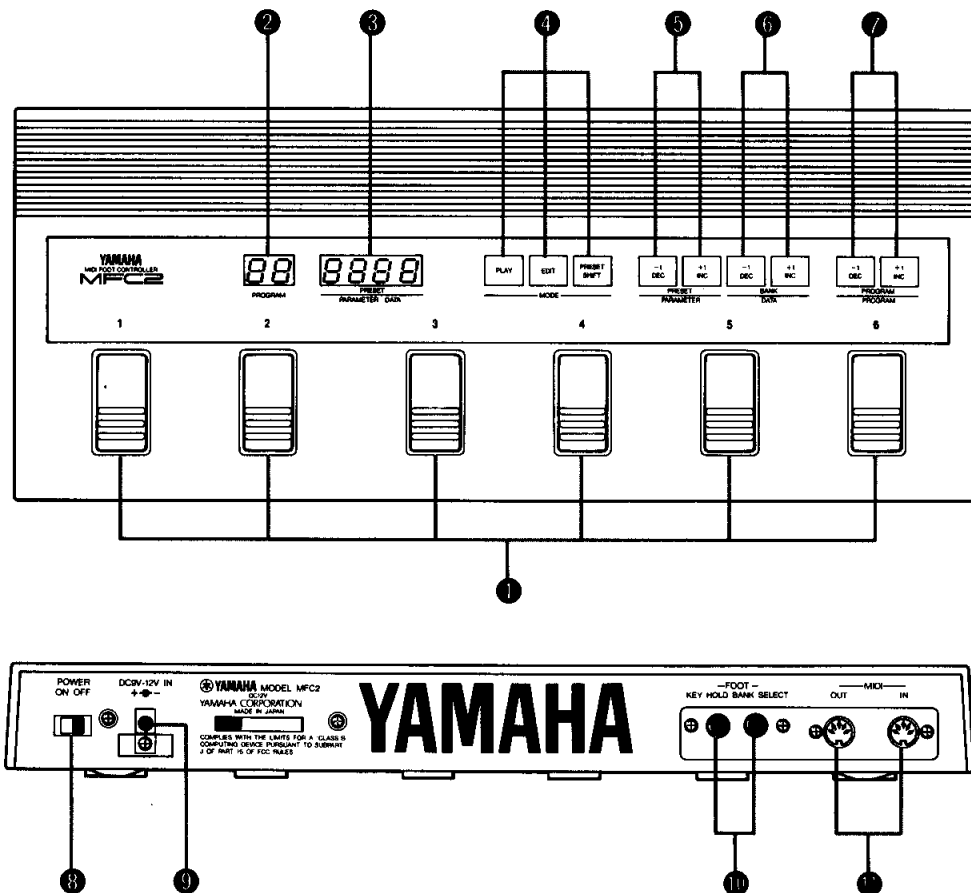

① Program Select Footswitches (1 through 6)

These footswitches select any of the 6 programs available in the currently selected BANK. 5 different BANKs can be selected using the BANK SELECT footswitch described below, giving a total of 30 programs which can be selected.

② Program LED Display

Shows the currently selected PROGRAM number (1 — 30).

③ Preset/Parameter Data LED Display

In the PLAY and PRESET SHIFT mode, this display shows the currently selected PRESET number. In the EDIT mode, it shows the select PARAMETER and its associated data.

④ Keys (PLAY, EDIT & PRESET SHIFT)

These keys directly select the MFC2's PLAY, EDIT and PRESET SHIFT modes.

⑤ Preset/Parameter Increment & Decrement Keys

In the PLAY and PRESET SHIFT modes these key increment (increase) or decrement (decrease) the selected PRESET number. In the EDIT mode they are used to increment or decrement the selected PARAMETER number.

⑥ Bank/Data Increment & Decrement Keys

In the PLAY and PRESET SHIFT modes these keys increment or decrement the selected BANK. The program select footswitches can then be used to select the desired PROGRAM within the selected BANK. In the EDIT mode they are used to increment or decrement the data value of the selected PARAMETER.

⑦ Program Increment & Decrement Keys

In all modes, these keys increment or decrement the selected PROGRAM number. Their function is similar to that of the program select footswitches.

⑧ Power Switch

Slide to the ON position to turn power ON, or to the OFF position to turn power OFF. The panel LED displays and one panel footswitch number will light when the power is turned ON.

⑨ DC 9V-12V IN Jack

The output cable from the supplied AC adapter is connected here. The AC adapter output cable can be looped around the cable anchor located just below this jack to prevent accidental unplugging.

⑩ Key Hold and Bank Select Footswitch Jacks

The supplied external footswitches are connected here. Either footswitch can be plugged into either jack.

⑪ MIDI IN and OUT Connectors

The MIDI data from the WX7 Wind MIDI Controller is received at the MIDI IN connector. The MIDI OUT connector transmits MIDI data generated and processed by the MFC2 to a synthesizer or tone generator.

SETTING UP

- ① Begin by connecting the supplied external footswitches to the BANK SELECT and KEY HOLD jacks on the MFC2 rear panel. Either footswitch can be plugged into either jack. Place the external footswitches in a convenient location beside the MFC2.
- ② Next, connect the MIDI OUT connector on the WX7 power pack/interface to the MIDI IN connector on the MFC2. If you will be standing up and moving about while playing, make sure that the MIDI cable used is long enough to permit freedom of movement. It's a good idea, however, not to use MIDI cables longer than about 15 meters, since longer cables can pick up noise that may affect operation.
- ③ Connect the MFC2 MIDI OUT connector to the MIDI IN connector of your synthesizer or tone generator.
- ④ If you will be using an additional synthesizer or tone generator to provide a second voice, connect the MIDI THRU connector from the first synthesizer or tone generator to the MIDI IN connector of the second synthesizer or tone generator.
- ⑤ Connect the supplied AC adapter output plug to the DC9V-12V IN jack on the MFC2 rear panel. The power cable can be looped around the cable anchor located just below the DC9V-12V IN jack to prevent accidental unplugging.
- ⑥ Plug the AC adaptor into a convenient AC outlet and turn the MFC2 POWER switch ON.

NOTE: Make sure your synthesizer(s) and/or tone generator(s) are set to receive on the MIDI channel(s) on which the MFC2 is transmitting. Initially, the MFC2 main channel is set to MIDI channel 1 and the sub channel to MIDI channel 2.

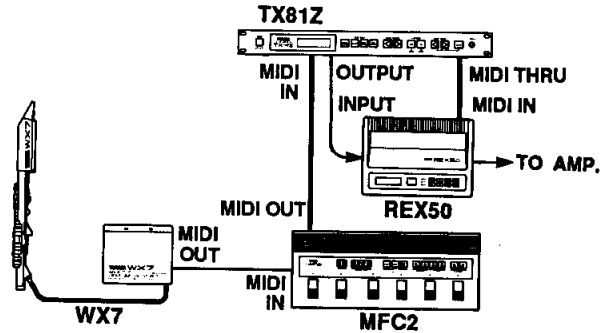

In the sample system shown here, we've used a TX81Z FM Tone Generator to provide a wide range of FM voices. The TX81Z output is connected to an REX50 Multi-effector to add reverberation, delay, chorus, pitch change and other effects to the TX81Z sound.

MEMORY CONFIGURATION & OPERATIONAL OUTLINE

The MFC2 has eight PRESETS, each of which contains 30 PROGRAMS. Each PROGRAM contains 6 PARAMETERS (except for PROGRAM 1 in each PRESET which has 7 PARAMETERS).

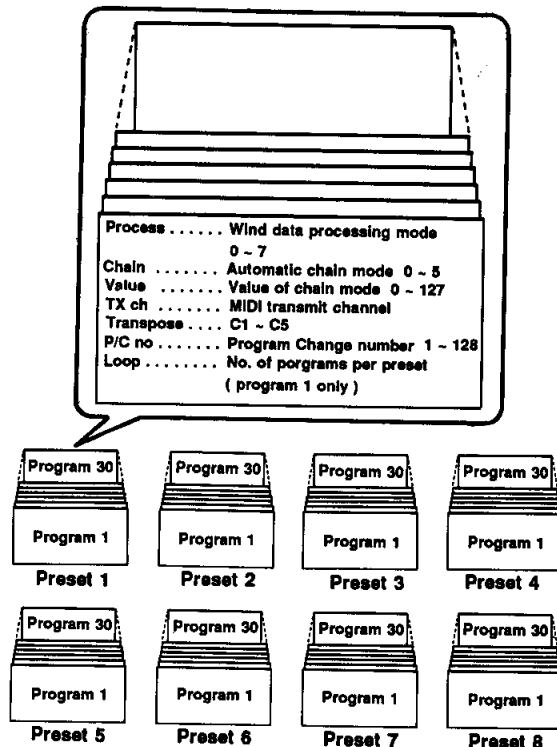

The **PARAMETERS** are used to set up important operational modes for each program:

PARAMETER 1 (PROCESS SELECT) determines how the **KEY HOLD** footswitch will function, and how certain types of MIDI data from the WX7 Wind MIDI Controller will be assigned to the main and sub MIDI channels.

PARAMETER 2 (CHAIN) and PARAMETER 3 (VALUE) make it possible to automatically increment the **PROGRAM** number when a specified note is played on the WX7, when a specified note is released, when a specified breath pressure is exceeded, or when a specified degree of pitch bend is exceeded.

PARAMETER 4 (TX CHANNEL) sets the main MIDI transmission channel for the selected **PROGRAM**.

PARAMETER 5 (TRANSPOSE) makes it possible to transpose the note input from the WX7 over a ± 2 -octave range.

PARAMETER 6 (P/C NO.) sets the MIDI program change number which will be transmitted when the corresponding **PROGRAM** is selected, thus determining the number of the voice that will be selected on your synthesizer or tone generator.

PARAMETER 7 (LOOP) is available only on **PROGRAM 1** in each **PRESET**. **LOOP** makes it possible to limit the number of **PROGRAMS** which are selected using the footswitches when only a few are needed, cycling back to the first program in the "loop" after the last has been selected.

All these **PARAMETERS** go into effect whenever you select one of the 30 **PROGRAMS** within each **PRESET**.

The **PRESETS** simply allow you to have up to eight completely different sets of programs with different parameters available for use at any time. You could, for example, program each **PRESET** with different parameters that will be used in different "sets" during a performance.

As you can see, the **MFC2** is much more than a simple MIDI program switcher, and you will need to carefully set up the various parameters to produce the results you want. Once this is done, however, all you have to do is press the footswitches and play.

THE PLAY MODE

The **PLAY MODE** is the mode in which you will normally use the **MFC2** while playing the WX7. The **PLAY MODE** allows you to select previously set up **PROGRAMS** using the **MFC2**'s footswitches, thus selecting appropriate voices on your synthesizer or tone generator and activating the corresponding parameters. We'll discuss the **PLAY MODE** first so that you can try out the **MFC2** with the initial factory-preset **PARAMETERS**, which are as follows and are the same for all programs:

PARAMETER 1 (PROCESS SELECT) is set to a value of "1" (Breath). This means that the MIDI sub-channel is active and that a second voice or tone generator set to receive on the sub-channel can be controlled simultaneously with the main-channel voice. The **KEY HOLD** footswitch is also active, so that by pressing it you can hold a note on the sub-channel voice while continuing to play over it using the main-channel voice. The initial setting for the main MIDI channel is channel 1 (see **PARAMETER 4**, below), and the sub-channel is always the next highest MIDI channel (in this case, channel 2). If you have a multi-voice tone generator or two tone generators, set up two different voices to receive on these channels to try out this effect.

PARAMETER 2 (CHAIN) and PARAMETER 3 (VALUE) are set for no chain operation.

PARAMETER 4 (TX CHANNEL) is set to MIDI channel 1. The sub-channel is therefore channel 2.

PARAMETER 5 (TRANSPOSE) is set to "C3" (no transposition).

PARAMETER 6 (P/C NO.) is set so that **PROGRAMS 1** through 30 transmit the corresponding program change numbers (1 — 30). This means that if you select **PROGRAM 10** on the **MFC2**, voice number 10 will be selected on your synthesizer or tone generator, and so on.

PARAMETER 7 (LOOP) is set so that the maximum number of **PROGRAMS** can be selected (30).

PLAY MODE OPERATION

- ① Make sure that your system is properly set up and that your synthesizer or tone generator(s) is set to receive on the appropriate MIDI channel(s).
- ② Press the PLAY MODE key to enter the PLAY MODE. At this point the currently selected PROGRAM number will be shown on the PROGRAM LED display, and the currently selected PRESET number will be shown on the PRESET LED display.
- ③ Use the BANK SELECT footswitch and the six footswitches on the MFC2 panel to select the desired program. The number above the selected panel footswitch will light to show that it has been selected.

① SET UP SYSTEM

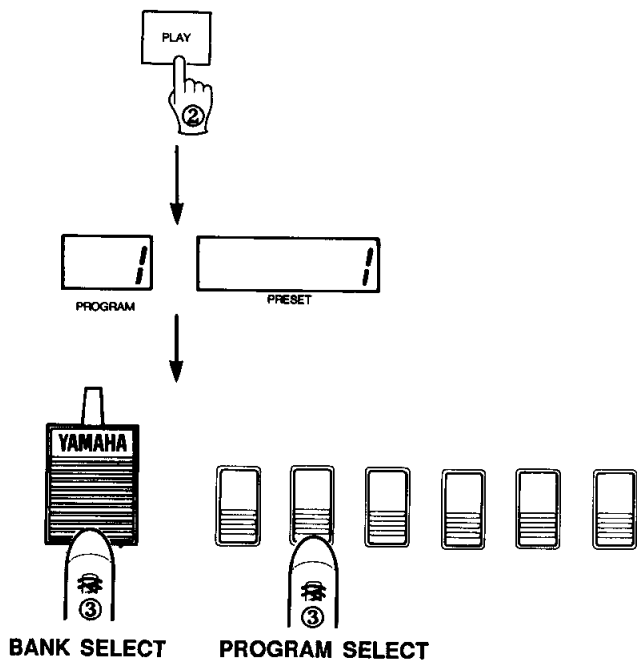

There are 5 BANKS, and the MFC2 footswitches select the 6 programs available in each BANK. The first BANK contains PROGRAMS 1 through 6, the second BANK contains PROGRAMS 7 through 12, and so on up to PROGRAM 30 in the last BANK. If for example, you are in BANK 1 and have selected PROGRAM 2, and then you press the BANK SELECT footswitch the newly selected PROGRAM will be PROGRAM 8. If you press the BANK SELECT footswitch again PROGRAM 14 will be selected. Press the BANK SELECT footswitch three more times and PROGRAMS 20, 26, and finally 2 will be selected. Note that the BANK SELECT function "wraps around" so that the first BANK is re-selected after the last BANK.

- ④ Use the KEY HOLD switch when needed to create the effect specified by the value of PARAMETER 1.

In the PLAY MODE the panel BANK DEC (decrement) and INC (increment) keys can also be used to select a new BANK. Likewise, the panel PROGRAM INC and DEC keys can be used to select any PROGRAM. All of these keys feature continuous incrementing or decrementing, so if you hold one down you can rapidly search for a desired BANK or PROGRAM in the specified "direction." In the PLAY mode, the panel PRESET DEC and INC keys can be used in the same way to select a new PRESET.

THE EDIT MODE

The EDIT mode allows you to set up the PARAMETERS for each PROGRAM.

- ① In the PLAY mode select the PROGRAM number for which you wish to edit PARAMETERS.
- ② Press the EDIT MODE key to enter the EDIT mode. The selected PROGRAM number will be shown on the PROGRAM LED display as before, but the PARAMETER DATA LED display will now show the number of the currently selected parameter on the left and its value on the right. The number above the currently selected panel footswitch should be flashing. Note that the green label on the LED display applies in the EDIT mode rather than the upper white label. The same applies to keys with green labels below their white labels. The function marked in green is the one that is active while in the EDIT mode.
- ③ Select the PARAMETER you wish to edit using the PARAMETER DEC and INC keys.
- ④ Set the desired value for the selected parameter using the DATA DEC and INC keys. Refer to "DESCRIPTIONS OF THE PARAMETERS AND THEIR VALUES," below, for details.
- ⑤ If necessary, select the next PARAMETER and edit its value as described above.
- ⑥ If necessary, select a new PROGRAM using the PROGRAM DEC and INC keys, and edit its parameters as described above.
- ⑦ Press the PLAY MODE key to return to the PLAY mode.

① SELECT PROGRAM TO EDIT

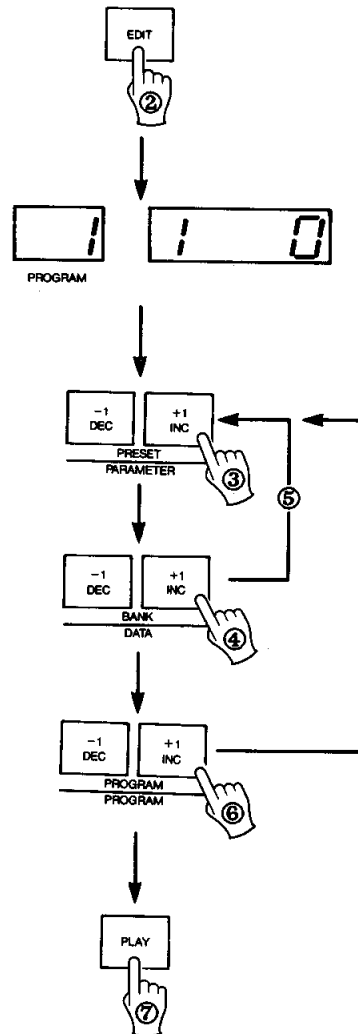

DESCRIPTIONS OF THE PARAMETERS AND THEIR VALUES

PARAMETER 1: Process Select

■ Parameter 1 = 0 (Bypass Mode)

The sub-channel is inactive and only the main channel will sound. The KEY HOLD footswitch is inoperative.

■ Parameter 1 = 1 (Breath Mode)

When the KEY HOLD footswitch is not pressed, both the main and sub-channel voices can be played simultaneously. When the KEY HOLD footswitch is pressed, the sub-channel note is fixed at the selected pitch and further notes played affect the main channel only. Wind (breath pressure) and lip (bend) data affect both the main and sub-channels. When the KEY HOLD footswitch is released, the sub-channel note automatically switches to the note being played on the main channel.

[BREATH MODE]

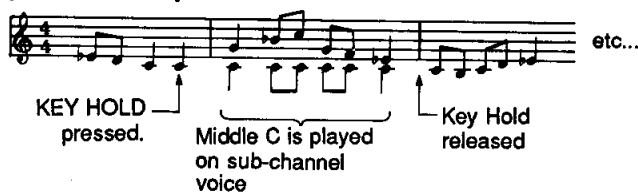

■ Parameter 1 = 2 (No Breath Mode)

When the KEY HOLD footswitch is not pressed, both the main and sub-channel voices can be played simultaneously. When the KEY HOLD footswitch is pressed, the sub-channel note is held at its current wind (breath pressure) level and further notes played affect the main channel only. Lip (bend) data affects both the main and sub-channel voices, but wind (breath pressure) affects only the main voice.

[NO BREATH MODE]

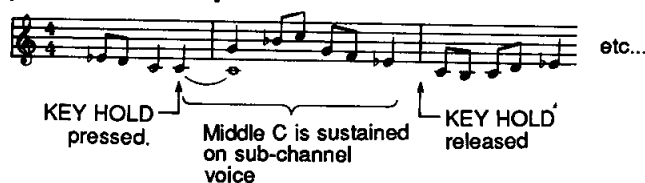

■ Parameter 1 = 3 (No Breath & Lip Mode)

When the KEY HOLD footswitch is not pressed, both the main and sub-channel voices can be played simultaneously. When the KEY HOLD footswitch is pressed, the sub-channel note is held at its current wind (breath pressure) and lip (bend) levels and further notes played affect the main channel only. During HOLD, wind and lip data affect only the main voice.

■ Parameter 1 = 4 (Maximum Breath Mode)

When the KEY HOLD footswitch is not pressed, both the main and sub-channel voices can be played simultaneously. When the KEY HOLD footswitch is pressed, the wind (breath pressure) value at that instant is memorized and becomes the maximum breath level applicable to the sub-channel voice. The main-channel voice can be played normally during KEY HOLD.

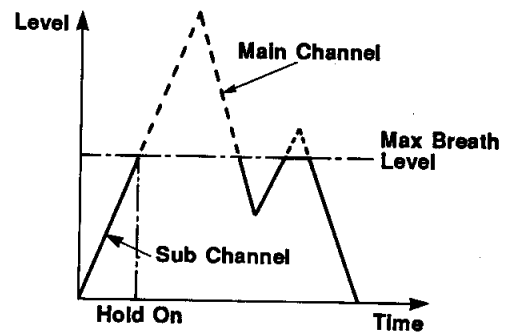

■ Parameter 1 = 5 (Threshold Breath Mode)

When the KEY HOLD footswitch is not pressed, only the main-channel voice can be played. When the KEY HOLD footswitch is pressed, the sub-channel voice is activated and held at the current note and further notes played affect the main channel only. The sub-channel voice is played at a wind level which is that of the applied wind level minus that at the time the KEY HOLD footswitch was pressed. Pitch bend affects the sub-channel voice while it is active.

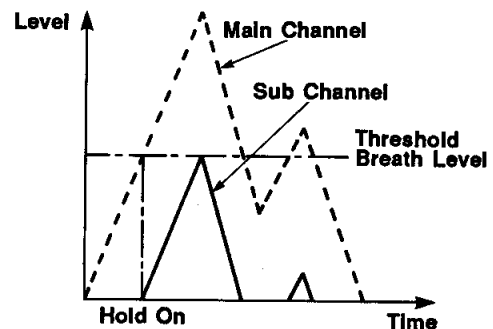

■ **Parameter 1 = 6 (Instant Breath Mode)**

When the KEY HOLD footswitch is not pressed, only the main-channel voice can be played. When the KEY HOLD footswitch is pressed, the sub-channel voice is activated and held at the current note and further notes played affect the main channel only. Wind (breath pressure) and lip (bend) data affect both the main and sub-channels.

■ **Parameter 1 = 7 (Reverse Breath Mode)**

When the KEY HOLD footswitch is not pressed, both the main and sub-channel voices can be played simultaneously. When the KEY HOLD footswitch is pressed, the wind (breath pressure) value at that instant is memorized and the sub-channel note is held and further notes played affect the main channel only. Lip (bend) data affects both the main and sub-channels, wind (breath pressure) affects the main channel normally. Wind values less than the memorized value (the breath pressure at the instant the KEY HOLD footswitch was pressed) affect the sub-channel voice as-is, while breath pressures greater than this value are transmitted to the sub-channel as the difference between the current and memorized values.

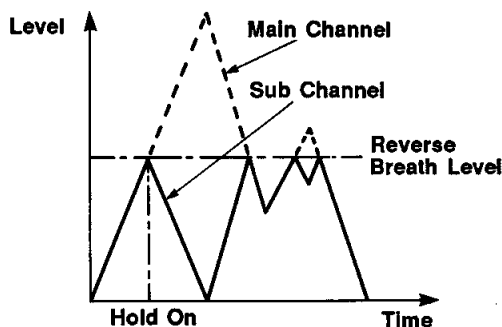

Sub channel parameter operation

Parameter	Hold sw off		Hold sw on	
	Cont. change & after touch	Pitch bend	Cont. change & after touch	Pitch bend
0: Bypass mode [solo mode]	No	No	No	No
1: Breath mode	Yes	Yes	Yes	Yes
2: No breath mode	Yes	Yes	No	Yes
3: No breath & lip mode	Yes	Yes	No	No
4: Maximum breath mode	Yes	Yes	Yes *	Yes
6: Threshold breath mode	No	Yes	Yes	Yes
6: Instant breath mode	No	Yes	Yes	Yes
7: Reverse breath mode	Yes	Yes	Yes	Yes

* Below maximum breath level.

Note: The WX7's own key hold modes 1 and 2 can be used in conjunction with the MFC2 key hold functions. By combining the WX7 and MFC2 key hold functions, it is possible to create a broad variety of effects.

PARAMETER 2: Chain

PARAMETER 3: Value

These two parameters work together to automatically increment the PROGRAM number by one when certain conditions are met.

■ **Parameter 2 = 0**

No chain (automatic PROGRAM incrementing) occurs, regardless of the setting of PARAMETER 3.

■ **Parameter 2 = 1**

The PROGRAM number is automatically incremented by one when the key (note) specified by PARAMETER 3 is played. The PARAMETER 3 data range is from 0 to 127. A setting of 60 corresponds to the note C3 (middle C), 61 corresponds to C#3, 72 corresponds to C4, etc.

■ **Parameter 2 = 2**

The PROGRAM number is automatically incremented by one when the key (note) specified by PARAMETER 3 is released. The PARAMETER 3 data range is from 0 to 127. A setting of 60 corresponds to the note C3 (middle C), 61 corresponds to C#3, 72 corresponds to C4, etc.

■ **Parameter 2 = 3**

The PROGRAM number is automatically incremented by one when a control change or after touch (breath pressure) value exceeding that specified by PARAMETER 3 is received. The PARAMETER 3 data range is from 0 to 127, with 0 representing no breath pressure and 127 representing the highest breath pressure. A setting of 64 causes the increment to occur when "middle" breath pressure is exceeded.

■ **Parameter 2 = 4**

The PROGRAM number is automatically incremented by one when a lip (pitch bend) value exceeding that specified by PARAMETER 3 is received. The PARAMETER 3 data range is from 0 to 127, with 0 representing no pitch bend and 127 representing maximum pitch bend. A setting of 64 causes the increment to occur when about the middle of the pitch bend range is exceeded.

PARAMETER 4: Transmission Channel

This parameter sets the main MIDI transmission channel. The PARAMETER 4 data range is from 1 to 16, with each value representing the correspondingly numbered MIDI channel. The sub-channel is automatically set to the main MIDI channel number plus one, except when the main MIDI channel is set to 16, in which case the sub-channel becomes 1.

PARAMETER 5: Transpose

This parameter transposes notes received from the WX7 up or down by up to 2 octaves in semitone steps. The PARAMETER 5 data range is from C1 to C5. A setting of C3 (middle C) causes no transposition. To transpose up a semitone, for example, press the DATA INC key once. The display will now read "C.3," the dot after the "C" representing a # (sharp) sign. To transpose up a third set to "d3," to transpose down an octave set to "C2," etc.

PARAMETER 6: Program Change Number

This parameter determines which MIDI program change number will be transmitted when the corresponding program is selected on the MFC2. The PARAMETER 6 data range is from 1 to 128. If, for example, you set this parameter to "32" for MFC2 PROGRAM number 1, when you select PROGRAM 1 on the MFC2 voice number 32 will be selected on your synthesizer or tone generator.

* The actual voice number selected may vary according to the type of equipment you use. Refer to your Keyboard/ tone generator owner's manual for details.

PARAMETER 7: Loop

This parameter is available only in PROGRAM 1 of each PRESET, and sets the maximum number of PROGRAMS which can be selected in that PRESET. The PARAMETER 7 data range is from 1 to 30. If you set this parameter to "3," for example, only PROGRAMS 1, 2 and 3 will be selectable. If you use the BANK SELECT or panel footswitches to select a PROGRAM number higher than number 3, number 3 will be selected. If you have a CHAIN set up in PROGRAM 3, the next PROGRAM selected will be number 1 rather than number 4.

THE PRESET SHIFT MODE

The PRESET SHIFT mode allows you to switch between presets using the KEY HOLD footswitch.

1. Press the PRESET SHIFT MODE key to enter the PRESET SHIFT mode. It is also possible to enter the PRESET SHIFT mode by holding down the BANK SELECT footswitch for longer than 2 seconds. The current PRESET number will be shown on the PRESET LED display as in the PLAY mode. The currently selected panel footswitch number will flash alternately with the un-selected footswitch numbers.
2. Press the KEY HOLD footswitch to increment the PRESET number. When PRESET number 8 is reached, the next press on the footswitch returns to PRESET 1.
3. Press the BANK SELECT footswitch to return to the PLAY mode.

All other panel keys and footswitches function exactly as they do in the PLAY mode.

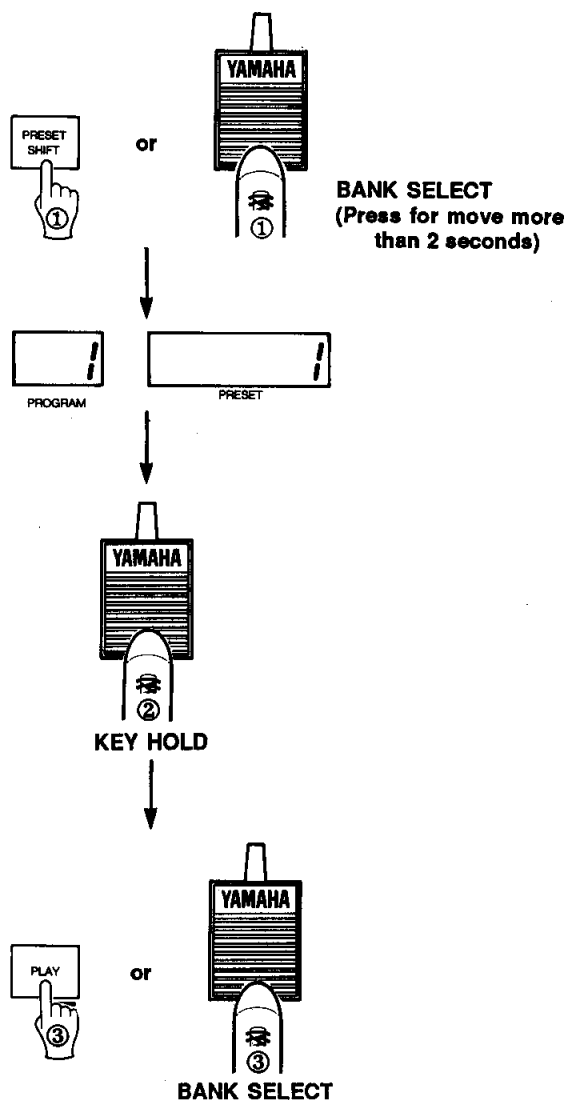

ERROR MESSAGES

Should an error occur while using the MFC2, the one of the following error messages will appear on the LED displays to give you an idea of what the problem might be:

Er **LINE**

This message appears if a 300 millisecond or longer break occurs in the incoming data. Usually indicates a bad connection or cable, sometimes a fault in the equipment from which the MIDI data is being received.

Er **FULL**

A MIDI buffer overflow has occurred. Too much data is being received.

Er **DATA**

Improper MIDI data received (framing error).

Er **BATT**

The internal battery is low and must be replaced BY QUALIFIED YAMAHA SERVICE PERSONNEL.

Er **LOSS**

Internal data has been erased and replaced by the initial data.

MIDI DATA FORMAT

1. RECEPTION CONDITIONS

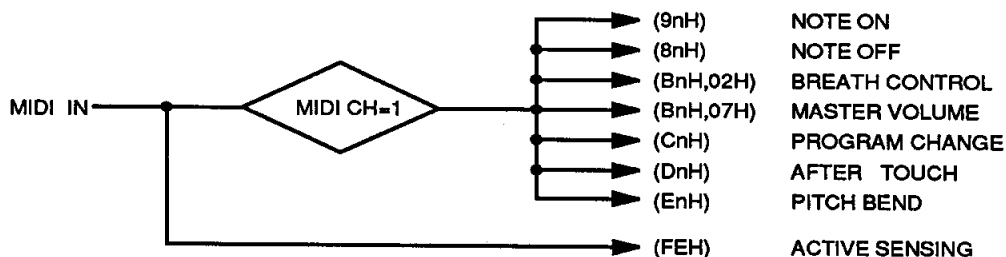

2. TRANSMISSION CONDITIONS

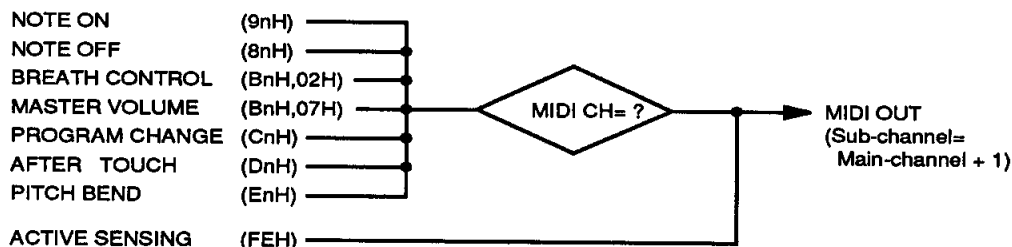

3. RECEPTION & TRANSMISSION DATA

3.1 Reception Channel

The MFC2 receives data only on MIDI channel 1.

3.2 NOTE ON/OFF

Basically, received note on and note off messages are re-transmitted on two MIDI channels: the specified main channel and the sub channel (sub-channel = main-channel + 1). The full range of MIDI note and velocity data can be both received and transmitted by the MFC2. However, the MFC2 will re-transmit a maximum of three polyphonic note on/off messages at a time. Note on/off transmission on the sub-channel depends on the setting of the PROCESS SELECT parameters (refer to page 8).

Note ON

STATUS	1001nnnn (9nH)	n = 0 (ch1) – 15 (ch16)
NOTE NO.	0kkkkkkk	k = 21 – 122
VELOCITY	0vvvvvvv	v = 1 – 127. 0 = note off

Note OFF

STATUS	1000nnnn (8nH)	n = 0 (ch1) – 15 (ch16)
NOTE NO.	0kkkkkkk	k = 21 – 122
VELOCITY	00000000 (00H)	

3.3 CONTROL CHANGE

As with note on and off data, received control change messages are re-transmitted on two MIDI channels: the specified main channel and the sub channel (sub-channel = main-channel + 1). The full range of MIDI control change data can be both received and transmitted by the MFC2. Control change transmission on the sub-channel depends on the setting of the PROCESS SELECT parameters (refer to page 8).

STATUS	1011nnnn (BnH)	n = 0 (ch1) – 15 (ch16)
CONTROL NO.	0ccccccc	
CONT. VALUE	0vvvvvvv	

3.4 PROGRAM CHANGE

Received program change messages are re-transmitted on two MIDI channels: the specified main channel and the sub channel (sub-channel = main-channel + 1). The full range of MIDI program change data can be both received and transmitted by the MFC2.

STATUS	1100nnnn (CnH)	n = 0 (ch1) – 15 (ch16)
PROGRAM NO.	0pppppppp	

3.5 AFTER TOUCH

Received after touch messages are re-transmitted on two MIDI channels: the specified main channel and the sub channel (sub-channel = main-channel + 1). The full range of MIDI after touch data can be both received and transmitted by the MFC2. After touch transmission on the sub-channel depends on the setting of the PROCESS SELECT parameters (refer to page 8).

STATUS 1101nnnn (DnH) n = 0 (ch1)– 15 (ch16)
DATA 0ddddddd data = 0– 127

3.6 PITCH BEND

Received pitch bend messages are re-transmitted on two MIDI channels: the specified main channel and the sub channel (sub-channel = main-channel + 1). However, the resolution of the received pitch bend data is converted to 128 steps before re-transmission. Pitch bend transmission on the sub-channel depends on the setting of the PROCESS SELECT parameters (refer to page 8).

STATUS 1110nnnn (EnH) n = 0 (ch1) – 15 (ch16)
DATA (low) 0LLLLLLL
DATA (high) 0hhhhhhh

3.7 ACTIVE SENSING

The active sensing message is transmitted at least every 270 milliseconds. On the reception side, an error is assumed if an active sensing message is not received for more than 300 milliseconds. In this case, all transmission will be halted for approximately 0.5 seconds.

STATUS 11111110 (FEH)

SPECIFICATIONS

Memory

8 PRESETS, each with 30 PROGRAMS.
Each program has 6 PARAMETERS (7
PARAMETERS in PROGRAM 1)

Operational Modes

PLAY, EDIT, PRESET SHIFT

Edit Mode Parameters

Process select, Chain, Value,
TX Channel, Transpose, Program change
number, Loop (PROGRAM 1 only)

Panel Keys

PLAY, EDIT, PRESET SHIFT,
PRESET/PARAMETER INC & DEC,
BANK/DATA INC & DEC,
PROGRAM INC & DEC

Footswitches

PROGRAM SELECT x 6 (on panel),
BANK SELECT (external),
KEY HOLD (external)

Connectors

DC(9V-12V) IN, BANK SELECT,
KEY HOLD, MIDI IN, MIDI OUT

Displays

PROGRAM (2-digit 7-segment),
PRESET/PARAMETER DATA (4-digit,
7-segment)

Dimensions (W x H x D)

466 x 53 x 197 mm

Weight

1.7 kg

Supplied Accessories

FC5 Footswitch x 2,
PA-1 AC Adapter x 1

• Specifications are subject to change without notice.

Function ...	Transmitted	Recognized	Remarks
Basic Default	: 1 - 16	: 1	
Channel Changed	: 1 - 16 *		*memorized
Mode Default	: x	: x	
Mode Messages	: x	: x	
Mode Altered	: *****		
Note Number	: 0 - 127	: 0 - 127	
Note True voice	: *****		
Velocity Note ON	: o 9nH,v=1-127	: o	
Velocity Note OFF	: x 9nH,v=0	: x	
After Key's	: x	: x	
Touch Ch's	: o	: o	
Pitch Bender	: o	: o	: 7 bit resolution
	0-121: o	: o	
Control Change			
Prog Change	: True #		
	: o 0-127	: o 0-127	
	: *****		
System Exclusive	: x	: x	
System Common	: Song Pos : x	: x	
	: Song Sel : x	: x	
	: Tune : x	: x	
System Real Time	: Clock : x	: x	
	: Commands : x	: x	
Aux Messages	: Local ON/OFF : x	: x	
	: All Notes OFF : x	: x	
	: Active Sense : o	: o	
	: Reset : x	: x	
Notes			

FCC INFORMATION

While the following statements are provided to comply with FCC Regulations in the United States, the corrective measures listed below are applicable worldwide.

This series of Yamaha professional music equipment uses frequencies that appear in the radio frequency range and if installed in the immediate proximity of some types of audio or video devices (within three meters), interference may occur. This series of Yamaha combo equipment have been type tested and found to comply with the specifications set for a class B computing device in accordance with those specifications listed in subpart J of part 15 of the FCC rules. These rules are designed to provide a reasonable measure of protection against such interference. However, this does not guarantee that interference will not occur. If your professional music equipment should be suspected of causing interference with other electronic devices, verification can be made by turning your combo equipment off and on. If the interference continues when your equipment is off, the equipment is not the source of interference. If your equipment does appear to be the source of the interference, you should try to correct the situation by using one or more of the following measures:

Relocate either the equipment or the electronic device that is being affected by the interference. Utilize power outlets for the professional music equipment and the device being affected that are on different branch (circuit breaker or fuse) circuits, or install AC line filters.

In the case of radio or TV interference, relocate the antenna or, if the antenna lead-in is 300 ohm ribbon lead, change the lead-in the co-axial type cable.

If these corrective measures do not produce satisfactory results, please contact your authorized Yamaha professional products dealer for suggestions and/or corrective measures.

If you cannot locate a franchised Yamaha professional products dealer in your general area, contact the professional products Service Department, Yamaha Music Corporation, 6600 Orangethorpe Ave., Buena Park, CA 90620, U.S.A.

If for any reason, you should need additional information relating to radio or TV interference, you may find a booklet prepared by the Federal Communications Commission helpful:

"How to identify and Resolve Radio - TV Interference Problems". This booklet is available from the U.S. Government Printing Office, Washington D.C. 20402 - Stock No. 004-000-00345-4.

SERVICE

This product is supported by Yamaha's worldwide network of factory trained and qualified dealer service personnel. In the event of a problem, contact your nearest Yamaha dealer.

YAMAHA
YAMAHA CORPORATION
P.O. Box 1, Hamamatsu, Japan