

Roland

TEACHING LABORATORY SYSTEM TL-12

The Introduction of the Teaching Laboratory TL-12

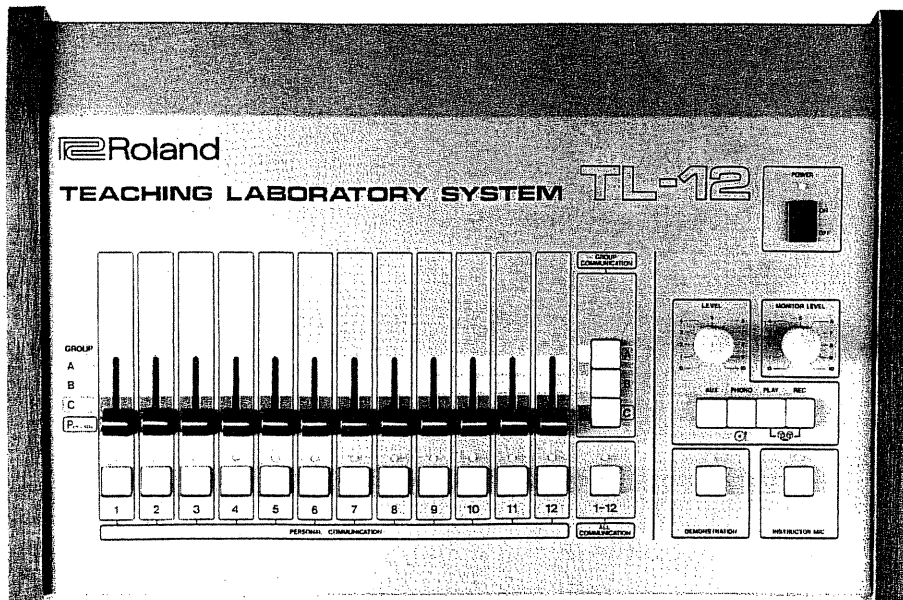

CONTENTS

INTRODUCTION	3
1 Front Panel Layout	5
2 Connections	6
3 Communications	8
(1) Instructor ↔ The whole class	
(2) Instructor ↔ Individual	
(3) Instructor ↔ Groups	
(4) Demonstration	
(5) Communication OFF	
(6) Adjusting the Volume Level	
4 Applications	11
(7) Connecting a Record-Player	
(8) Connecting a Tape-Recorder	
(9) Connecting a Rhythm Machine	
(10) Connecting the PA System	
(11) Adding other Main unit	
5 Functions	15
Specifications	18

The Introduction of The Teaching Laboratory TL-12

INTRODUCTIONS

The Roland Teaching Laboratory TL-12 is designed to be used for the music education. There is no extra musical instrument or special installation needed, thus setting up is extremely easy. The TL-12 enables Instructor to successfully give a lesson to a group of students, using an electronic piano or a synthesizer. (Any of the Roland keyboards can be used.)

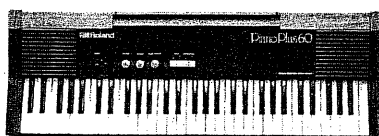

Electronic Piano: HP-30, 60 & 70

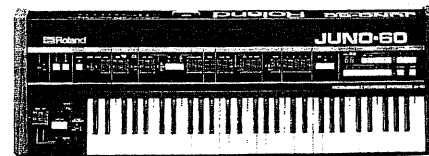
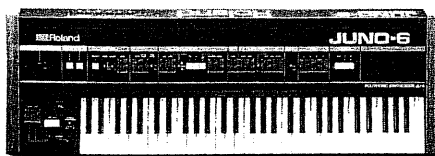
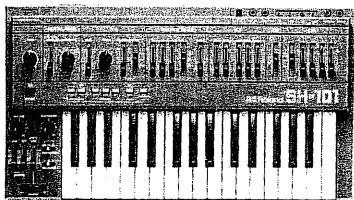

Synthesizer: SH-101

JUNO-6, JUNO-60

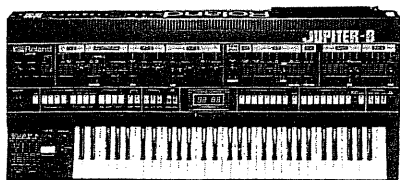

JUPITER-8

* One set of the Main Unit of the TL-12 can control up to 12 students. For the bigger class, you can add up to 3 more Main Units, allowing maximum of 48 students.

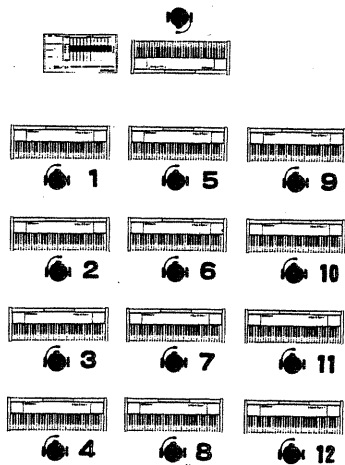

* You can divide the 12 students within one Main Unit into 3 groups A, B & C to give them 3 different lessons separately. Also, individual instruction to each student is possible by changing modes.

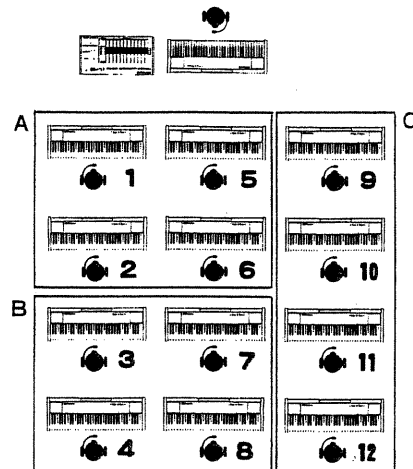

* By connecting external units such as a tape-recorder, record-player and rhythm machine, playing records and recording the performance are made possible. Thus, the lesson can have a wide variation.

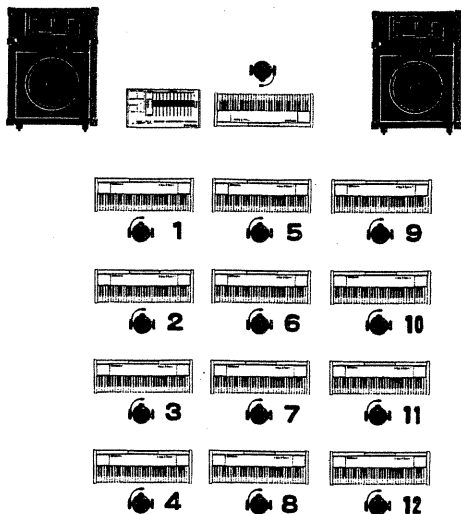

* Setting up the TL-12 does not require special installation. You can set up the units, only by using the necessary Connecting boxes and cables depending on the number of the students and the size of the classroom.

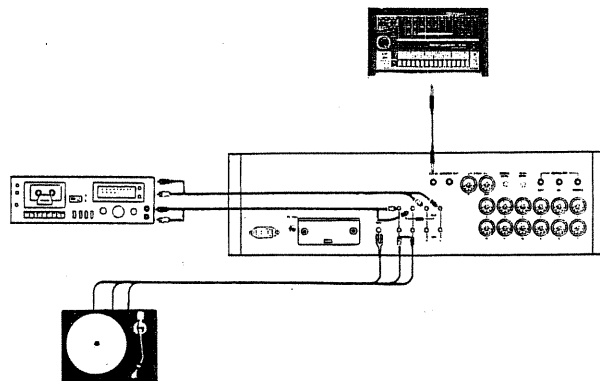

1. Front Panel Layout

< TL-12 >

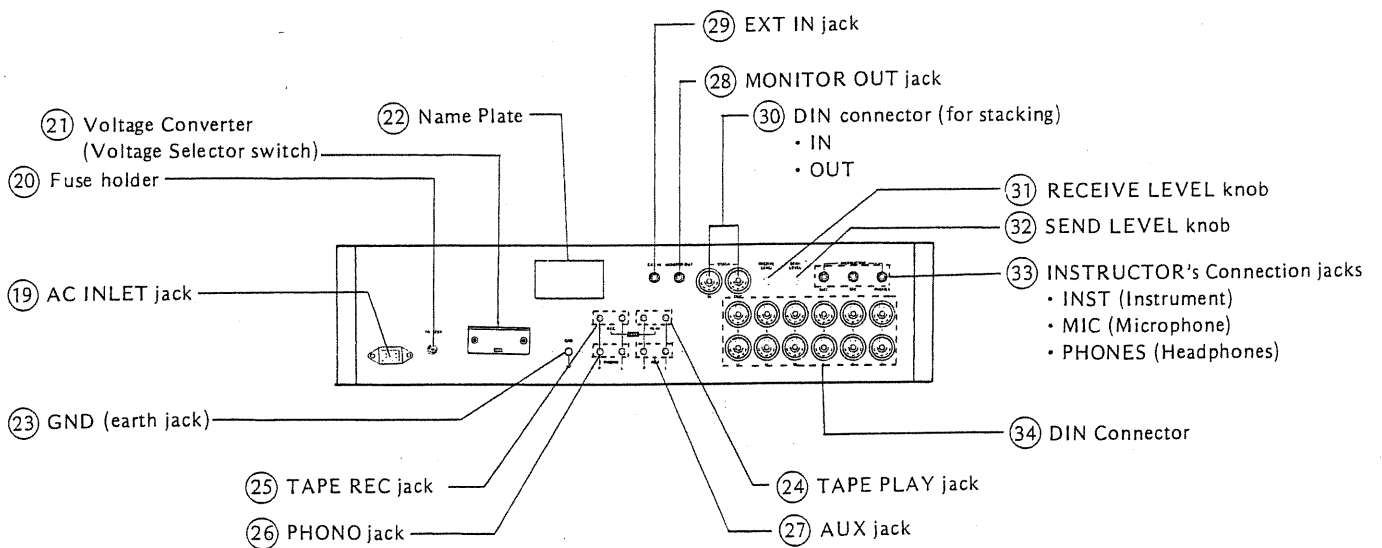
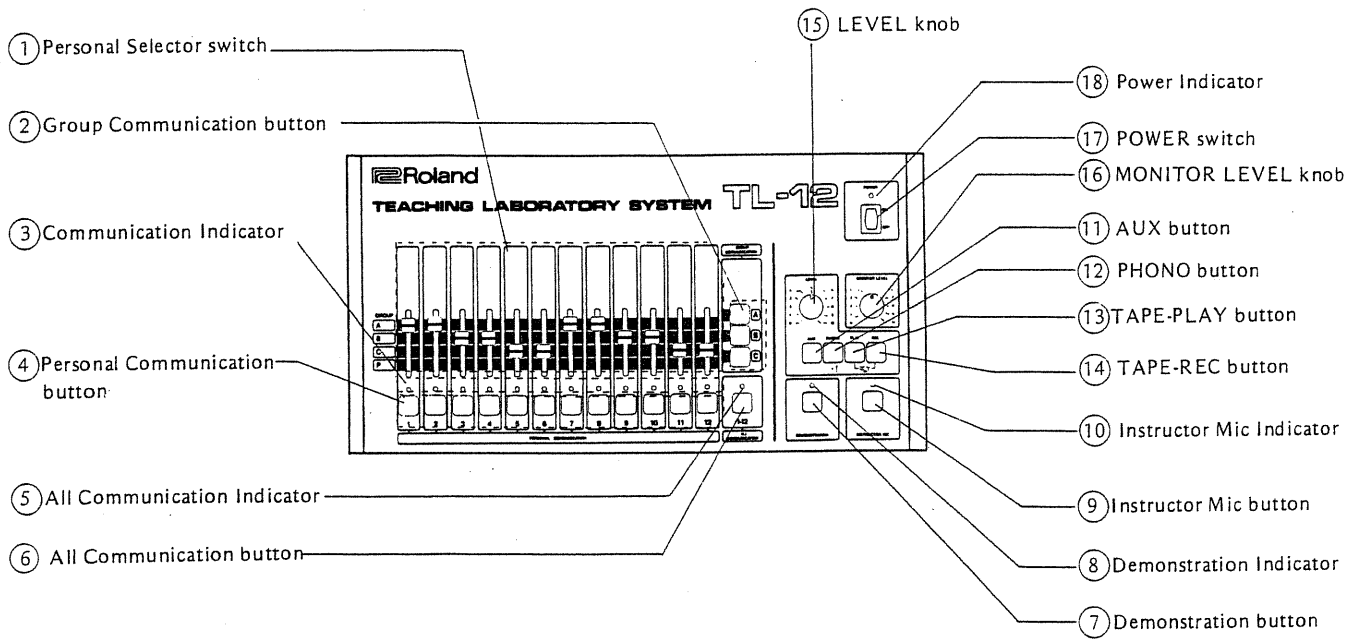

Connecting box < TLC-1 >

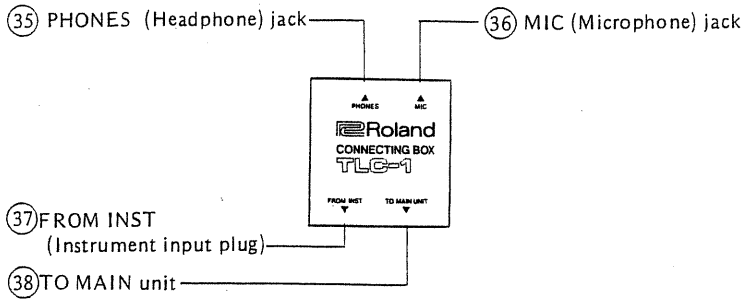

Head-Set < RHS-100 >

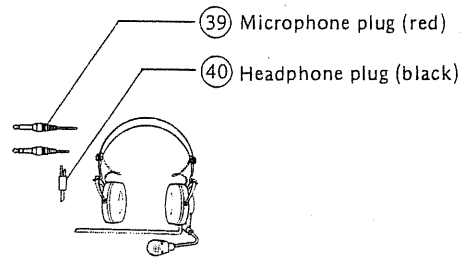

2. Connections

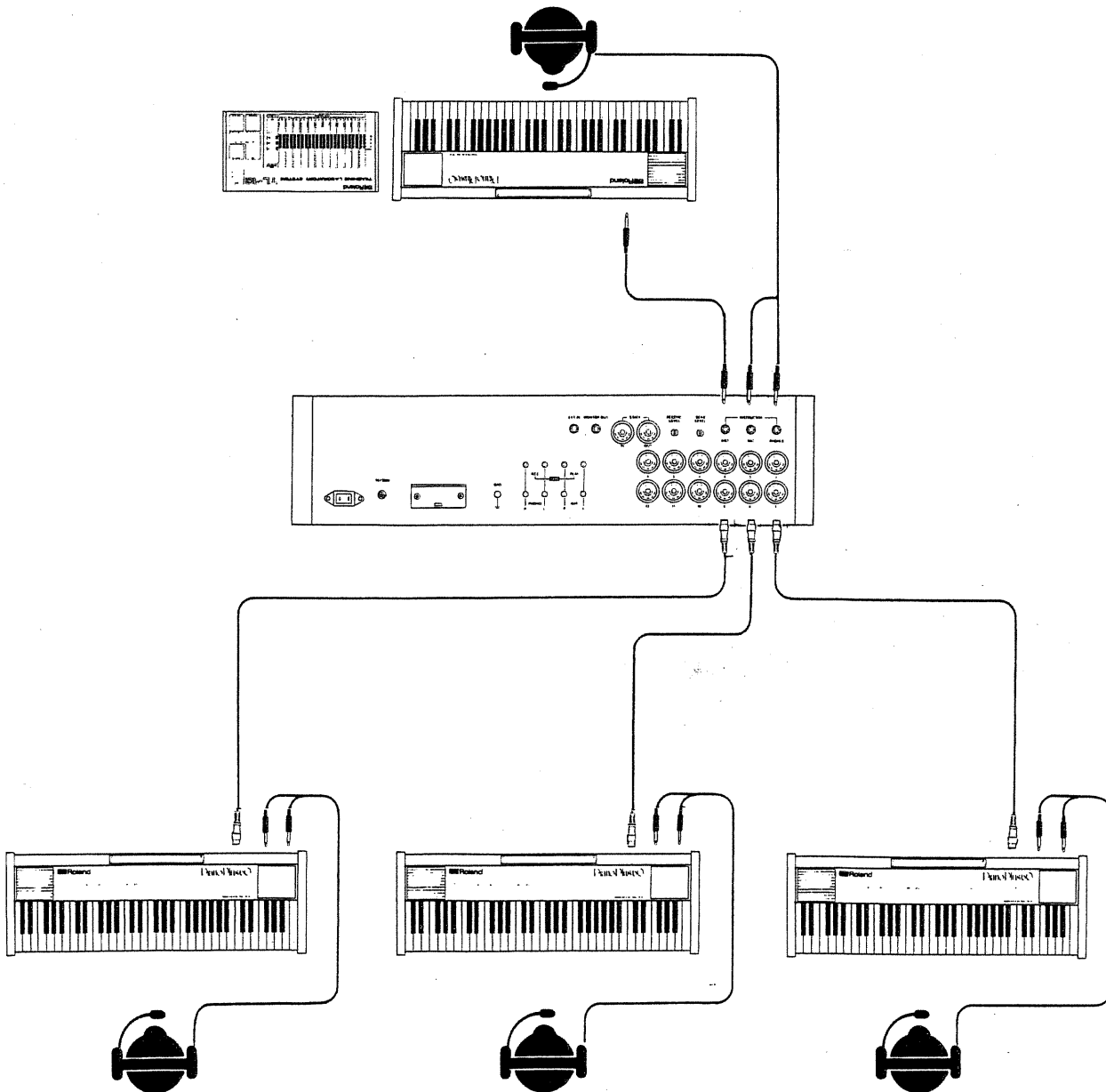

< Students >

- (1) Fix the Connecting box to the keyboard (back side) with the screws.
 - * If you cannot fix the Connecting box to the keyboard, fix it to the desk or elsewhere.
- (2) Connect the Head-set to the Connecting box.
- (3) Connect the Instrument input jack (37) to the keyboard. (*)
- (4) Connect the Connecting box to the Main Unit by using the DIN cord (5p). There are two types of DIN cords, T-5 (5m) and T-10 (10m).

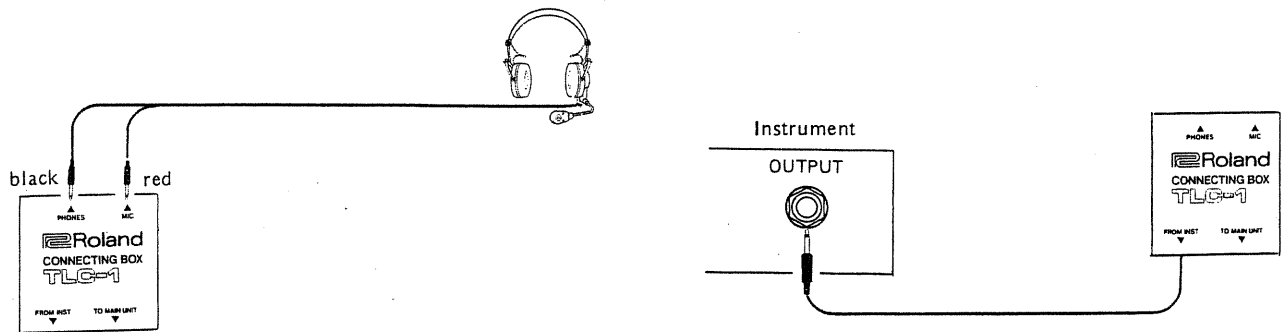

< Instructor >

- (1) Connect the Head-set to the Main unit.
- (2) Connect the output of the keyboard to the Main unit. (*)

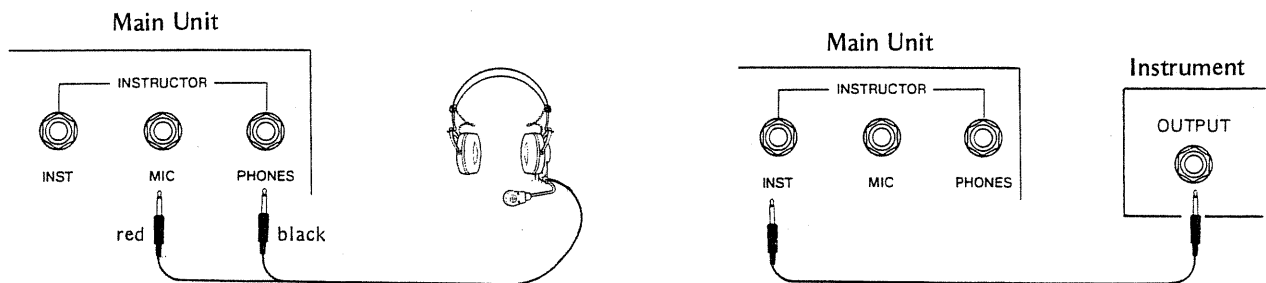

* If the keyboard includes the PHONES jack, use it for setting up.

★ The above is the set-up in the most basic combination.

3. Communications

There are 5 types of communications available.

- (1) Instructor ↔ The whole class
- (2) Instructor ↔ One individual student
- (3) Instructor ↔ Groups
- (4) Demonstration
- (5) Communication OFF

You can adjust the volume or set up the other external device simply by using the controls of the Main unit.

* You can turn your microphone on or off by pressing the Instructor Mic button (9). Press this button to turn it on (its indicator will light up) and press it again to turn it off.

(1) Instructor ↔ The whole class

If pressing the All Communication button (5), you can communicate with the whole class. In this case, communication between the students is not possible. This All Communication button (5) always works even if other buttons are being used.

* Press this button again to cancel this mode.

e.g. This mode is suitable:

when you wish to speak to the whole class or to give them your demonstration.

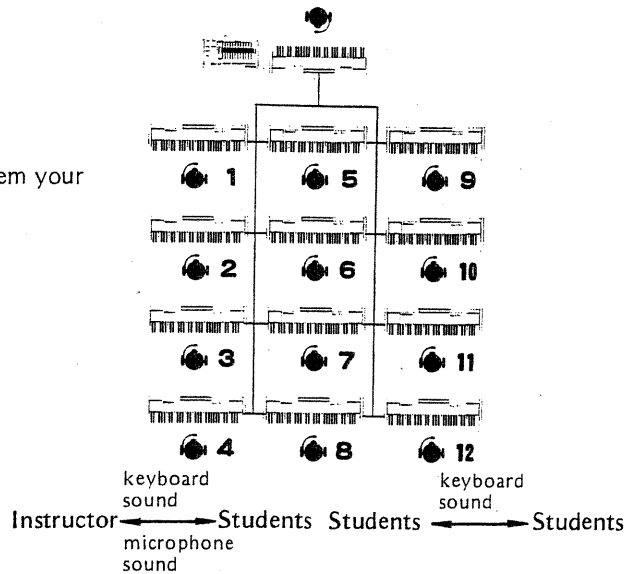
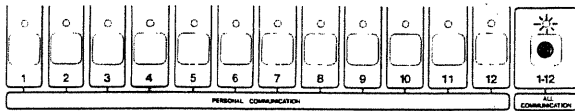

(2) Instructor ↔ Individual

This mode is to be taken when you wish to communicate with one particular student. For instance, if you wish to communicate with the student 4 individually, press the button 4 of the Personal Communication button (4), and its indicator lights up, then you can communicate with that student. It is possible to select two students at the same time, but they cannot hear each other's voice or keyboard sound through the headphones.

* This Personal Communication button (4) functions even if both this button and Group Communication button (2) are being used.

* Press the same button again and the communication with that student will be cut.

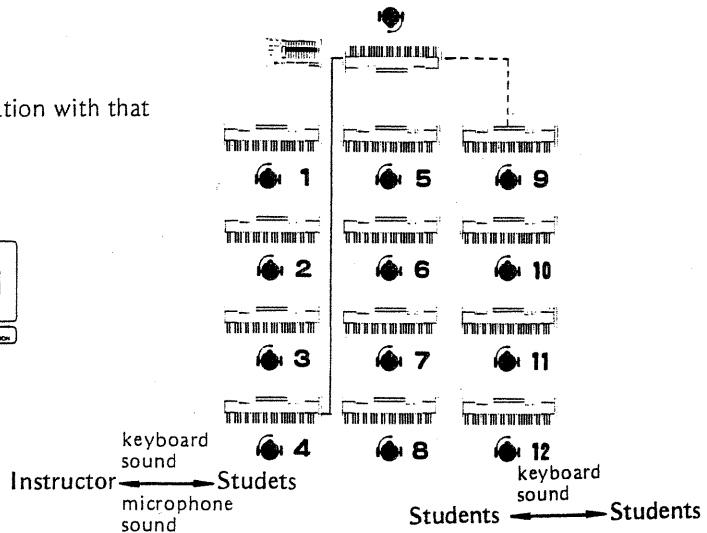
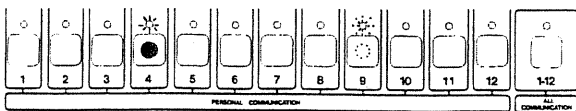

(3) Instructor ↔ Groups

You can divide the class into 3 groups by using the Personal Selector switch ①. Each group is completely separated from the other two groups, but a student can hear the microphone sounds or keyboard sounds of the other students within the same group.

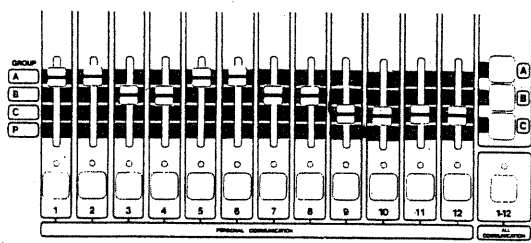

Group ← X → Group

Within a group/Student ← keyboard sound → Student
 microphone sound

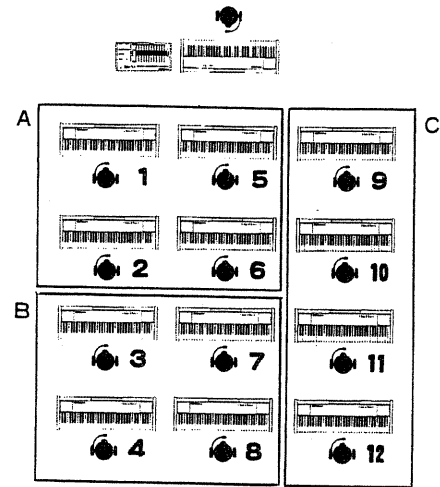

If you press the Group Communication button ②, the Communication Indicator ③ of the corresponding students will light up, then you can communicate with those students. You can simultaneously select 2 groups.

- * This Group Communication button ② have no effect in following cases.
 - When the All Communication button ⑤ is on.
 - When the Personal Communication button ④ is on.
 - When the Demonstration button ⑦ is on.

* Press this button again to cancel this mode.

e. g. This mode is suitable:

when you wish to communicate to one or two groups.

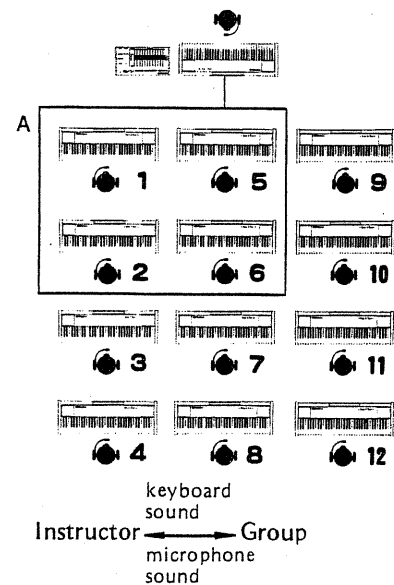
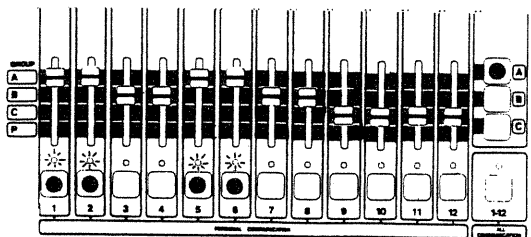

Instructor ← keyboard sound → Group
 microphone sound

(4) Demonstration

By using the Demonstration button (7), you can have the whole class listen to the demonstration of the selected student.

By pressing a Personal Communication button (4), select the student who is to give a demonstration. (His microphone sound will be cut.)

If you press only the Demonstration button (7) without pressing the Personal Communication button (4), your keyboard and microphone sound will be sent to the students.

* This Demonstration button (7) has no effect in the following cases.

- When the All Communication button (5) is on.
- When the Group Communication button (2) is on, but the Personal Communication button (4) is not pressed.

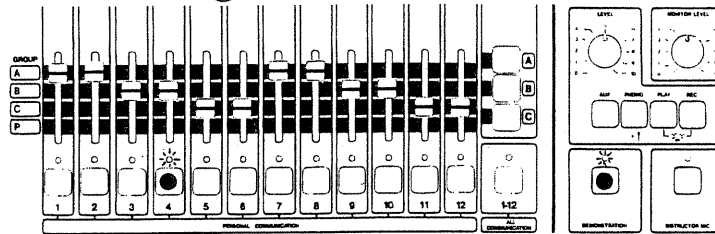

(5) Communication OFF

If you set the Personal Selector switch (1) to the 'Personal' position, the corresponding student will be isolated from any other student, therefore he can hear only his own sound through the headphones.

* If you wish to practice on your own, set all the Communication buttons to OFF, then no sound of yours is sent to the students.

e. g. This mode is most suitable:

- when the students should concentrate on their individual studies without hearing other student's sounds.
- when you wish the students to synthesize sounds or compose music.

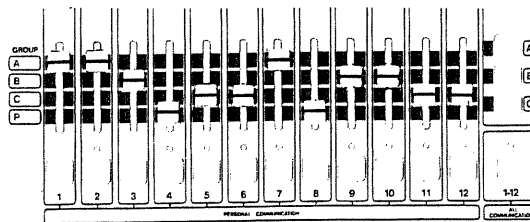

(6) Adjusting the Volume Levels

First of all, adjust the microphone sound from the students to the Instructor. It can be set to the comfortable level with the RECEIVE LEVEL 31, and that from the Instructor to the students can be adjusted with the SEND LEVEL (32).

* In this case, the volume of the keyboard also changes, but it cannot be controlled independent of the microphone volume. So it is necessary to adjust the keyboard volume with the volume knob of each keyboard. Set the microphone to the exact front of the mouth, or the comfortable level may not be obtained.

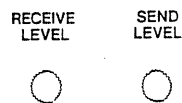

★ The above is the most basic operation procedures of TL-12.

4. Applications

By connecting external devices to the TL-12, various applications are available.

- (7) Connecting a Record-Player
- (8) Connecting a Tape-Recorder
- (9) Connecting a Rhythm Machine

The sound from those above can be sent to the student you have chosen in "3. Communications". Choose the most appropriate mode from (1) to (3) according to your aim.

Also, you can use a speaker by connecting the external amplifier to the MONITOR OUT jack ②④ of the TL-12.

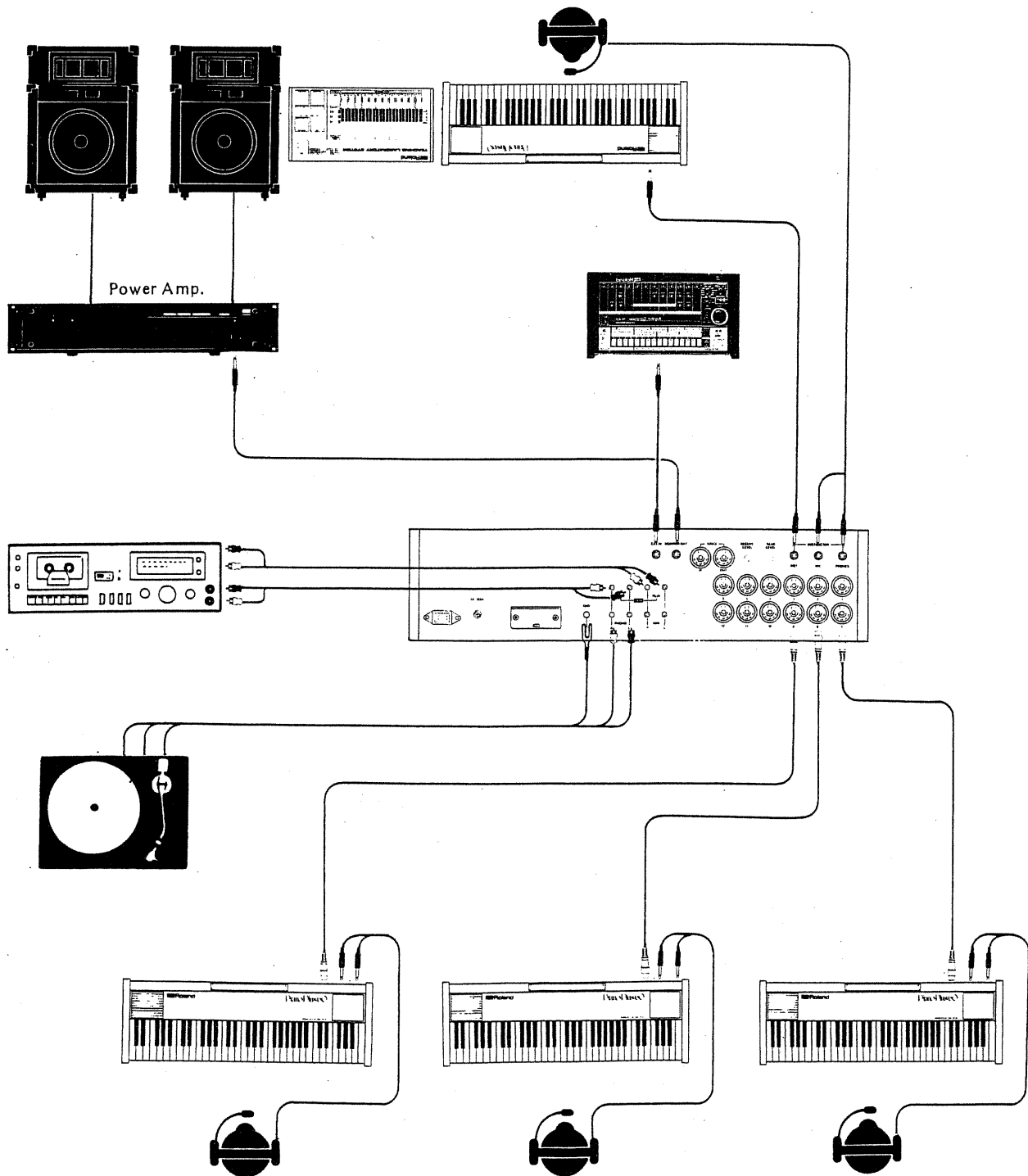

(7) **Connecting a Record-Player**

You can have the students listen to a record or play to the record.

1. Connect the record-player to PHONO jack (26) of the TL-12.
2. Press the PHONO button (12).

Adjust the volume by using the LEVEL knob (15).

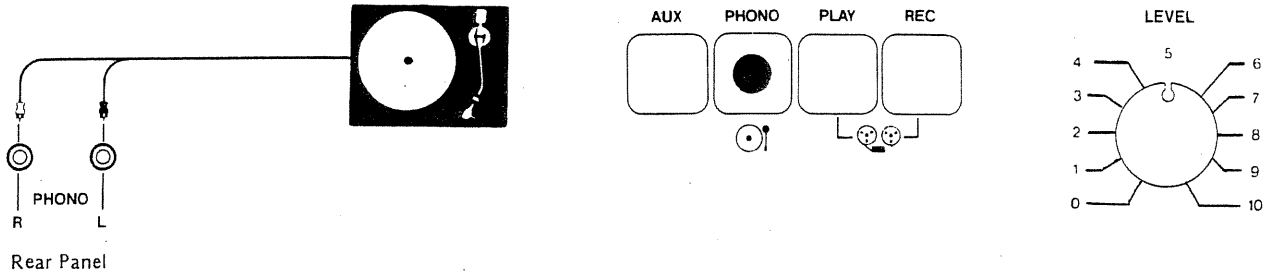

(8) **Connecting a Tape-Recorder**

You can have the students listen to the music tape or play to it.

Also, recording the students' performance is possible.

a) Playing back the tape

1. Connect the Line Out of the tape-recorder to the TAPE-PLAY jack (25) of the TL-12.
2. Press the TAPE-PLAY button (13) and set the tape-recorder to playing mode.

Adjust the volume with the LEVEL knob (15) of the TL-12 or output volume knob of the tape-recorder.

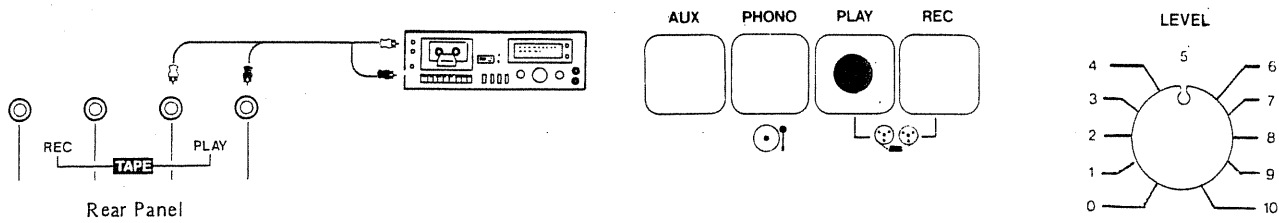

b) Recording

1. Connect the TAPE-REC jack (24) of the TL-12 to the Line In of the tape-recorder.

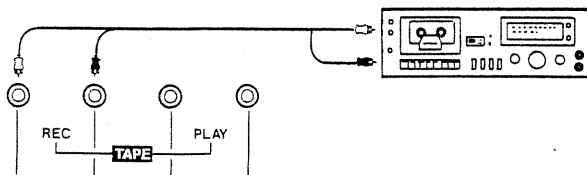

- Press the TAPE-REC button (14) and set the tape-recorder to the recording mode.

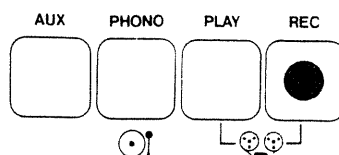

* When recording the instructor's sound

- (Its indicator will go out.) Press TAPE-REC button (14) to turn it on and press it again to turn it off.

The volume can be controlled with the recording level knob of the tape-recorder.

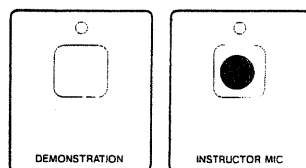

The TAPE-REC button (14) can be used together with the button (11), (12) and the EXT IN jack (29), thereby you can have the students play to the record or rhythm machine and also record it. For recording, however, two tape-recorders are required. Connect the tape-recorder for playing back to the AUX jack (27) and the other one for recording to the TAPE-REC jack (24).

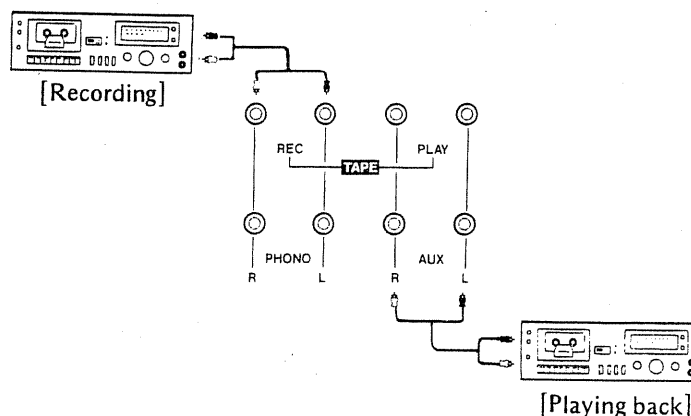

(9) Connecting a Rhythm Machine

You can add a certain rhythm to the students' performance or give the students rhythm lesson by using a rhythm machine as a Metronome. An electronic metronome can also be connected.

Connect the output of the Rhythm Machine to the EXT IN jack (29) of the TL-12.

EXT IN



A sound is heard from the unit connected to the EXT IN jack (29), regardless of the Front Panel setting of the TL-12. That is, unlike the other cases, you do not have to press the AUX or PHONO button.

The volume can be controlled with the volume knob of the unit used.

(10) Connecting the PA System

By connecting the PA system to the MONITOR OUT jack (28), the following sounds can be heard through the speaker. The volume can be controlled with the MONITOR LEVEL knob (16).

- **Student's keyboard sound**

You will hear the keyboard sound of the student selected with the Personal Communication button (4). His microphone sound is not heard.

- **Instructor's keyboard sound**

If the microphone sound is not necessary, press the Instructor Mic button (9) (It's indicator will go out).

- **Record**

Press the PHONO button (12).

- **Tape**

Press the TAPE-PLAY button (13).

- **External Device**

Press the AUX button (11), or connect the device to the EXT IN jack (29).



(11) Adding other Main Unit

Use the DIN connector (30) (IN, OUT) for the setting up the Main Units. Be sure to connect the output of the subordinate Main Unit to the input of the mother Main Unit (the one which the Instructor's Head-set and keyboard are connected to). Also, connect the external unit (such as a record-player) to the mother Main Unit.

When there are more than two Main Units, some buttons of the mother Main Unit activate those of the other Main Units (i. e. you only need to press the buttons of the mother Main Unit), but some buttons control only the mother Main Unit itself. (Refer to the table.) For instance, if you are to listen to the record, press the PHONO button (12) of mother Main Unit.

Also, each Main Unit independently divides 12 students into the groups A, B & C. In other words, the group A in the mother Main Unit consists of different members of the students from that in the other Main Unit.

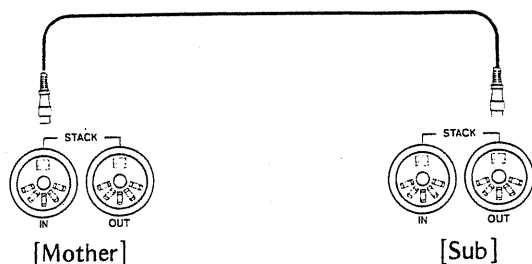

	Mother Main Unit	Sub Main Unit
① Personal Selector switch	○	○
② Group Communication button	○	○
④ Personal Communication button	○	○
⑤ All Communication button	○	
⑦ Demonstration button	○	○
⑨ Instructor Mic button	○	
⑪ AUX button	○	
⑫ PHONO button	○	
⑬ TAPE-PLAY button	○	
⑭ TAPE-REC button	○	
⑮ LEVEL knob	○	
⑯ MONITOR LEVEL knob	○	
⑳ TAPE REC jack	○	
㉑ TAPE PLAY jack	○	
㉒ PHONO jack	○	
㉓ AUX jack	○	
㉔ MONITOR OUT jack	○	
㉕ EXT IN jack	○	
㉖ RECEIVE LEVEL knob	○	
㉗ SEND LEVEL knob	○	

5. Functions

< TL-12 > Front Panel

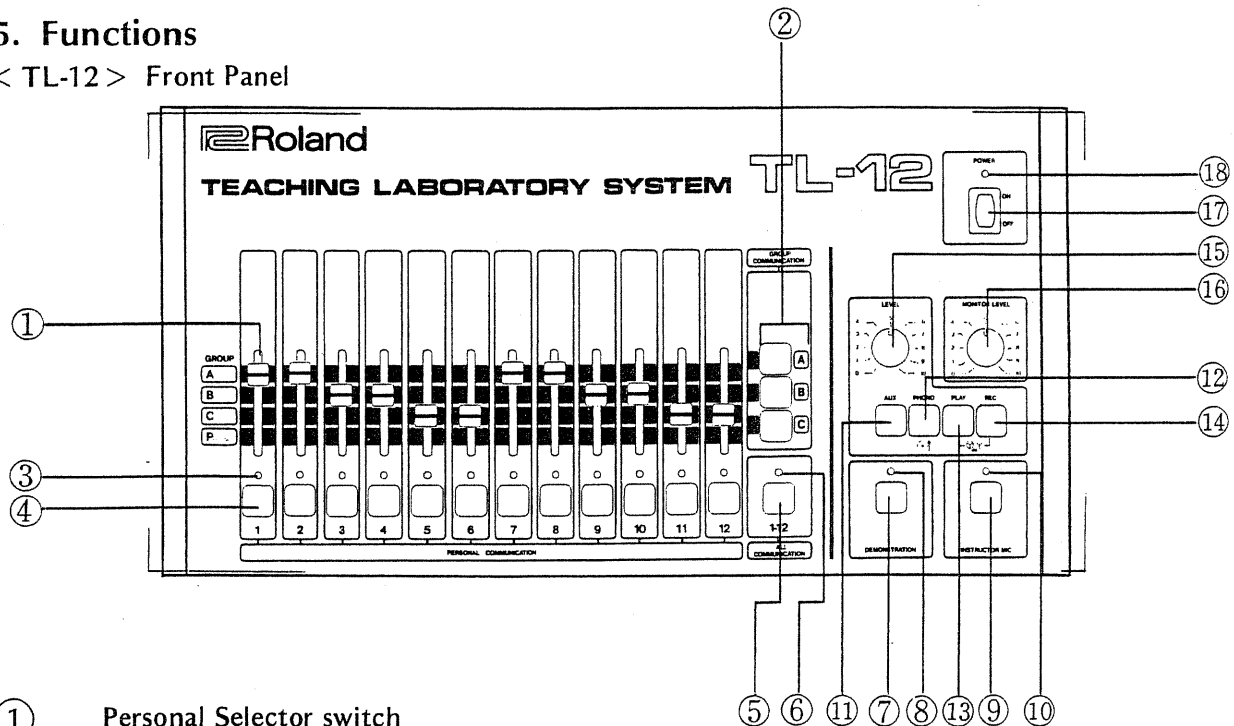

① Personal Selector switch

Each row of the switches includes A, B, C and Personal. These are used to divide the students into some groups. The student whose Personal Selector switch is set to the "Personal" position will be isolated from other students (unable to communicate with other students). (Refer to P. 9, 10)

② Group Communication button

When you wish to communicate with all the students within any of 3 groups A, B or C, press the button of that group. You may press two buttons at the same time.

* Press the button again to cancel this mode. (Refer to P. 9)

③ Communication Indicator

This indicator lights up when the Personal Communication button ④ is pressed, displaying what students are being communicated to.

④ Personal Communication button

If you wish to communicate to one particular student, press the appropriate button. You may press two buttons simultaneously.

* Press the button again to cancel the communication. (Refer to P. 8)

⑤ All Communication button

If you wish to communicate to all the students, simply press this button.

* Press the button again to cancel this mode. (Refer to P. 8)

⑥ All Communication Indicator

This indicator lights up when the All Communication button ⑤ is pressed.

⑦ Demonstration button

Press this button when all the class listen to the performance of a certain student. (Refer to P. 10)

⑧ Demonstration Indicator

This indicator lights up when the Demonstration button ⑦ is pressed.

⑨ Instructor Mic button

Your microphone can be turned on or off by pressing this button.

- ⑩ **Instructor Mic Indicator**
- ⑪ **AUX button**
Press this button when using other kind of audio system. (Refer to P. 10)
- ⑫ **PHONO button**
Press this button when using a record-player. (Refer to P. 10)
- ⑬ **TAPE-PLAY button**
Press this button when using a tape-recorder. (Refer to P. 10)
- ⑭ **TAPE-REC button**
Press this button when recording the students' performance, etc. (Refer to P. 10)
- ⑮ **LEVEL knob**
This knob is used to adjust the volume when you use an external unit such as a record-player.
- ⑯ **MONITOR LEVEL knob**
This knob is to adjust the volume when you are listening to the sound of the external unit such as a record-player or tape-recorder through the speaker.

- ⑰ **POWER switch**
- ⑱ **Power Indicator**

Rear Panel

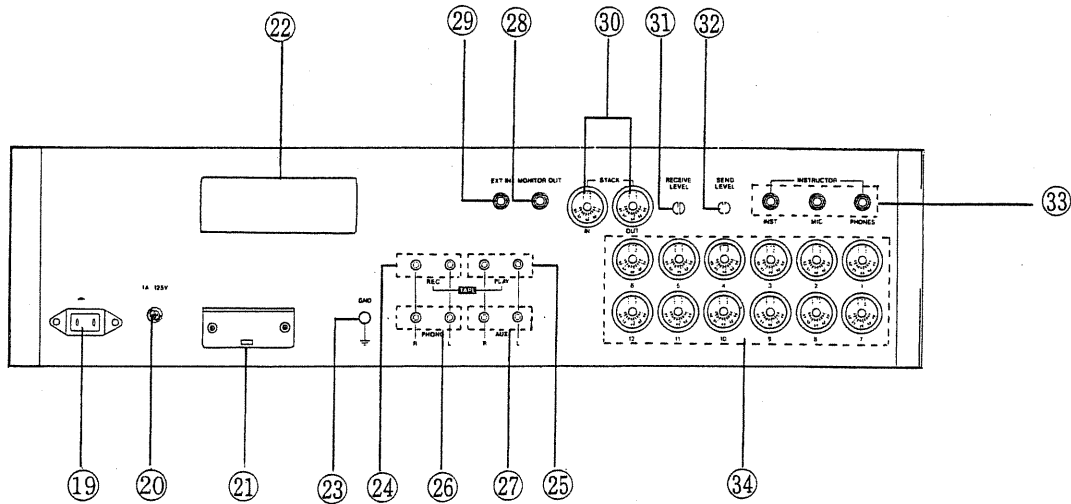

- ⑲ **AC INLET jack**
- ⑳ **Fuse Holder**
- ㉑ **Voltage Converter (Voltage Selector switch)**
- ㉒ **Name Plate**
- ㉓ **GND (earth jack)**
- ㉔ **TAPE-REC jack**
Connect this to the Line In of the tape-recorder. (Refer to P. 10)

②5 **TAPE-PLAY jack.**

Connect the Line Out of the tape-recorder to. (Refer to P. 10)

②6 **PHONO jack**

Connect the record-player to this jack. (Refer to P. 10)

②7 **AUX jack**

Connect the output of the other type of the audio system to. (Refer to P. 10)

②8 **MONITOR OUT jack**

The following sound can be heard by connecting this jack to the speaker.

- Student's keyboard sound
- Instructor's keyboard sound (+ his microphone sound)
- Record
- Tape
- External Device

Adjust the volume with the MONITOR LEVEL knob ①6. (Refer to P. 14)

②9 **EXT IN jack**

This jack is to connect the Rhythm Machine, electronic metronome, etc. (Refer to P. 10)

③0 **DIN connector (for stacking)**

- IN
- OUT

This is used to add more Main Units.

③1 **RECEIVE LEVEL knob**

This is to adjust the students' microphone and the keyboard volume level.

③2 **SEND LEVEL knob**

This is to adjust the Instructor's microphone and keyboard volume level.

③3 **INSTRUCTOR'S Connection jacks**

- INST (instrument) jack

Connect the output of the Instructor's keyboard to this jack.

- MIC (microphone) jack (red washer)

Connect the Mic plug of the Instructor's head-set to this jack.

- PHONES (headphone) jack (black washer)

Connect the headphone plug of the Instructor's head-set.

③4 **DIN connector**

These are to connect each Connecting box TLC-1 to the Main Unit. There are 12 connectors, one for each student.

Connecting Box < TLC-1 >

③5 **PHONES (headphones) jack (black washer)**

This is to connect the headphone plug of the student's head-set.

③6 **MIC (microphone) jack (red washer)**

This is to connect the microphone plug of the student's head-set.

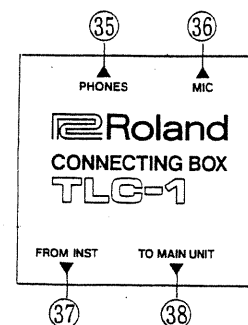

- ③⑦ **FROM INST jack**
Connect this jack to the output of the student's keyboard.
- ③⑧ **TO MAIN UNIT jack**
Connect this jack to the Main Unit by using a DIN cord.

Head Set < RHS-100 >

- ③⑨ **Microphone plug (red)**
Connect this plug to the MIC jack ③⑥ of the TLC-1.
- ④① **Headphone plug (black)**
Connect this plug to the PHONES jack ③⑤ of the TLC-1.

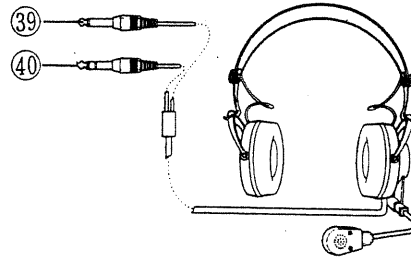

Specifications

< TL-12 >

- **Students:** 12
- **Controls:**
 - Personal Selector switch x 12
 - Group Communication button x 3
 - Personal Communication button x 12
 - All Communication button x 1
 - Demonstration button x 1
 - Instructor Mic button x 1
- **External Input/Output Selector buttons:**
 - AUX button x 1
 - PHONO button x 1
 - TAPE-PLAY button x 1
 - TAPE-REC button x 1
 - LEVEL knob x 1
 - MONITOR LEVEL knob x 1
 - POWER switch x 1
- **Indicators:**
 - Communication Indicator x 12
 - All Communication Indicator x 1
 - Demonstration Indicator x 1
 - Instructor Mic Indicator x 1
 - Power Indicator x 1
- **External Input/Output jacks:**
 - DIN connector (for student); DIN 5P x 12
 - DIN connector (for stacking); DIN 5P
 - IN x 1
 - OUT x 1
 - INSTRUCTOR's connection jacks
 - INST (instrument);
(Standard 1/4 phone jack, -10dBm, over 50 kΩ) x 1
 - MIC (microphone);
(Standard 1/4 phone jack, -60dBm, over 10 kΩ) x 1
 - PHONES (headphones);
(Standard 1/4 phone jack, over 16Ω) x 1

- TAPE PLAY jack;
(RCA pin jack, -10dBm, over 20kΩ) x 2
- TAPE REC jack;
(RCA pin jack, -10dBm, under 1kΩ) x 2
- PHONO jack;
(RCA pin jack, 5mV, 47kΩ, RIAA) x 2
- AUX jack;
(RCA pin jack, -10dBm, over 50kΩ) x 2
- MONITOR OUT jack;
(Standard 1/4 phone jack, -10dBm, under 1kΩ) x 1
- EXT IN jack;
(Standard 1/4 phone jack, -10dBm, over 50kΩ) x 1
- Others:
 - RECEIVE LEVEL knob x 1
 - SEND LEVEL knob x 1
 - GND x 1
 - AC Inlet x 1
 - Fuse Holder x 1
- Power Consumption:
This is shown on the Name Plate of the TL-12.
- Dimensions: 456(W) x 300(D) x 116(H) mm
17-15/16(W) x 11-13/16(D) x 4-9/16(H) inch.
- Weight: 4.3 kg
9 lb. 8 oz.

< TLC-1 >

- Dimensions: 69(W) x 50(D) x 32(H) mm
2-3/4(W) x 1-15/16(D) x 1-1/4(H) inch.

Accessories

- Connection cord
 - Instrument ↔ TL-12 x 1
 - for stacking (DIN5P) x 1

Specifications are subject to change without notice.

Options

- Connecting box (TLC-1)
- Head-set (RHS-100)
- T-5 (DIN5P, 5m)
- T-10 (DIN5P, 10m)

