

BOSS

DM-3 Delay INSTRUCTIONS

DM-3 allows continuous control of the delay time from 20 to 300ms. Also, it enjoys high quality sound owing to its noise reduction circuits.



- Please read the instructions carefully for proper operating procedures of the BOSS DM-3.

RADIO AND TELEVISION INTERFERENCE

Warning – This equipment has been verified to comply with the limits for a Class B computing device, pursuant to Subpart J, of Part 15, of FCC rules. Operation with non-certified or non-verified equipment is likely to result in interference to radio and TV reception."

The equipment described in this manual generates and uses radio-frequency energy. If it is not installed and used properly, that is, in strict accordance with our instructions, it may cause interference with radio and television reception.

This equipment has been tested and found to comply with the limits for a Class B computing device in accordance with the specifications in Subpart J, of Part 15, of FCC Rules. These rules are designed to provide reasonable protection against such interference in a residential installation. However, there is no guarantee that the interference will not occur in a particular installation. If this equipment does cause interference to radio or television reception, which can be determined by turning the equipment on and off, the user is encouraged to try to correct the interference by the following measure:

- Disconnect other devices and their input/output cables one at a time. If the interference stops, it is caused by either the other device or its I/O cable.

These devices usually require Roland designated shielded I/O cables. For Roland devices, you can obtain the proper shielded cable from your dealer. For non Roland devices, contact the manufacturer or dealer for assistance.

If your equipment does cause interference to radio or television reception, you can try to correct the interference by using one or more of the following measures:

- Turn the TV or radio antenna until the interference stops.
- Move the equipment to one side or the other of the TV or radio.
- Move the equipment farther away from the TV or radio.
- Plug the equipment into an outlet that is on a different circuit than the TV or radio. (That is, make certain the equipment and the radio or television set are on circuits controlled by different circuit breakers or fuses.)
- Consider installing a rooftop television antenna with coaxial cable lead-in between the antenna and TV.

If necessary, you should consult your dealer or an experienced radio/television technician for additional suggestions. You may find helpful the following booklet prepared by the Federal Communications Commission:

"How to Identify and Resolve Radio-TV Interference Problems"

This booklet is available from the U.S. Government Printing Office, Washington, D.C., 20402, Stock No. 004-000-00345-4.

PANEL DESCRIPTION

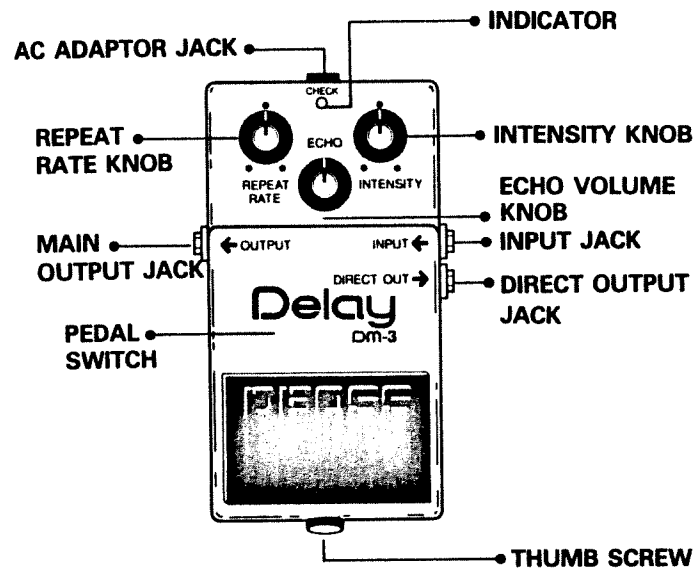

REPEAT RATE KNOB

This knob controls the repetition rate of the echoes.

INTENSITY KNOB

This knob decides the number of returning echoes. Turning this clockwise increases the number, and in its fully counterclockwise position, single delay is obtained.

ECHO VOLUME KNOB

This knob sets the output level of echo. Turning it clockwise increases the level of the delay sound, and at its fully counterclockwise position, normal sound is heard.

AC ADAPTOR JACK

Connect a BOSS AC Adaptor to this jack for proper AC operation.

INPUT JACK

Connect an instrument such as an electric guitar or other electronic musical instrument.

INDICATOR

This indicator lights up when the unit is turned on. This also serves as battery check, when the battery is flat, this indicator fails to light or lights dimmer than usual.

MAIN OUTPUT JACK

Through this jack, mixed signal of direct and delay sounds is sent out. If, however, the Direct Output Jack is used at the same time, merely delay sound will be output here.

DIRECT OUTPUT JACK

Through this jack, direct sound is sent out.

PEDAL SWITCH

Adopting FET switching system, this pedal switch is free from audible click or pop.

THUMB SCREW

Unscrew this to open the unit for battery replacement

OPERATION

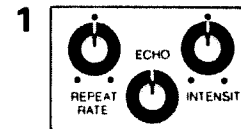

1 After hook-up is completed, set the controls as shown left.

- 2 Press the Pedal Switch. If the indicator lights up, the effect is on, and if not, effect is off.
*This indicator also serves as battery check. If it becomes dimmer or does not light at all, battery replacement is required.
- 3 Set the Repeat Rate Knob to proper position.
- 4 Adjust the repetition number by rotating the Intensity Knob to proper position. As you rotate this knob clockwise, the number is increased, and at a certain position, oscillation will occur.
- 5 Adjust the level of the delay sound with the Echo Volume Knob. At its fully clockwise position, delay and direct sounds are equal in volume. When both output jacks are in use, with this knob set to fully counterclockwise, there is no output through the Main Output Jack.

CONNECTION

*Avoid using the DM-3 in extreme heat, humidity or where it may be affected by dust.

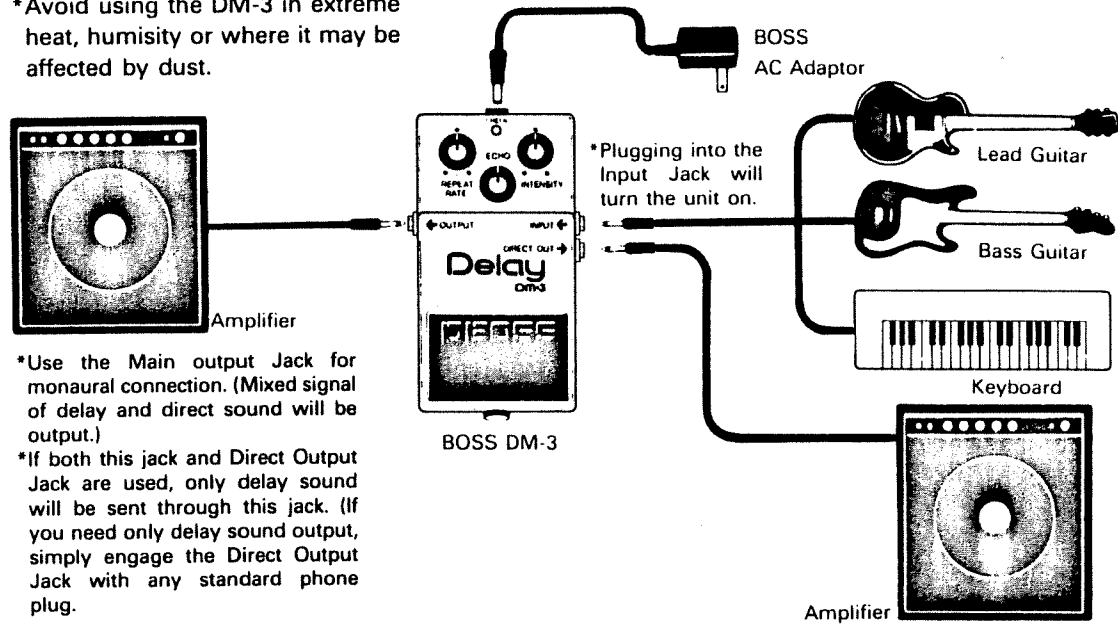

*Use the Main output Jack for monaural connection. (Mixed signal of delay and direct sound will be output.)

*If both this jack and Direct Output Jack are used, only delay sound will be sent through this jack. (If you need only delay sound output, simply engage the Direct Output Jack with any standard phone plug.)

*If the unit is not to be used, be sure to disconnect the cable from the Input Jack.

CAUTIONS FOR REPLACING AND HANDLING BATTERY

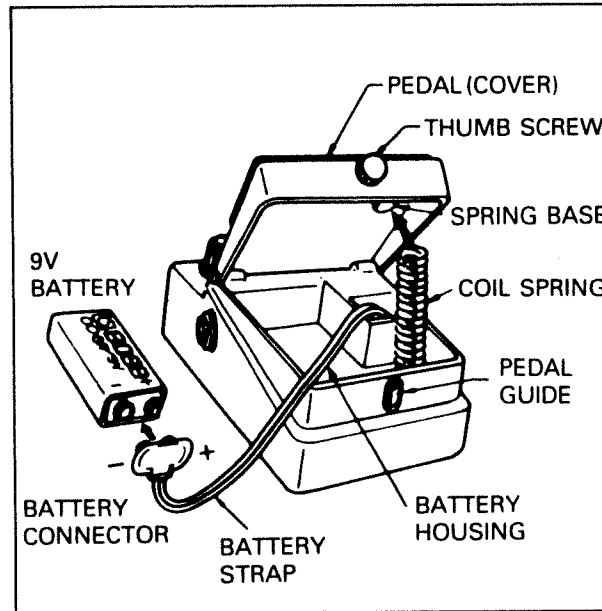

BATTERY REPLACEMENT USE 9V BATTERY

- Loosen the screw and open the Pedal.
- Take out the battery from the Battery Housing and pull up the Battery Strap.
- Replace with a new battery.
- Put the Coil Spring to the Spring Base and close the Pedal.
- Firmly tighten the screw.
- * Make sure that the Battery Strap is not caught in the Pedal or Coil Spring.

PRECAUTIONS

- When the DM-3 is not in use for a long period, remove the battery to prevent the trouble caused by the battery leakage.
 - If the battery voltage drops, effect becomes inferior or no sound is produced. To prevent that, replace the battery.
 - For proper AC operation, be sure to use a BOSS ACA-120, 220 or 240 depending on the voltage system in your country.
- Be sure to keep the battery securely connected even while using the AC Adaptor, then the DM-3 will continued to operate even if the AC Adaptor cord comes out during performance.
 - Unplug the cord from the INPUT jack when the DM-3 is not in use to avoid battery waste.

AC ADAPTOR (OPTION)

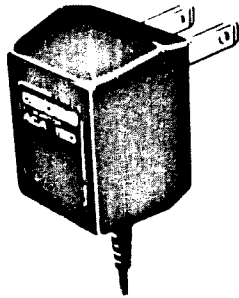

BOSS ACA-120
FOR 117V AC

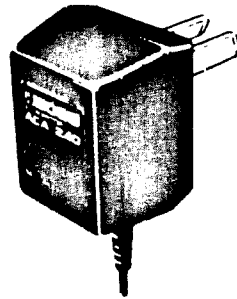

BOSS ACA-240
FOR 240V AC

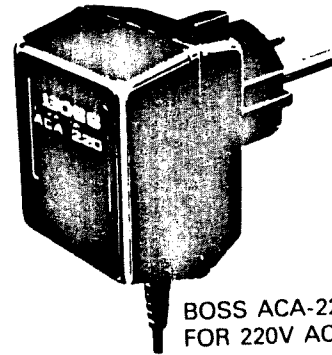

BOSS ACA-220
FOR 220V AC

UPC 10126



10901

SPECIFICATIONS

- Power 9V Dry Battery, AC Adaptor (optional BOSS ACA-120, 220 or 240)
- Consumption 9V DC/15mA
- Controls REPEAT RATE, INTENSITY, ECHO Volume
- Others Normal/Effect Selector Switch (FET),
Indicator (for Effect On/Off and Battery Check)
- Jacks Input, Direct Output, Main Output, AC Adaptor
- Delay Time 20 to 300ms
- Residual Noise Below -100dBm (IHF-A)
- Input Impedance 1MΩ
- Output Load Impedance Over 10kΩ
- Dimensions 70(W) × 55(H) × 125(D)mm / 2³/₄(W) × 2³/₁₆(H) × 4¹⁵/₁₆(D)in.
- Weight 450g/1lb

*Specifications are subject to change without notice.



Products of Roland