

# Roland®

DIGITAL INTERFACE FOR ADAT/DA-88/RS-422

---

# DIF-800

## Owner's Manual

Before using this unit, carefully read the sections entitled: "USING THE UNIT SAFELY" and "IMPORTANT NOTES" (p. 2 ; p. 5). These sections provide important information concerning the proper operation of the unit. The manual should be saved and kept on hand as a convenient reference.

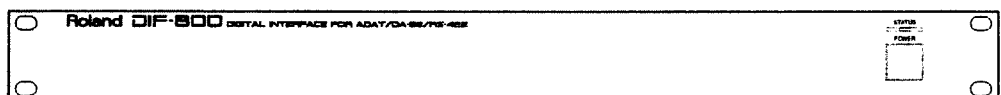

# USING THE UNIT SAFELY

## INSTRUCTIONS FOR THE PREVENTION OF FIRE, ELECTRIC SHOCK, OR INJURY TO PERSONS

### About ⚠ WARNING and ⚠ CAUTION Notices

<b>⚠ WARNING</b>	Used for instructions intended to alert the user to the risk of death or severe injury should the unit be used improperly.
<b>⚠ CAUTION</b>	Used for instructions intended to alert the user to the risk of injury or material damage should the unit be used improperly. * Material damage refers to damage or other adverse effects caused with respect to the home and all its furnishings, as well to domestic animals or pets.

### About the Symbols

	The ⚠ symbol alerts the user to important instructions or warnings. The specific meaning of the symbol is determined by the design contained within the triangle. In the case of the symbol at left, it is used for general cautions, warnings, or alerts to danger.
	The ⚡ symbol alerts the user to items that must never be carried out (are forbidden). The specific thing that must not be done is indicated by the design contained within the circle. In the case of the symbol at left, it means that the unit must never be disassembled.
	The ⚡ symbol alerts the user to things that must be carried out. The specific thing that must be done is indicated by the design contained within the circle. In the case of the symbol at left, it means that the power-cord plug must be unplugged from the outlet.

### ALWAYS OBSERVE THE FOLLOWING

<b>⚠ WARNING</b>	
• Before using this unit, make sure to read the instructions below, and the Owner's Manual.	
• Do not open (or modify in any way) the unit or its AC adaptor.	
• Do not attempt to repair the unit, or replace parts within it (except when this manual provides specific instructions directing you to do so). Refer all servicing to your dealer, or qualified Roland service personnel.	
• Never use or store the unit in places that are: <ul style="list-style-type: none"> <li>• Subject to temperature extremes (e.g., direct sunlight in an enclosed vehicle, near a heating duct, on top of heat-generating equipment); or are</li> <li>• Damp (e.g., baths, washrooms, on wet floors); or are</li> <li>• Humid; or are</li> <li>• Dusty; or are</li> <li>• Subject to high levels of vibration.</li> </ul>	
• This unit should be used only with a rack or stand that is recommended by Roland.	
• When using the unit with a rack or stand recommended by Roland, the rack or stand must be carefully placed so it is level and sure to remain stable. If not using a rack or stand, you still need to make sure that any location you choose for placing the unit provides a level surface that will properly support the unit, and keep it from wobbling.	
• Be sure to use only the AC adaptor supplied with the unit. Also, make sure the line voltage at the installation matches the input voltage specified on the AC adaptor's body. Other AC adaptors may use a different polarity, or be designed for a different voltage, so their use could result in damage, malfunction, or electric shock.	

<b>⚠ WARNING</b>	
• Avoid damaging the power cord. Do not bend it excessively, step on it, place heavy objects on it, etc. A damaged cord can easily become a shock or fire hazard. Never use a power cord after it has been damaged.	
• Do not allow any objects (e.g., flammable material, coins, pins); or liquids of any kind (water, soft drinks, etc.) to penetrate the unit.	
• Immediately turn the power off, remove the AC adaptor from the outlet, and request servicing by your dealer or qualified Roland service personnel when: <ul style="list-style-type: none"> <li>• The AC adaptor or the power-supply cord has been damaged; or</li> <li>• Objects have fallen into, or liquid has been spilled onto the unit; or</li> <li>• The unit has been exposed to rain (or otherwise has become wet); or</li> <li>• The unit does not appear to operate normally or exhibits a marked change in performance.</li> </ul>	
• In households with small children, an adult should provide supervision until the child is capable of following all the rules essential for the safe operation of the unit.	
• Protect the unit from strong impact. (Do not drop it!)	
• Do not force the unit's power-supply cord to share an outlet with an unreasonable number of other devices. Be especially careful when using extension cords—the total power used by all devices you have connected to the extension cord's outlet must never exceed the power rating (watts/amperes) for the extension cord. Excessive loads can cause the insulation on the cord to heat up and eventually melt through.	
• Before using the unit in a foreign country, consult with your dealer, or qualified Roland service personnel.	

# Read this first!

In order to use the DIF-800, you must have a Roland DM-800 Multi-track Disk Recorder.  
(The DIF-800 will not operate without a DM-800.)

Please use a DM-800 with an operating system version is 2.00 or later. If your DM-800 has an operating system of an earlier version, have the software upgraded.

For a software upgrade, contact a nearby Roland service center.

## ■ Checking the DM-800 software version .....

You can check the software version of your DM-800 in the following two ways.

### ● After the DM-800 power is turned on

When the DM-800 is turned on, the software version is displayed in the lower right of the opening screen.

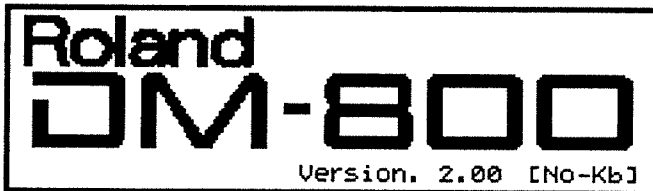





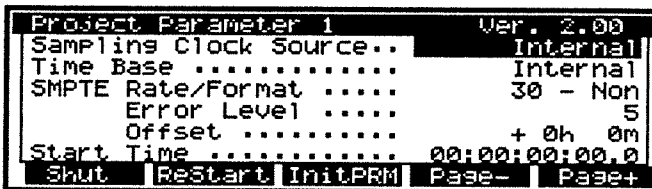



### ● System screen

In System mode, the software version is displayed in the upper right of the LCD display.





**⚠ CAUTION**

- The unit and the AC adaptor should be located so their location or position does not interfere with their proper ventilation. 
- Always grasp only the plug or the body of the AC adaptor when plugging into, or unplugging from, an outlet or this unit. 
- Whenever the unit is to remain unused for an extended period of time, disconnect the AC adaptor. 
- Try to prevent cords and cables from becoming entangled. Also, all cords and cables should be placed so they are out of the reach of children. 
- Never climb on top of, nor place heavy objects on the unit. 
- Never handle the AC adaptor body, or its plugs, with wet hands when plugging into, or unplugging from, an outlet or this unit. 
- Before moving the unit, disconnect the AC adaptor and all cords coming from external devices. 
- Before cleaning the unit, turn off the power and unplug the AC adaptor from the outlet (p. 5). 
- Whenever you suspect the possibility of lightning in your area, disconnect the AC adaptor from the outlet. 

---

## Introduction

Thank you for purchasing the Roland DIF-800 Digital Interface.

The DIF-800 is an interface unit that makes possible the synchronous operation of the DM-800 and an ADAT, DA-88, or an RS-422 compatible video device, and allows up to 8 channels of digital audio to be exchanged between the DM-800 and an ADAT or DA-88.

In order to take full advantage of the functionality of the DIF-800, please read this manual carefully.

**ADAT is a registered trademark of the Alesis Corporation.**

**All product names mentioned in this document are trademarks or registered trademarks of their respective owners.**

## Features

- Up to 8 channels of digital audio can be digitally recorded between the DM-800 and a tape-based multitrack recorder, such as the Alesis ADAT or the Tascam DA-88.
- A tape-based digital multitrack recorder such as the Alesis ADAT or the Tascam DA-88 can be synchronized with the DM-800.
- An RS-422 compatible video device can be used to control the DM-800.

---

## Contents

<b>IMPORTANT NOTES</b> .....	<b>5</b>
<b>Front and Rear Panels</b> .....	<b>6</b>
<b>Connections</b> .....	<b>8</b>
Connecting a DM-800 and an ADAT.....	8
Connecting a DM-800 and a DA-88 (RC-848).....	9
Connecting a DM-800 and a VTR.....	10
<b>Turning the power on/off</b> .....	<b>11</b>
<b>DM-800 Parameter Settings</b> .....	<b>12</b>
<b>Operation</b> .....	<b>14</b>
Setups with a DM-800 and ADAT .....	14
Setups with a DM-800 and DA-88 (RC-848).....	16
Setups with a DM-800 and video device.....	18
<b>Audio signal section block diagram</b> .....	<b>19</b>
<b>Specifications</b> .....	<b>20</b>
<b>Information</b> .....	<b>21</b>

---

Copyright © 1995 ROLAND CORPORATION

All rights reserved. No part of this publication may be reproduced in any form without the written permission of ROLAND CORPORATION.

# IMPORTANT NOTES

In addition to the items listed under "USING THE UNIT SAFELY" on page 2—3 , please read and observe the following:

## Power Supply

- Do not use this unit on the same power circuit with any device that will generate line noise (such as an electric motor or variable lighting system).
- The AC adaptor will begin to generate heat after long hours of consecutive use. This is normal, and is not a cause for concern.
- Before connecting this unit to other devices, turn off the power to all units. This will help prevent malfunctions and/or damage to speakers or other devices.

## Placement

- This device may interfere with radio and television reception. Do not use this device in the vicinity of such receivers.
- Do not expose the unit to direct sunlight, place it near devices that radiate heat, leave it inside an enclosed vehicle, or otherwise subject it to temperature extremes. Excessive heat can deform or discolor the unit.

## Maintenance

- For everyday cleaning wipe the unit with a soft, dry cloth or one that has been slightly dampened with water. To remove stubborn dirt, use a mild, non-abrasive detergent. Afterwards, be sure to wipe the unit thoroughly with a soft, dry cloth.
- Never use benzene, thinners, alcohol or solvents of any kind, to avoid the possibility of discoloration and/or deformation.

## Additional Precautions

- Use a reasonable amount of care when using the unit's buttons, sliders, or other controls; and when using its jacks and connectors. Rough handling can lead to malfunctions.
- When connecting / disconnecting all cables, grasp the connector itself—never pull on the cable. This way you will avoid causing shorts, or damage to the cable's internal elements.
- To avoid disturbing your neighbors, try to keep the unit's volume at reasonable levels (especially when it is late at night).
- When you need to transport the unit, package it in the box (including padding) that it came in, if possible. Otherwise, you will need to use equivalent packaging materials.

# Front and Rear Panels

## Front Panel

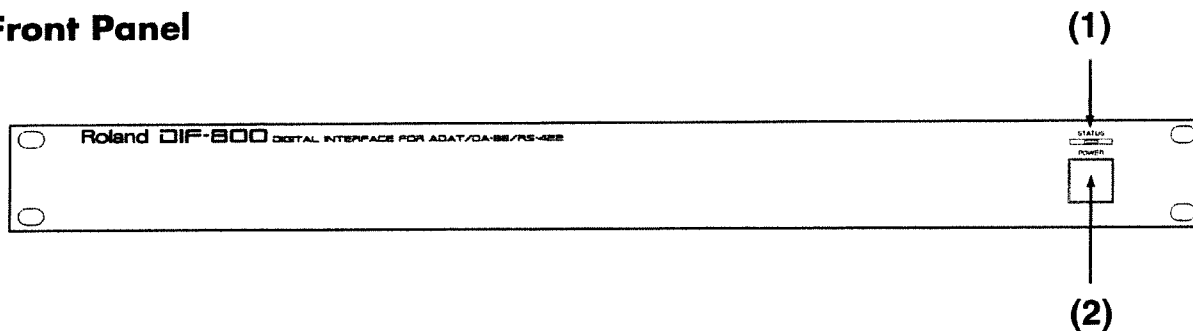

## Rear Panel

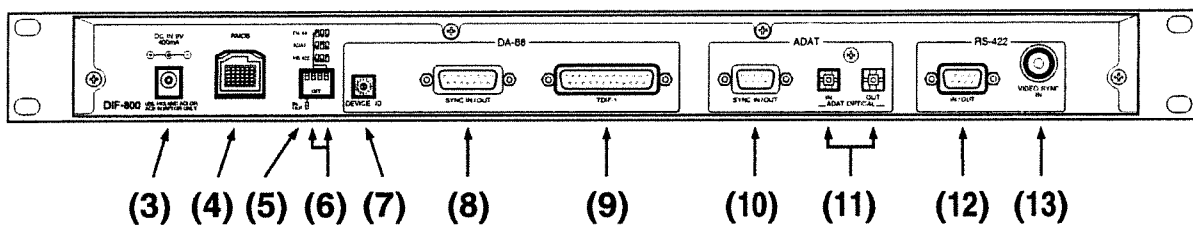

### 1. Status Indicator

This indicates the operational status of the DIF-800 and the command transmission/reception status.

Normally this will be lit green. While a command from the DM-800 is being transmitted or received, it will blink orange. If an error occurs, it will blink red.

#### Note:

If the equipment connected to the DIF-800 is turned on, the indicator may light orange even after the DIF-800 power is turned off, but this is not a malfunction.

### 2. Power Switch

### 3. AC Adapter Jack

Connect the included AC adapter here.

### 4. RMDB Connector

This transmits control commands and synchronization signals between the DIF-800 and the DM-800, and performs input/output of 8 channels of digital audio. Use the included RMDB cable.

### Mode DIP Switches

These switches set the operational mode of the DIF-800. The mode switches consist of an In/Out select switch and three Device Select switches.

The settings of the mode DIP switches become effective only when the power is turned on.

The selection of Master mode / Slave mode and settings for the device to be controlled can be also be made by a command from the DM-800. For details refer to "DM-800 parameter settings" (p.12).

### 5. In/Out Select Switch

This switch sets the operational mode of the DM-800 that is connected to the DIF-800.

#### IN (Slave Mode)

The DM-800 is placed under the control of the ADAT, DA-88, or video device.

#### OUT (Master Mode)

The DM-800 will control the ADAT, DA-88, or video device.



---

## 6. Device Select Switches

These switches select the device with which control and synchronization commands will be transmitted and received, and with which digital audio signals will be input and output.

### DA-88 (DA-88 Mode)



Commands will be transmitted/received and audio signals will be input/output to and from a DA-88.

### ADAT (ADAT Mode)



Commands will be transmitted/received and audio signals will be input/output to and from an ADAT.

### RS-422 (RS-422 Mode)



Commands will be transmitted/received to and from an RS-422 compatible device.

In RS-422 mode, audio signals will not be input/output between the external device and the DM-800 via the DIF-800.

## 7. Device ID Knob

Used to set the device ID of the DIF-800. Set this only when DA-88 mode is used.

### Note:

Device ID knob settings become effective only when the power is turned on. The device ID can also be set by a command from the DM-800. For details refer to "DM-800 parameter settings" (p.12).

## 8. DA-88 Sync In/Out Connector

This transmits and receives control commands between the DIF-800 and the DA-88.

Use a special DA-88 sync cable.

If the in/out select switch is at the "IN" (slave mode) position, this connector will function as the DA-88 Sync In connector. If the switch is at the "OUT" (master mode) position, this connector will function as the DA-88 Sync Out connector.

## 9. DA-88 TDIF-1 Connector

This connector inputs and outputs 8 channels of digital audio between the DIF-800 and the DA-88.

Use a special DA-88 dubbing cable.

## 10. ADAT Sync In/Out Connector

This connector transmits and receives control commands and synchronization signals between the DIF-800 and the ADAT.

Use a special ADAT sync cable.

If the in/out select switch is at the "IN" (slave mode) position, this connector will function as the ADAT Sync In connector. If the switch is at the "OUT" (master mode) position, this connector will function as the ADAT Sync Out connector.

## 11. ADAT Optical In Connector ADAT Optical Out Connector

These connectors input and output 8 channels of digital audio between the DIF-800 and the ADAT.

Use a special ADAT optical cable.

## 12. RS-422 In/Out Connector

This connector transmits and receives control commands between the DIF-800 and an RS-422 compatible video device.

Use a serial 9-pin cable.

If the in/out select switch is at the "IN" (slave mode) position, this connector will function as the RS-422 In connector. If the switch is at the "OUT" (master mode) position, this connector will function as the RS-422 Out connector.

## 13. Video Sync In Connector

When using an RS-422 compatible video device, this inputs a reference video signal for synchronization purposes.

Use a video cable.

# Connections

- \* To prevent malfunction and/or damage to speakers or other devices, always turn down the volume, and turn off the power on all devices before making any connections.
- \* The DIF-800 works only with a DM-800 running version 2.00 or later of the system software. If your DM-800 has a version of system software earlier than 2.00, you must have the software upgraded.
- \* For software upgrades, contact a nearby Roland service center.

## Connecting a DM-800 and an ADAT

- \* Audio tracks 1–8 of the ADAT correspond to digital input/output 1–8 of the DM-800's RMDB connector.

### Controlling the DM-800 from the ADAT

As shown in the diagram, connect the devices and set the DIF-800 mode DIP switches.

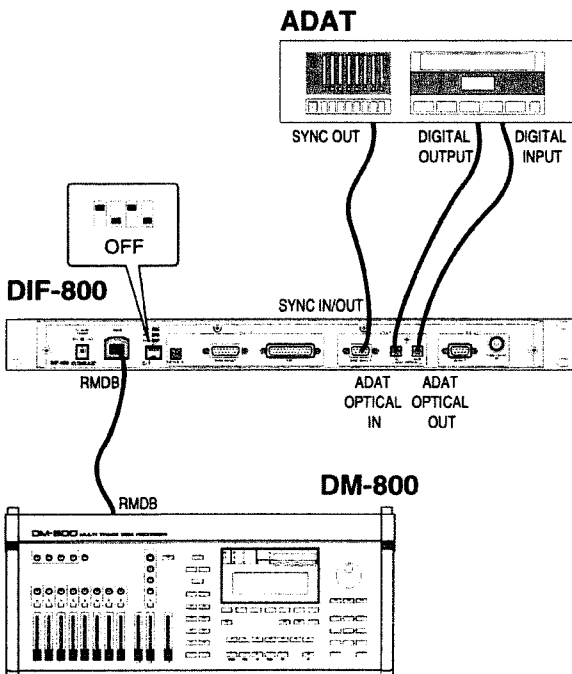

### Controlling the ADAT from the DM-800

As shown in the diagram, connect the devices and set the DIF-800 mode DIP switches.

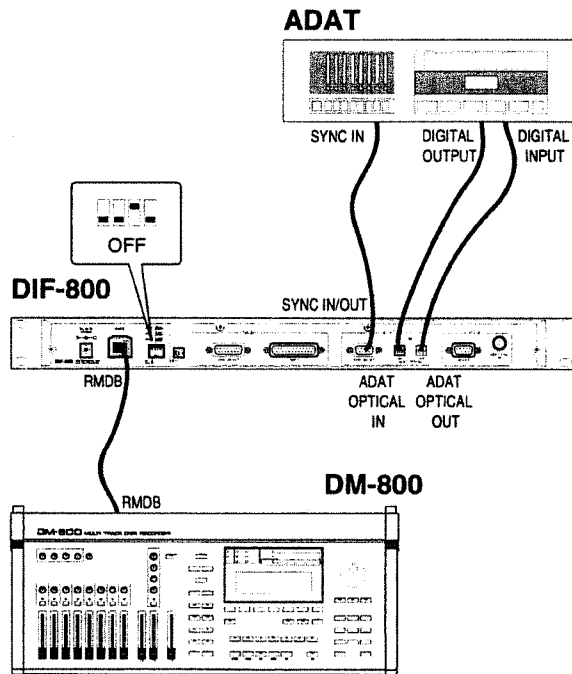

## Connecting a DM-800 and a DA-88

**Note:**

- When controlling the DM-800 from the DA-88, a Tascam RC-848 remote control unit is required. (If there is no RC-848, the DM-800 cannot be controlled.)
- DM-800 synchs to the ABS time(Absolute Time) on the DA-88.

\* Audio tracks 1–8 of the DA-88 correspond to digital input/output 1–8 of the DM-800's RMDB connector.

### Controlling the DM-800 from the DA-88 (RC-848)

1. As shown in the diagram, connect the devices and set the DIF-800 mode DIP switches.

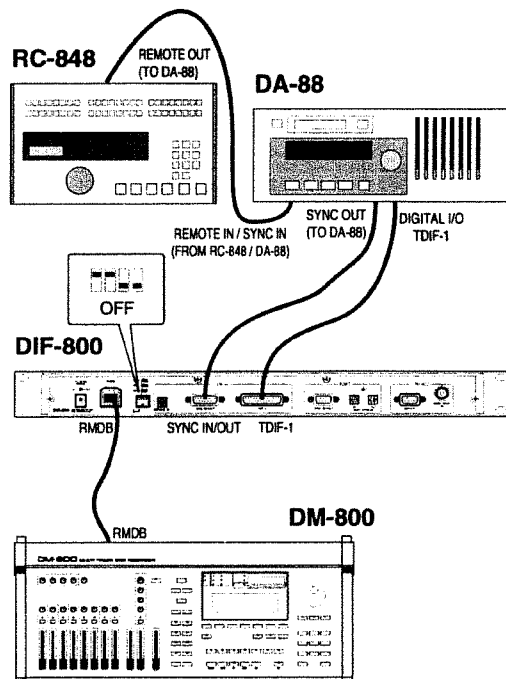

2. Set the DIF-800's device ID knob to a position other than 0 (zero).
3. Set the DA-88's MACHINE ID to 0 (zero).

**NOTE:**

Make sure that the DIF-800's device ID and the DA-88's machine ID are not the same. If the IDs are the same, the system may malfunction.

### Controlling the DA-88 from the DM-800

1. As shown in the diagram, connect the devices and set the DIF-800 mode DIP switches.

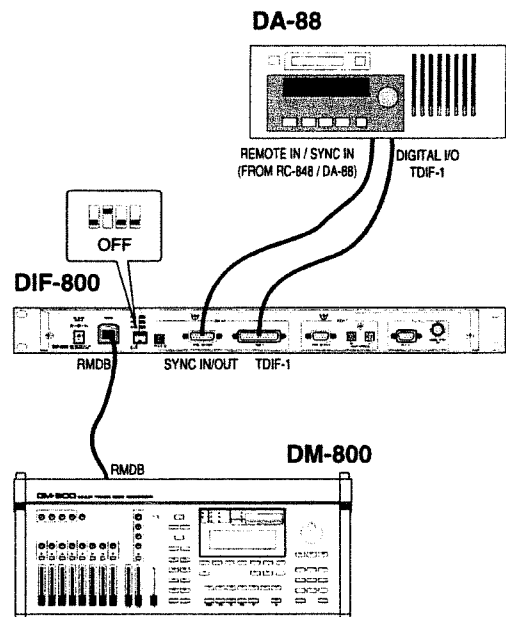

2. Set the DIF-800's device ID knob to 0 (zero).
3. On the DA-88 that is connected directly to the DIF-800, set the MACHINE ID to 0 (zero).

## Connecting a DM-800 and a VCR

**Note:**

- In order for the DM-800 and the video device to synchronize correctly, the same reference video signal must be provided to the video device and to the DIF-800.

### Controlling the DM-800 from the video

- ◆ As shown in the diagram, connect the devices and set the DIF-800 mode DIP switches.

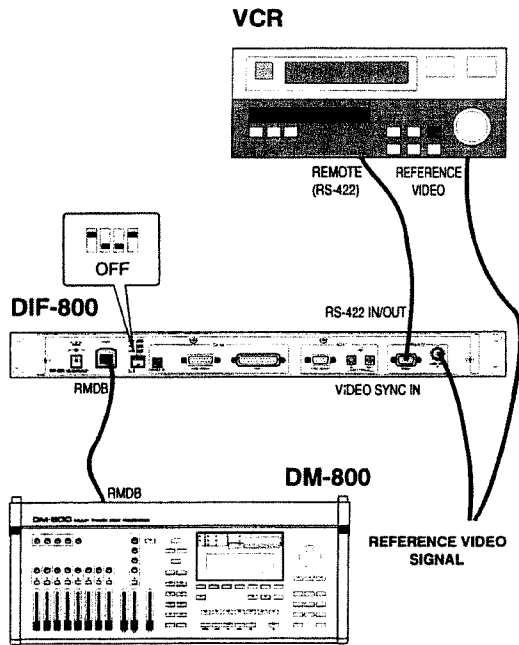

### Controlling the video device from the DM-800

- ◆ As shown in the diagram, connect the devices and set the DIF-800 mode DIP switches.

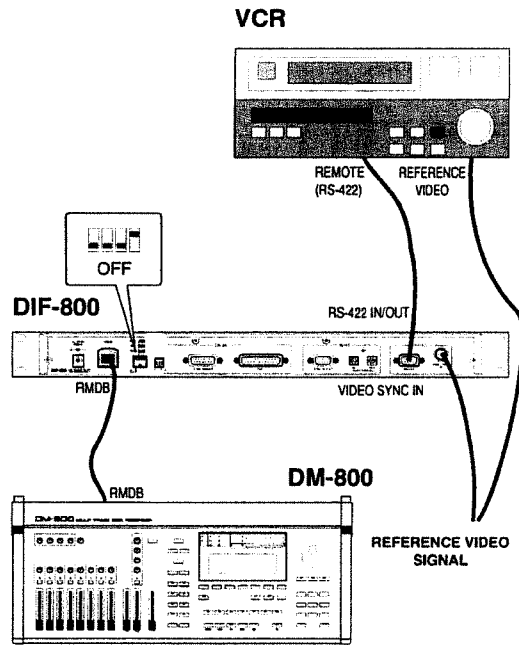

# Turning the power on/off

## To turn the power on .....

Before you turn on the power of each device, make sure that all devices are connected correctly.

### Note:

To prevent damage to your monitor speakers etc., lower the volume of your audio equipment before turning on any equipment.

1. If you are using a video device, turn on the power of the reference video signal source first.
2. Turn on the DIF-800 power. The status indicator will blink green.
  - \* When power is turned on, the DIF-800's protection circuit requires a few moments while it readies the unit for normal operation.
3. Turn on the DM-800 power and the power of any SCSI devices connected to the DM-800. The status indicator of the DIF-800 will change to steadily lit green.
4. Turn on the power of your ADAT or DA-88, video device, and audio equipment.
5. While the DM-800 checks the DIF-800 connections, it will display a message like the following.

```
Loading Startup Project...  
Found DIF-800 Ver.1.00
```

- \* Do not connect or disconnect cables while the unit is operating.

## To turn the power off.....

1. Turn off the power of the ADAT, DA-88, video device, and audio devices.
2. Perform shut-down operations for the DM-800 and the SCSI devices connected to the DM-800, and turn their power off.
3. Turn off the DIF-800 power.
4. If you are using a video device, turn off the source of the reference video signal.

# DM-800 Parameter Settings

Various parameter settings need to be made on the DM-800 so that control commands can be transmitted and received, and for synchronization to take place.

1. Press [SYSTEM]. The DM-800 will enter System mode.

2. Press [F4] (Page-) or [F5] (Page+) several times to access the Project Parameter 1 screen.



3. Set the Sampling Clock Source as appropriate for your situation.

When using the DIF-800, set this to RMDB.

**Internal:** The sampling clock will be generated from the DM-800 internal clock.

**Digital IN:** The sampling clock will be taken from the digital device connected to the digital input connector. Use this setting when digitally recording audio signals from the digital input connector.

**SMPTE:** The sampling clock will be generated from the SMPTE time code input from the SMPTE input connector. Use this setting when the time base is SMPTE.

**RMDB:** The sampling clock will be taken from the device connected to the RMDB connector. Use this setting when you wish to transfer audio signals via the RMDB connector.

4. Set the Time Base as appropriate for your situation. When using the DIF-800, set this to RMDB.

**Internal:** The times and durations for recording or playback will be determined by the DM-800 internal clock.

**SMPTE:** When the DM-800 is playing back, SMPTE time code received from the SMPTE input connector will be used to manage times and durations. Use this setting when you are using SMPTE time code to synchronize with video equipment, etc.

**MTC (MIDI Time Code):**

When the DM-800 is playing back, MIDI time code received from the MIDI IN connector will be used to manage times and durations. Use this setting when you are using MIDI time code to synchronize with MIDI devices.

**RMDB:** Times and durations will be managed by the device connected to the RMDB connector. Use this setting when you are synchronizing to the device connected to the RMDB connector.

If you are not editing time parameters, holding down the [SHIFT] before pressing the marker button [2] will set the time base to RMDB.

## Setting DIF-800 mode DIP switches and the Device ID from the DM-800

The settings of the mode DIP switches and the device ID knob located on the rear panel of the DIF-800 can be changed using DM-800 commands.

1. Press [SYSTEM]. The DM-800 will enter System mode.

2. Press [F4] (Page-) or [F5] (Page+) several times to access the DIF-800 setup screen.

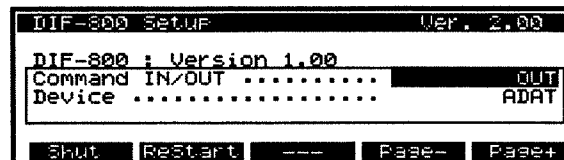

#### DIF-800 (DIF-800 system version screen)

This displays the version of the DIF-800 system software. If a DIF-800 is not connected to the DM-800, the display will indicate "Non Connect".

#### Command IN/OUT

Use the value/time dial to select the operation mode of the DM-800 when the DIF-800 is connected.

#### IN (slave mode):

The device selected by the device setting will control the DM-800.

#### OUT (master mode):

The DM-800 will control the device selected by the device setting.

#### Device

Use the value/time dial to select the device with which the DIF-800 will transmit and receive control commands and synchronization signals, and input/output digital audio signals.

**DA-88:** Commands will be transmitted and received and audio signals will be input and output between the DIF-800 and a DA-88.



#### Device ID

If the Command IN/OUT setting is "IN" (slave mode), use the value/time dial to set the device ID of the DIF-800 (value: 1-15).

**ADAT:** Commands will be transmitted and received and audio signals will be input and output between the DIF-800 and an ADAT.

**RS-422:** Commands will be transmitted and received between the DIF-800 and an RS-422 compatible video device.

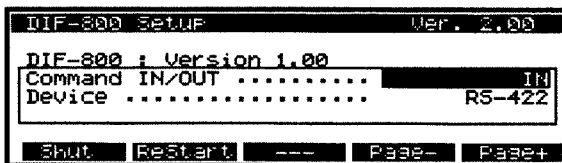

## About Local Edit mode

If you hold down [SHIFT] and press [SYSTEM], the DM-800 will enter "Local Edit mode," in which it will not transmit or receive commands or synchronization signals to/from external devices.

In Local Edit mode, the DM-800's [SYSTEM] button LED will blink red. In the System page, the upper part of the LCD will indicate "LOCAL."

In Local Edit mode, no commands or synchronization signals will be transmitted or received to/from external devices connected to the DM-800. Also, the system parameters and project parameters of the DM-800 will be temporarily set as follows.

**Time Base:** Internal  
**MTC Output:** Off  
**MIDI Clock Output:** OFF  
**MMC Device Mode:** OFF

SMPTE time code received from the SMPTE IN connector can be transmitted to the SMPTE OUT connector.

If you once again hold down [SHIFT] and press [SYSTEM], the DM-800 will exit Local Edit mode.

## Setups with a DM-800 and ADAT

### Transferring 8 channels of audio signal

When transferring audio signals between the DM-800 and the ADAT, be aware of the following points.

- Be sure to set the sampling rate of the DM-800 project to 48 kHz.
- Do not use pitch control (modification of the playback speed) on the ADAT. (Be sure to use the ADAT at the 'Standard Pitch'.)
- Tapes which were created using pitch control cannot be used.
- Do not make in/out assign settings on the DM-800 mixer that would cause the signal sent from the DM-800 to the RMDB digital output to be returned to the RMDB digital input. The signal loop may damage the audio devices which are connected to the DIF-800.

### <About the SMPTE Lock indicator>

When the sampling clock source is RMDB, the SMPTE lock indicator of the DM-800 will indicate the sampling clock status of the RMDB connector.

When the vertical line is near the center of the indicator, this indicates that the sampling clock from the external device is stable. If the vertical line sways greatly from left to right, the sampling clock from the external device is unstable.

When the sampling clock is unstable, audio signal can not be input/output via DIF-800 because of the noise generated by the unstable sampling clock. And it may damage the audio devices which are connected to the DIF-800.

If the sampling clock is unstable, check the following points.

- Are all devices connected correctly?
- Is the sampling rate of the DM-800 project set to 48 kHz?
- Is pitch control being used?

### Sending audio signals from the ADAT to the DM-800

#### •Connections and DIF-800 settings.....

1. Connect the ADAT, the DIF-800, and the DM-800. Set the device select switch of the DIF-800 to ADAT (ADAT mode).
2. Turn on the power of the DIF-800, DM-800, and ADAT. Insert a tape into the ADAT.

#### •DM-800 settings .....

3. In the Project parameter page, set the sampling clock source to RMDB.
4. In record mode, press [F3] (In/Out). The input/bus assign page will appear.
5. Press [F3](InRMDB). Digital inputs 1-8 of the RMDB connector will be assigned to tracks 1-8 of the DM-800. Press [EXIT]. You will return to the record page.

#### Note:

DM-800 tracks 1-8 correspond to ADAT tracks 1-8.

6. Press the track status select button for the desired tracks. The status LED of the track will change to red blinking, and the audio signals from the ADAT can be monitored on the DM-800.

### Sending audio signals from the DM-800 to the ADAT

#### •Connections and DIF-800 settings.....

1. Connect the ADAT, the DIF-800, and the DM-800. Set the device select switch of the DIF-800 to ADAT (ADAT mode).
2. Turn on the power of the DIF-800, DM-800, and ADAT. Insert a tape into the ADAT.

#### •DM-800 settings .....

3. In the project parameter page, set the sampling clock source to RMDB.



4. In record mode, press [F3] (In/Out). The input/bus assign page will appear.

Press [F1] (Output). The output assign page will appear.

5. Press [F5](BusTr). Tracks 1-8 of the DM-800 will be assigned to digital outputs 1-8 of the RMDB connector. Press [EXIT] twice to return to the record page.

Note:

- DM-800 tracks 1-8 correspond to ADAT tracks 1-8.
- To adjust volume or EQ for the tracks of the DM-800, press [F3](BusPst) in the input/bus assign page, and set the output bus of each track to Post Fader.

**•ADAT settings .....**

6. Press the [DIGITAL IN] switch of the ADAT. Press the TRACK ENABLE switch of the desired tracks. The RECORD and INPUT LEDs of the track will blink, allowing the audio signals from the DM-800 to be monitored on the ADAT.

**Exchanging commands**

**Operating the ADAT to control the DM-800**

**•Connections and DIF-800 settings.....**

1. Connect the ADAT, the DIF-800, and the DM-800. Set the mode DIP switches of the DIF-800 as follows.

- In/Out Select switch : IN (slave mode)
- Device Select switch : ADAT (ADAT mode)

2. Turn on the power of the DIF-800, DM-800, and ADAT. Insert a tape into the ADAT.

**•DM-800 settings .....**

3. In the project parameter page, make the following settings for the sampling clock source and the time base.

- Sampling Clock Source : RMDB
- Time Base : RMDB

4. Press the [PLAY] switch of the ADAT, and both the ADAT and the DM-800 will begin playback. Press the [STOP] switch and both the ADAT and the DM-800 will stop playback.

**Operating the DM-800 to control the ADAT**

**•Connections and DIF-800 settings.....**

1. Connect the ADAT, the DIF-800, and the DM-800. Set the mode DIP switches of the DIF-800 as follows.

- In/Out Select switch : OUT (master mode)
- Device Select switch : ADAT (ADAT mode)

2. Turn on the power of the DIF-800, DM-800, and ADAT. Insert a tape into the ADAT.

**•DM-800 settings .....**

3. In the project parameter page, make the following settings for the sampling clock source and the time base.

- Sampling Clock Source : RMDB
- Time Base : RMDB

4. Press the [PLAY] button of the DM-800, and both the DM-800 and the ADAT will begin playback. Press the [STOP] switch and both the DM-800 and the ADAT will stop playback.

## Setups with a DM-800 and DA-88 (RC-848)

### Transferring 8 channels of audio signal

When transferring audio signals between the DM-800 and the DA-88, be aware of the following points.

- Be sure to set the sampling rate of the DM-800 project to 48 kHz. or 44.1 kHz.
- Do not use pitch control (modification of the playback speed) on the DA-88. (Do not set the DA-88 to the pitch control mode.)
- Tapes which were created using pitch control cannot be used.
- It is not possible to use a tape on which the sampling rate changes during the tape.
- Do not make in/out assign settings on the DM-800 mixer that would cause the signal sent from the DM-800 to the RMDB digital output to be returned to the RMDB digital input. The signal loop may damage the audio devices which are connected to the DIF-800.

### <About the SMPTE Lock indicator>

When the sampling clock source is RMDB, the SMPTE lock indicator of the DM-800 will indicate the sampling clock status of the RMDB connector.

When the vertical line is near the center of the indicator, this indicates that the sampling clock from the external device is stable. If the vertical line sways greatly from left to right, the sampling clock from the external device is unstable.

When the sampling clock is unstable, audio signal can not be input/output via DIF-800 because of the noise generated by the unstable sampling clock. And it may damage the audio devices which are connected to the DIF-800.

If the sampling clock is unstable, check the following points.

- Are all devices connected correctly?
- Is the sampling rate of the DM-800 project set to 48 kHz or 44.1 kHz?
- Is pitch control being used?

### Sending audio signals from the DA-88 to the DM-800

#### •Connections and DIF-800 settings.....

1. Connect the DA-88, the RC-848, the DIF-800, the DM-800. Set the device select switch of the DIF-800 to DA-88 (DA-88 mode).
2. Turn on the power of the DIF-800, DM-800, and DA-88 (RC-848). Insert a tape into the DA-88.

#### •DM-800 settings .....

3. In the Project parameter page, set the sampling clock source to RMDB.
4. In record mode, press [F3] (In/Out). The input/bus assign page will appear.
5. Press [F3](InRMDB). Digital inputs 1-8 of the RMDB connector will be assigned to tracks 1-8 of the DM-800. Press [EXIT]. You will return to the record page.

#### Note:

DM-800 tracks 1-8 correspond to DA-88 tracks 1-8.

6. Press the track status select button for the desired tracks. The status LED of the track will change to red blinking, and the audio signals from the DA-88 can be monitored on the DM-800.

### Sending audio signals from the DM-800 to the DA-88

#### •Connections and DIF-800 settings.....

1. Connect the DA-88, the DIF-800, the DM-800. Set the device select switch of the DIF-800 to DA-88 (DA-88 mode).
2. Turn on the power of the DIF-800, DM-800. Insert a tape into the DA-88.

---

• **DM-800 settings** .....

3. In the project parameter page, set the sampling clock source to RMDB.
4. In record mode, press [F3] (In/Out). The input/bus assign page will appear.  
Press [F1] (Output). The output assign page will appear.
5. Press [F5](BusTr). Tracks 1–8 of the DM-800 will be assigned to digital outputs 1–8 of the RMDB connector. Press [EXIT] twice to return to the record page.

**Note:**

- DM-800 tracks 1–8 correspond to DA-88 tracks 1–8.
- To adjust volume or EQ for the tracks of the DM-800, press [F3](BusPst) in the input/bus assign page, and set the output bus of each track to Post Fader.

• **DA-88 settings** .....

6. Press the [DIGITAL IN] switch of the DA-88. Press the RECORD FUNCTION key of the desired tracks. The track LEDs will blink, allowing the audio signals from the DM-800 to be monitored on the DA-88.

**Changing commands**

DM-800 synchs to the ABS time(absolute time) on the DA-88.

DM-800 and DA-88 have their own time and duration management way respectively, so that the display of the time of the DM-800 may be different from that of the DA-88.

**Operating the DA-88 (RC-848) to control the DM-800**

• **Connections and DIF-800 settings**.....

1. Connect the DA-88, the RC-848, the DIF-800, the DM-800. Set the mode DIP switches of the DIF-800 as follows.  
In/Out Select switch : IN (slave mode)  
Device Select switch : DA-88 (DA-88 mode)  
Device ID knob : other than 0 (1–15)

**Note:**

Make sure that the device ID of the DIF-800 does not conflict with the MACHINE ID of the DA-88. If the IDs conflict, the system will malfunction.

2. Turn on the power of the DIF-800, DM-800, and DA-88 (RC-848). Insert a tape into the DA-88.

• **DM-800 settings** .....

3. In the project parameter page, make the following settings for the sampling clock source and the time base.  
Sampling Clock Source : RMDB  
Time Base : RMDB
4. Press the [PLAY] button of the RC-848. Both the DA-88 and the DM-800 will begin playback. Press the [STOP] key and both the DA-88 and the DM-800 will stop playback.

**Operating the DM-800 to control the DA-88**

• **Connections and DIF-800 settings**.....

1. Connect the DA-88, the DIF-800, the DM-800, and the source of the reference video signal. Set the mode DIP switches and device ID knob of the DIF-800 as follows.  
In/Out Select switch : OUT (master mode)  
Device Select switch : DA-88 (DA-88 mode)  
Device ID knob : 0
2. Turn on the power of the reference video signal source, the DIF-800, the DM-800, and the DA-88. Insert a tape into the DA-88.

• **DM-800 settings** .....

3. In the project parameter page, make the following settings for the sampling clock source and the time base.  
Sampling Clock Source : RMDB  
Time Base : RMDB
4. Press the [PLAY] button of the DM-800, and both the DM-800 and the DA-88 will begin playback. Press the [STOP] button and both the DM-800 and the DA-88 will stop playback.

## Setups with a DM-800 and video device

### Operating the video device to control the DM-800

#### Operating the video device to control the DM-800

##### •Connections and DIF-800 settings.....

1. Connect the video device, the DIF-800, the DM-800, and the source of the reference video signal. Set the mode DIP switches of the DIF-800 as follows.

In/Out Select switch : IN (slave mode)  
Device Select switch : RS-422 (RS-422 mode)

2. Turn on the power of the reference video signal source, DIF-800, DM-800, and video device.

##### •DM-800 settings .....

3. In the project parameter page, make the following settings for the sampling clock source and the time base.

Sampling Clock Source : RMDB  
Time Base : RMDB

4. Set the remote control select switch of the video device to "LOCAL."
5. On the video device, select the DM-800 as the device to be controlled.
6. Press the [PLAY] button of the video device, and the DM-800 will begin playback. Press the [STOP] button and the DM-800 will stop playback.

### Operating the DM-800 to control the video device

##### •Connections and DIF-800 settings.....

1. Connect the video device, the DIF-800, the DM-800, and the source of the reference video signal. Set the mode DIP switches of the DIF-800 as follows.

In/Out Select switch : OUT (master mode)  
Device Select switch : RS-422 (RS-422 mode)

2. Turn on the power of the reference video signal source, the DIF-800, the DM-800, and the video device. Insert a tape into the video device.

##### •DM-800 settings .....

3. In the project parameter page, make the following settings for the sampling clock source and the time base.

Sampling Clock Source : RMDB  
Time Base : RMDB

4. Set the remote control select switch of the video device to "REMOTE."
5. Press the [PLAY] button of the DM-800, and both the DM-800 and the video device will begin playback. Press the [STOP] button and both the DM-800 and the video device will stop playback.

##### Note:

If you are using a video tape recorder as the video device, putting the DM-800 into record mode will not put the video tape recorder into record mode.

## Software Updates

The system software of the DIF-800 may be updated from time to time, offering improved and/or added functionality. For information on software updates, contact your nearby Roland Service Station.

# Audio signal section block diagram

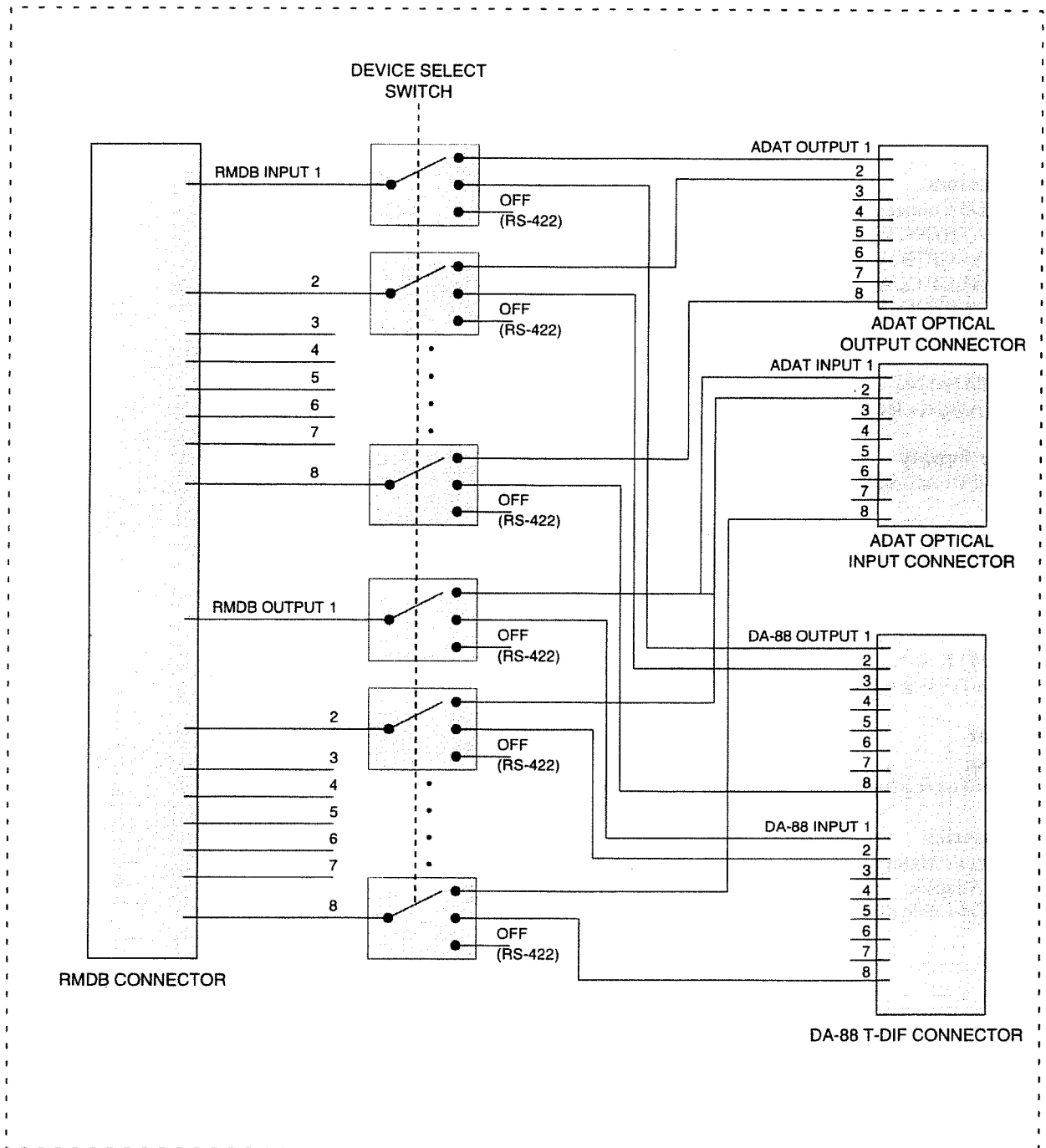

# Specifications

## DIF-800 : Digital Interface for ADAT/DA-88/RS-422

### Interface

DM-800 : RMDB (Roland Multipurpose Digital Buss)  
ADAT : SYNC IN/OUT, ADAT OPTICAL IN,  
ADAT OPTICAL OUT  
DA-88 : SYNC IN/OUT, TDIF-1  
RS-422 : RS-422 IN/OUT, VIDEO SYNC IN

### Connectors

RMDB Connector (30-pin HDI type)  
ADAT SYNC IN/OUT Connector (DB-9 type)  
ADAT OPTICAL IN Connector (Optical type)  
ADAT OPTICAL OUT Connector (Optical type)  
DA-88 SYNC IN/OUT Connector (DB-15 type)  
DA-88 TDIF-1 Connector (DB-25 type)  
RS-422 IN/OUT Connector (DB-9 type)  
VIDEO SYNC IN Connector (BNC type)  
AC Adaptor Jack (DC 9 V)

### Power Supply

DC 9 V : AC Adaptor

### Current Draw

400 mA

### Dimensions

482 (W) X 291 (D) X 46 (H) mm  
19 (W) X 11-1/2 (D) X 1-13/16 (H) inches  
(EIA-1U rack mount type)

### Weight

2.8 kg  
6 lbs 3 oz (excluding AC Adaptor)

### Accessories

Owner's Manual  
AC Adaptor  
RMDB Cable (3 m)

\* In the interest of product development, the specifications and/or appearance of this unit are subject to change without prior notice.

## Information

When you need repair service, call your local Roland Service Station or the authorized Roland distributor in your country as shown below.

### ARGENTINA

**Instrumentos Musicales S.A.**  
Florida 638  
(1005) Buenos Aires  
ARGENTINA  
TEL: (01) 394 4029

### BRAZIL

**Roland Brasil Ltda.**  
R. Coronel Octaviano da Silveira  
203 05522-010  
Sao Paulo BRAZIL  
TEL: (011) 843 9377

### CANADA

**Roland Canada Music Ltd. (Head Office)**  
5480 Parkwood Way Richmond  
B.C., V6V 2M4 CANADA  
TEL: (604) 270 6626

**Roland Canada Music Ltd. (Toronto Office)**  
Unit 2, 109 Woodbine Downs  
Blvd, Etobicoke, ON  
M9W 6Y1 CANADA  
TEL: (416) 213 9707

### MEXICO

**Casa Veerkamp, s.a. de c.v.**  
Mesones No. 21 Col. Centro  
Mexico D.F. 06080 MEXICO  
TEL: (905) 709 3716

### La Casa Wagner de

**Guadalajara s.a. de c.v.**  
Av. Corona No. 202 S.J.  
Guadalajara, Jalisco Mexico  
C.P. 44100 MEXICO  
TEL: (03) 613 1414

### PANAMA

**Productos Superiores, S.A.**  
Apartado 655 - Panama 1  
REP. DE PANAMA  
TEL: 26 3322

### U. S. A.

**Roland Corporation U.S.**  
7200 Dominion Circle  
Los Angeles, CA. 90040-3696,  
U. S. A.  
TEL: (0213) 685 5141

### VENEZUELA

**Musicaland Digital C.A.**  
Av. Francisco de Miranda,  
Centro Parque de Cristal, Nivel  
C2 Local 20 Caracas  
VENEZUELA  
TEL: (02) 285 9218

### AUSTRALIA

**Roland Corporation  
Australia Pty. Ltd.**  
38 Campbell Avenue  
Dee Why West. NSW 2099  
AUSTRALIA  
TEL: (02) 982 8266

### NEW ZEALAND

**Roland Corporation (NZ)  
Ltd.**  
97 Mt. Eden Road, Mt. Eden,  
Auckland 3, NEW ZEALAND  
TEL: (09) 3098 715

### HONG KONG

**Tom Lee Music Co., Ltd.  
Service Division**  
22-32 Fun Shan Street, Tsuen  
Wan, New Territories, HONG  
KONG  
TEL: 2415 0911

### INDONESIA

**PT CITRARAMA  
BELANTIKA**  
Kompleks Perkantoran Duta  
Merlin Blok E No.6 -7  
Jl. Gajah Mada No.3-5, Jakarta  
10130,  
INDONESIA  
TEL: (021) 3850073

### KOREA

**Cosmos Corporation  
Service Station**  
261 2nd Floor Nak-Won Arcade  
Jong-Ro ku, Seoul, KOREA  
TEL: (02) 742 8844

### MALAYSIA

**Bentley Music SDN BHD**  
No.142, Jalan Bukit Bintang 55100  
Kuala Lumpur, MALAYSIA  
TEL: (03) 2443333

### PHILIPPINES

**G.A. Yupangco & Co. Inc.**  
339 Gil J. Puyat Avenue  
Makati, Metro Manila 1200,  
PHILIPPINES  
TEL: (02) 899 9801

### SINGAPORE

**Swee Lee Company  
BLOCK 231,**  
Bain Street #03-23  
Bras Basah Complex,  
SINGAPORE 0718  
TEL: 3367886

### CRISTOFORI MUSIC PTE

**LTD**  
335, Joo Chiat Road SINGAPORE  
1542  
TEL: 3450435

### TAIWAN

**Siruba Enterprise (Taiwan)  
Co., LTD.**  
Room 5, 9th. No. 112 Chung Shan  
N. Road Sec.2 Taipei, TAIWAN,  
R.O.C.  
TEL: (02) 561 3339

### THAILAND

**Theera Music Co., Lt d.**  
330 Verng Nakorn Kasem, Soi 2,  
Bangkok 10100, THAILAND  
TEL: (02) 2248821

### BAHRAIN

**Moon Stores**  
Bad Al Bahrain Road,  
P.O. Box 20077  
State of BAHRAIN  
TEL: 211 005

### IRAN

**TARADIS**  
Mir Emad Ave. No. 15, 10th street  
P. O. Box 15875/4171 Teheran,  
IRAN  
TEL: (021) 875 6524

### ISRAEL

**Halilit P. Greenspoon &  
Sons Ltd.**  
8 Retzif Ha'aliya Hashnya St.  
Tel-Aviv-Yafa ISRAEL  
TEL: (03) 6823666

### JORDAN

**AMMAN Trading Agency**  
Prince Mohammed St. P. O. Box  
825 Amman 11118 JORDAN  
TEL: (06) 641200

### KUWAIT

**Easa Husain Al-Yousifi**  
P.O. Box 126 Safat 13002  
KUWAIT  
TEL: 5719499

### LEBANON

**A. Chahine & Fils**  
P.O. Box 16-5857 Gergi Zeidan St.  
Chahine Building, Achrafieh  
Beirut, LEBANON  
TEL: (01) 335799

### OMAN

**OHI Electronics &  
Trading Co. LLC**  
P. O. Box 889 Muscat  
Sultanate of OMAN  
TEL: 706 010

### QATAR

**Badie Studio & Stores**  
P.O.Box 62,  
DOHA QATAR  
TEL: 423554

### SAUDI ARABIA

**SAF Music Center**  
AL-Khobar 31952, P. O. Box 1366  
SAUDIARABIA  
TEL: (03) 898 3311

**Abdul Latif S. Al-Ghamdi  
Trading Establishment**  
Al-Tamini Commercial And  
Residential Center Al-Khobar  
Dharran Highway W/Hamood St.  
P. O. Box 3631 Al-Khobar  
31952 SAUDI ARABIA  
TEL: (03) 898 2332

### SYRIA

**Technical Light & Sound  
Center**  
Khaled Ebn Al Walid St.  
P.O. Box 13520  
Damascus - SYRIA  
TEL: (011) 2235 384

### TURKEY

**Barkat Sanayi ve Ticaret**  
Siraselvier Cad. Guney Ishani No.  
86/6 Taksim, Istanbul TURKEY  
TEL: (0212) 2499324

### U.A.E

**Zak Electronics & Musical  
Instruments Co.**  
Zabeel Road, Al Sherooq Bldg.,  
No. 14, Grand Floor DUBAI  
U.A.E.  
P.O. Box 8050 DUBAI, U.A.E  
TEL: (04) 360715

### EGYPT

**Al Fanny Trading Office**  
9, Ebn Hagar Ai Askalany Street,  
Ard El Golf, Heliopolis, Cairo,  
11341 EGYPT  
TEL: (02) 4171828  
(02) 4185531

### MAURITIUS

**Philanone Music Center**  
4th, Floor Noll, Happy World  
House Sir William Newton Street  
Port Luis MAURITIUS  
TEL: 242 2986

### REUNION

**FO - YAM Marcel**  
25 Rue Jules Mermet ZL  
Chaudron - BF79 97491  
Ste Clotilde REUNION  
TEL: 28 29 16

### SOUTH AFRICA

**That Other Music Shop  
(PTY) Ltd.**  
11 Melle Street (Cnr Melle and  
Juta Street)  
Braamfontein 2001  
Republic of SOUTH AFRICA  
TEL: (011) 403 4105

**Paul Bothner (PTY) Ltd.**  
17 Werdmuller Centre Claremont  
7700  
Republic of SOUTH AFRICA  
TEL: (021) 64 4030

### AUSTRIA

**E. Dematte & Co.**  
Neu-Rum Siemens-Strasse 4  
A-6040 Innsbruck P.O. Box 83  
AUSTRIA  
TEL: (0512) 26 44 260

### BELGIUM/HOLLAND/ LUXEMBOURG

**Roland Benelux N. V.**  
Houtstraat 1 B-2260 Oevel-  
Westerlo BELGIUM  
TEL: (014) 575811

### CYPRUS

**Radex Sound Equipment  
Ltd.**  
17 Diagorou St., P.O.Box 2046,  
Nicosia CYPRUS  
TEL: (02) 453 426  
(02) 466 423

### DENMARK

**Roland Scandinavia A/S**  
Langebrogade 6 Post Box 1937  
DK-1023 Copenhagen K.  
DENMARK  
TEL: 32 95 3111

### FRANCE

**Guillard Musiques Roland**  
ZAC de Rosarge Les Echets 01700  
MIRIBEL FRANCE  
TEL: 7226 5060

**Guillard Musiques Roland  
(Paris Office)**  
1923 rue Léon Geofroy 94400  
VITRY-SUR-SEINE FRANCE  
TEL: (1) 4680 86 62

### FINLAND

**Roland Scandinavia As,  
Filial Finland**  
Lautasaarentie 54 B  
Fin-00201 Helsinki, FINLAND  
P. O. Box No. 109  
TEL: (0) 682 4020

### GERMANY

**Roland Elektronische  
Musikinstrumente  
Handelsgesellschaft mbH.**  
Osistrasse 96, 22844 Norderstedt,  
GERMANY  
TEL: (0) 52 60090

### GREECE

**V. Dimitriadis & Co. Ltd.**  
20, Alexandras St. & Bouboulinas  
54 St. 106 82 Athens, GREECE  
TEL: (01) 8232415

### HUNGARY

**Intermusica Ltd.**  
Warehouse Area 'DEPO' P.83  
H-2046 Torokbalint, HUNGARY  
TEL: (01) 1868905

### IRELAND

**The Dublin Service Centre  
Audio Maintenance  
Limited**  
11 Brunswick Place Dublin 2  
Republic of IRELAND  
TEL: (01) 677322

### ITALY

**Roland Italy S. p. A.**  
Viale delle Industrie, 8  
20020 Arese Milano, ITALY  
TEL: (02) 93581311

### NORWAY

**Roland Scandinavia Avd.  
Kontor Norge**  
Lilleakerveien 2 Postboks 95  
Lilleaker N-0216 Oslo  
NORWAY  
TEL: 273 0074

### POLAND

**P. P. H. Brzostowicz Marian**  
61-502 Poznan, ul. Filarecka 11,  
TEL: (061) 332 665  
03-624 Warszawa, ul. Blokowa32,  
TEL: (02) 679 44 19

### PORTUGAL

**Caius - Tecnologias Audio e  
Musica, Lda.**  
Rue de Caiarina 131  
4000 Porto, PORTUGAL  
TEL: (02) 38 4456

### RUSSIA

**PETROSHOP**  
Vershavskoe, Shosse, 27-1  
Moscow, RUSSIA  
TEL: 095 901 0892

**INVASK Limited**  
Lenina Str. 13-342  
Krasnogorsk 143400  
Moscow Region, RUSSIA  
TEL: 095 564 61 44

### SPAIN

**Roland Electronics  
de España, S. A.**  
Calle Bolivia 239 08020 Barcelona,  
SPAIN  
TEL: (93) 308 1000

### SWEDEN

**Roland Scandinavia A/S**  
Danvik Center 28 A, 2 tr.  
S-131 30 Nacka SWEDEN  
TEL: (08) 702 0020

### SWITZERLAND

**Roland (Switzerland) AG  
Musitronic AG**  
Gerberstrasse 5, CH-4410 Liestal,  
SWITZERLAND  
TEL: (061) 921 1615

### UNITED KINGDOM

**Roland (U.K.) Ltd., Swansea  
Office**  
Atlantic Close, Swansea  
Enterprise Park SWANSEA  
West Glamorgan SA7 9JF,  
UNITED KINGDOM  
TEL: (01792) 702701

# MEMO

---



# Error messages

If external devices are set or connected incorrectly, or if the DIF-800 was not able to execute a command correctly, the DIF-800 will temporarily show an error message in the LCD of the DM-800. (The previous display will reappear when you press any button on the DM-800.)

---

**Sampling Clock is unstable between the DM-800 and the DA-88.**

**Check the sampling rate, VARI SPEED.**

- The sampling rate of the current project of the DM-800 does not match the sampling rate of the tape in the DA-88.  
→ Set the sampling rate to match.
- The DA-88 is set to Pitch Control mode.  
→ Turn off Pitch Control mode on the DA-88.

---

**Sampling Clock is unstable between the DM-800 and the ADAT.**

**Check the sampling rate, PITCH CTRL.**

- The sampling rate of the current project of the DM-800 does not match the sampling rate of the tape in the DA-88.  
→ Set the sampling rate to match.
- The playback pitch of the ADAT is not "standard pitch."  
→ Set the playback pitch of the ADAT to "standard pitch."

---

**Reference Video Signal does not come from VIDEO SYNC IN connector.**

**Check the cable connection.**

- A reference video signal is not being input.  
→ Connect the reference video signal cable to the Video Sync In connector.

---

**Cannot communicate to the DA-88 via DA-88 SYNC IN/OUT connector.**

**Check the cable connection.**

- Commands necessary for control cannot be exchanged with the DA-88 (RC-848).  
→ Connect the sync cable from the DA-88 (RC-848) to the Sync In/Out connector of the DA-88.

---

**Cannot communicate to the Video device via RS-422 IN/OUT connector.**

**Check the cable connection.**

- Commands necessary for control cannot be exchanged with the video device.  
→ Connect the 9-pin serial cable from the video device to the RS-422 In/Out connector.

---

**Cannot readout the Timecode from the Video Tape.**

- Time code could not be read from the video tape.  
→ Use a video tape on which time code has been correctly written.

---

**Cannot Record! Tape is write-protected.**

- Since the tape being used by the DA-88 or ADAT is write-protected, recording is not possible.  
→ Insert a tape on which recording is possible.

---

**Cannot control the device.**

**The device is in LOCAL MODE, or has No Tape. ( Tape Ejected? )**

- The remote control select switch of the video device is in the "LOCAL" position.  
→ Set the remote control select switch to "REMOTE."
- There is no tape in the ADAT, DA-88, or video device.  
→ Insert a tape.

## Precautions

Before use, please be sure to read this section together with the owner's manual.

When operating the DIF-800, please be aware of the following points.

### ■ Using the DM-800 with the ADAT

If you are operating the ADAT to control the DM-800 (i.e., when the In/Out Select switch of the DIF-800 is in the IN (slave mode) position), set the Digital 48K Master Clock setting of the ADAT to "int."

### ■ Using the DM-800 with the DA-88 (RC-848)

- If you are operating the RC-848 to control a DA-88 whose MACHINE ID is set to 0, the DM-800 will be controlled at the same time. If you wish to control only the DA-88 whose MACHINE ID is set to 0, put the DM-800 in "Local Edit mode."
- If a SY-88 synchronizer board is installed in the DA-88, be sure to set the Time Mode (the time handled by the DA-88) to ABS Time (absolute time).

# CORRECTIONS

Please make the following corrections in your Owner's Manual.

## **Page 4 Contents, 6th line**

- (error) Connecting a DM-800 and a VTR
- (correct) Connecting a DM-800 and video device

## **Page 10 Title of the page**

- (error) Connecting a DM-800 and a VCR
- (correct) Connecting a DM-800 and video device

## **Page 17 Operating the DM-800 to control the DA-88**

### **"Connection and DIF-800 settings", Step 1**

- (error) Connect the DA-88, the DIF-800, the DM-800, and the source of the reference video signal. Set the mode DIP switches and Device ID knob of the DIF-800 as follows.
- (correct) Connect the DA-88, the DIF-800, the DM-800. Set the mode DIP switches and Device ID knob of the DIF-800 as follows.

### **"Connections and DIF-800 settings", Step 2**

- (error) Turn on the power of the reference video signal source, the DIF-800, DM-800, and the DA-88. Insert a tape into the DA-88.
- (correct) Turn on the power of the DIF-800, DM-800, and the DA-88. Insert a tape into the DA-88.



For the U.K.

**IMPORTANT: THE WIRES IN THIS MAINS LEAD ARE COLOURED IN ACCORDANCE WITH THE FOLLOWING CODE.**

BLUE: NEUTRAL  
BROWN: LIVE

As the colours of the wires in the mains lead of this apparatus may not correspond with the coloured markings identifying the terminals in your plug, proceed as follows:

The wire which is coloured BLUE must be connected to the terminal which is marked with the letter N or coloured BLACK.  
The wire which is coloured BROWN must be connected to the terminal which is marked with the letter L or coloured RED.  
Under no circumstances must either of the above wires be connected to the earth terminal of a three pin plug.

For Europe



This product complies with the requirements of European Directive 89/336/EEC.

For the USA

## FEDERAL COMMUNICATIONS COMMISSION RADIO FREQUENCY INTERFERENCE STATEMENT

This equipment has been tested and found to comply with the limits for a Class B digital device, pursuant to Part 15 of the FCC Rules. These limits are designed to provide reasonable protection against harmful interference in a residential installation. This equipment generates, uses, and can radiate radio frequency energy and, if not installed and used in accordance with the instructions, may cause harmful interference to radio communications. However, there is no guarantee that interference will not occur in a particular installation. If this equipment does cause harmful interference to radio or television reception, which can be determined by turning the equipment off and on, the user is encouraged to try to correct the interference by one or more of the following measures:

- Reorient or relocate the receiving antenna.
- Increase the separation between the equipment and receiver.
- Connect the equipment into an outlet on a circuit different from that to which the receiver is connected.
- Consult the dealer or an experienced radio/TV technician for help.

Unauthorized changes or modification to this system can void the users authority to operate this equipment.  
This equipment requires shielded interface cables in order to meet FCC class B Limit.

For Canada

### CLASS B NOTICE

This digital apparatus does not exceed the Class B limits for radio noise emissions set out in the Radio Interference Regulations of the Canadian Department of Communications.

### CLASSE B AVIS

Cet appareil numérique ne dépasse pas les limites de la classe B au niveau des émissions de bruits radioélectriques fixés dans le Règlement des signaux parasites par le ministère canadien des Communications.

 Roland®

70782701

UPC 70782701



10901

ROLAND

Roland Corporation

00907212 '95-11-H2-11D