

Roland®

POWERED MIXER

CPM-300

OWNER'S MANUAL

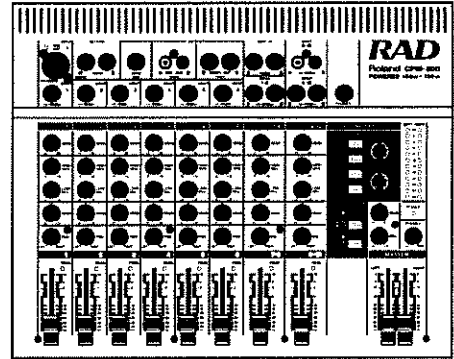

Before using this unit, carefully read the sections entitled: "IMPORTANT SAFETY INSTRUCTIONS" (p. 2), "USING THE UNIT SAFELY" (p. 3), and "IMPORTANT NOTES" (p. 4). These sections provide important information concerning the proper operation of the unit. Additionally, in order to feel assured that you have gained a good grasp of every feature provided by your new unit, this manual should be read in its entirety. The manual should be saved and kept on hand as a convenient reference.

Main Features

● Lightweight, Compact, and Energy-Efficient

Employing the latest developments in high-efficiency amplifier technology, the CPM-300 packs a powerful 150 watts per channel (into 4 ohms), yet weighs a mere 6.0 kilograms, consumes only half the energy, and generates just one-third the heat of previous powered mixers (in actual operation, compared with other Roland mixers). The compact design means you can easily find space to set it up, and it travels a lot easier. The handles make this piece of gear easy to carry, too. The CPM-300 is ideal as a simple PA for a variety of events, and since it is air-cooled, it stays quiet.

● Packed with Features, Yet Simple to Operate

The CPM-300 provides six mono and two stereo channels for a total of ten input channels. With its widely-adjustable input circuits, the SENS knobs allow you to adjust the input sensitivity with the twist of just one control. This allows the CPM-300 to accept a wide range of inputs, from mics to CD players to electronic instruments, all with a simple adjustment.

● Easy Elimination of Irritating Feedback

The CPM-300 features a digitally processed "Anti-Feedback" function. Feedback is automatically detected and eliminated the instant it begins.

● The high-quality internal effects include four types of digital reverb.

A few simple steps let you perform with these superior effect sounds, from karaoke-style echo to concert hall reverb sound, with ease.

● Limiter Included in Power Amp Section



The mixer's amplifier is equipped with a limiter circuit, providing protection against the clipping that can cause distortion and blown speakers.

● Protection Circuits for Added Reliability

With a PC Limiter Circuit which guards against shorting in the output, a Thermal Protection Circuit, a speaker-saving DC Detection Circuit, a Muting Circuit that cuts the "shock noise" that occurs when the power is switched on, and more, the CPM-300 features a variety of protection circuits to ensure dependable operation.

New ECOS High-Efficiency Amplifier Technology

ECOS (Efficiency Control Operation System) is a new high-efficiency amplifier technology developed by Roland. With this technology, amplifier power consumption is only 1/2 that of previous amps, while generating only 1/3 of the heat, all with no sacrifice in sound quality. As a result, the heat dissipation and power sections are smaller, making the mixer lighter and more compact than previous models.

	CAUTION RISK OF ELECTRIC SHOCK DO NOT OPEN	
ATTENTION RISQUE DE CHOC ELECTRIQUE NE PAS OUVRIR		
<p>CAUTION: TO REDUCE THE RISK OF ELECTRIC SHOCK, DO NOT REMOVE COVER (OR BACK). NO USER-SERVICEABLE PARTS INSIDE. REFER SERVICING TO QUALIFIED SERVICE PERSONNEL.</p>		



The lightning flash with arrowhead symbol, within an equilateral triangle, is intended to alert the user to the presence of uninsulated "dangerous voltage" within the product's enclosure that may be of sufficient magnitude to constitute a risk of electric shock to persons.



The exclamation point within an equilateral triangle is intended to alert the user to the presence of important operating and maintenance (servicing) instructions in the literature accompanying the product.

INSTRUCTIONS PERTAINING TO A RISK OF FIRE, ELECTRIC SHOCK, OR INJURY TO PERSONS.

IMPORTANT SAFETY INSTRUCTIONS SAVE THESE INSTRUCTIONS

WARNING - When using electric products, basic precautions should always be followed, including the following:

1. Read all the instructions before using the product.
2. Do not use this product near water — for example, near a bathtub, washbowl, kitchen sink, in a wet basement, or near a swimming pool, or the like.
3. This product should be used only with a cart or stand that is recommended by the manufacturer.
4. This product, either alone or in combination with an amplifier and headphones or speakers, may be capable of producing sound levels that could cause permanent hearing loss. Do not operate for a long period of time at a high volume level or at a level that is uncomfortable. If you experience any hearing loss or ringing in the ears, you should consult an audiologist.
5. The product should be located so that its location or position does not interfere with its proper ventilation.
6. The product should be located away from heat sources such as radiators, heat registers, or other products that produce heat.
7. The product should be connected to a power supply only of the type described in the operating instructions or as marked on the product.
8. The power-supply cord of the product should be unplugged from the outlet when left unused for a long period of time.
9. Care should be taken so that objects do not fall and liquids are not spilled into the enclosure through openings.
10. The product should be serviced by qualified service personnel when:
 - A. The power-supply cord or the plug has been damaged; or
 - B. Objects have fallen, or liquid has been spilled into the product; or
 - C. The product has been exposed to rain; or
 - D. The product does not appear to operate normally or exhibits a marked change in performance; or
 - E. The product has been dropped, or the enclosure damaged.
11. Do not attempt to service the product beyond that described in the user-maintenance instructions. All other servicing should be referred to qualified service personnel.

For the USA

GROUNDING INSTRUCTIONS

This product must be grounded. If it should malfunction or breakdown, grounding provides a path of least resistance for electric current to reduce the risk of electric shock.

This product is equipped with a cord having an equipment-grounding conductor and a grounding plug. The plug must be plugged into an appropriate outlet that is properly installed and grounded in accordance with all local codes and ordinances.

DANGER: Improper connection of the equipment-grounding conductor can result in a risk of electric shock. Check with a qualified electrician or serviceman if you are in doubt as to whether the product is properly grounded.

Do not modify the plug provided with the product — if it will not fit the outlet, have a proper outlet installed by a qualified electrician.

For the U.K.

WARNING: THIS APPARATUS MUST BE EARTHED
IMPORTANT: THE WIRES IN THIS MAINS LEAD ARE COLOURED IN ACCORDANCE WITH THE FOLLOWING CODE.
 GREEN-AND-YELLOW: EARTH, BLUE: NEUTRAL, BROWN: LIVE

As the colours of the wires in the mains lead of this apparatus may not correspond with the coloured markings identifying the terminals in your plug, proceed as follows:

The wire which is coloured GREEN-AND-YELLOW must be connected to the terminal in the plug which is marked by the letter E or by the safety earth symbol  or coloured GREEN or GREEN-AND-YELLOW.



The wire which is coloured BLUE must be connected to the terminal which is marked with the letter N or coloured BLACK.



The wire which is coloured BROWN must be connected to the terminal which is marked with the letter L or coloured RED.

The product which is equipped with a THREE WIRE GROUNDING TYPE LINE PLUG must be grounded.







USING THE UNIT SAFELY

INSTRUCTIONS FOR THE PREVENTION OF FIRE, ELECTRIC SHOCK, OR INJURY TO PERSONS

About  WARNING and  CAUTION Notices







 WARNING	Used for instructions intended to alert the user to the risk of death or severe injury should the unit be used improperly.
 CAUTION	Used for instructions intended to alert the user to the risk of injury or material damage should the unit be used improperly. * Material damage refers to damage or other adverse effects caused with respect to the home and all its furnishings, as well to domestic animals or pets.

About the Symbols

	The  symbol alerts the user to important instructions or warnings. The specific meaning of the symbol is determined by the design contained within the triangle. In the case of the symbol at left, it is used for general cautions, warnings, or alerts to danger.
	The  symbol alerts the user to items that must never be carried out (are forbidden). The specific thing that must not be done is indicated by the design contained within the circle. In the case of the symbol at left, it means that the unit must never be disassembled.
	The  symbol alerts the user to things that must be carried out. The specific thing that must be done is indicated by the design contained within the circle. In the case of the symbol at left, it means that the power-cord plug must be unplugged from the outlet.

ALWAYS OBSERVE THE FOLLOWING







WARNING

- Before using this unit, make sure to read the instructions below, and the Owner's Manual. 
- Do not open or perform any internal modifications on the unit. 
- Make sure you always have the unit placed so it is level and sure to remain stable. Never place it on stands that could wobble, or on inclined surfaces. 
- Avoid damaging the power cord. Do not bend it excessively, step on it, place heavy objects on it, etc. A damaged cord can easily become a shock or fire hazard. Never use a power cord after it has been damaged. 
- In households with small children, an adult should provide supervision until the child is capable of following all the rules essential for the safe operation of the unit. 
- Protect the unit from strong impact. (Do not drop it!) 
- Do not force the unit's power-supply cord to share an outlet with an unreasonable number of other devices. Be especially careful when using extension cords—the total power used by all devices you have connected to the extension cord's outlet must never exceed the power rating (watts/amperes) for the extension cord. Excessive loads can cause the insulation on the cord to heat up and eventually melt through. 

WARNING

- Before using the unit in a foreign country, consult with your retailer, the nearest Roland Service Center, or an authorized Roland distributor, as listed on the "Information" page. 

CAUTION

- Always grasp only the plug on the power-supply cord when plugging into, or unplugging from an outlet. 
- Try to prevent cords and cables from becoming entangled. Also, all cords and cables should be placed so they are out of the reach of children. 
- Never climb on top of, nor place heavy objects on the unit. 
- Never handle the power cord or its plug with wet hands when plugging into, or unplugging from, an outlet. 
- Before moving the unit, disconnect the power plug from the outlet, and pull out all cords from external devices. 
- Before cleaning the unit, turn off the power and unplug the power cord from the outlet (p. 9). 
- Whenever you suspect the possibility of lightning in your area, pull the plug on the power cord out of the outlet. 

Important Notes

In addition to the items listed under "IMPORTANT SAFETY INSTRUCTIONS" and "USING THE UNIT SAFELY" on pages 2 and 3, please read and observe the following:

Power Supply

- Do not use this unit on the same power circuit with any device that will generate line noise (such as an electric motor or variable lighting system).
- Before connecting this unit to other devices, turn off the power to all units. This will help prevent malfunctions and/or damage to speakers or other devices.

Placement

- Using the unit near power amplifiers (or other equipment containing large power transformers) may induce hum. To alleviate the problem, change the orientation of this unit; or move it farther away from the source of interference.
- This device may interfere with radio and television reception. Do not use this device in the vicinity of such receivers.

Maintenance

- For everyday cleaning wipe the unit with a soft, dry cloth or one that has been slightly dampened with water. To remove stubborn dirt, use a cloth impregnated with a mild, non-abrasive detergent. Afterwards, be sure to wipe the unit thoroughly with a soft, dry cloth.
- Never use benzine, thinners, alcohol or solvents of any kind, to avoid the possibility of discoloration and/or deformation.

Additional Precautions

- Use a reasonable amount of care when using the unit's buttons, sliders, or other controls; and when using its jacks and connectors. Rough handling can lead to malfunctions.
- When connecting / disconnecting all cables, grasp the connector itself—never pull on the cable. This way you will avoid causing shorts, or damage to the cable's internal elements.
- A small amount of heat will radiate from the unit during normal operation.
- To avoid disturbing your neighbors, try to keep the unit's volume at reasonable levels (especially when it is late at night).
- When you need to transport the unit, package it in the box (including padding) that it came in, if possible. Otherwise, you will need to use equivalent packaging materials.

Contents

Using The Unit Safely	3
Important Notes	4
Names and Functions	6
Front Panel.....	6
Channel Section.....	6
Master Section	7
Jacks and Connectors.....	8
Rear Panel.....	9
Side Panel	9
Connections	10
Basic Connections: An Example.....	10
Connecting an External Effects Processor or Equalizer	11
Checking Out the Sound	12
Precautions When Turning on the Power	12
Producing Sound with Microphones (Basic Knobs and Faders Adjustments)	12
Adjusting the Sound Quality with the Equalizer	12
Adding Reverberation to the Sound (Digital Reverb)	13
Operating the Digital Reverb.....	13
Eliminating Feedback (Anti-Feedback Function)	14
How to Avoid Feedback	14
Using the CPM-300's Anti-Feedback Function.....	14
Procedure for Operating the Auto Adjust Function.....	14
Notes Regarding the Auto Adjust Function.....	15
Dynamic Adjust Function	15
Common Notes about the Auto Adjust and Dynamic Adjust Functions	15
Further Details on the Anti Feedback Function	16
How the Removal of Feedback is Achieved	16
About the Safety Margin.....	16
About the Protection Circuits	17
Troubleshooting	18
Specifications	20
Input/Output Standards	21
Block Diagram	22
Dimensions	23
Blank User Settings Chart	24
Index	25

Names and Functions of Each Part

Front Panel

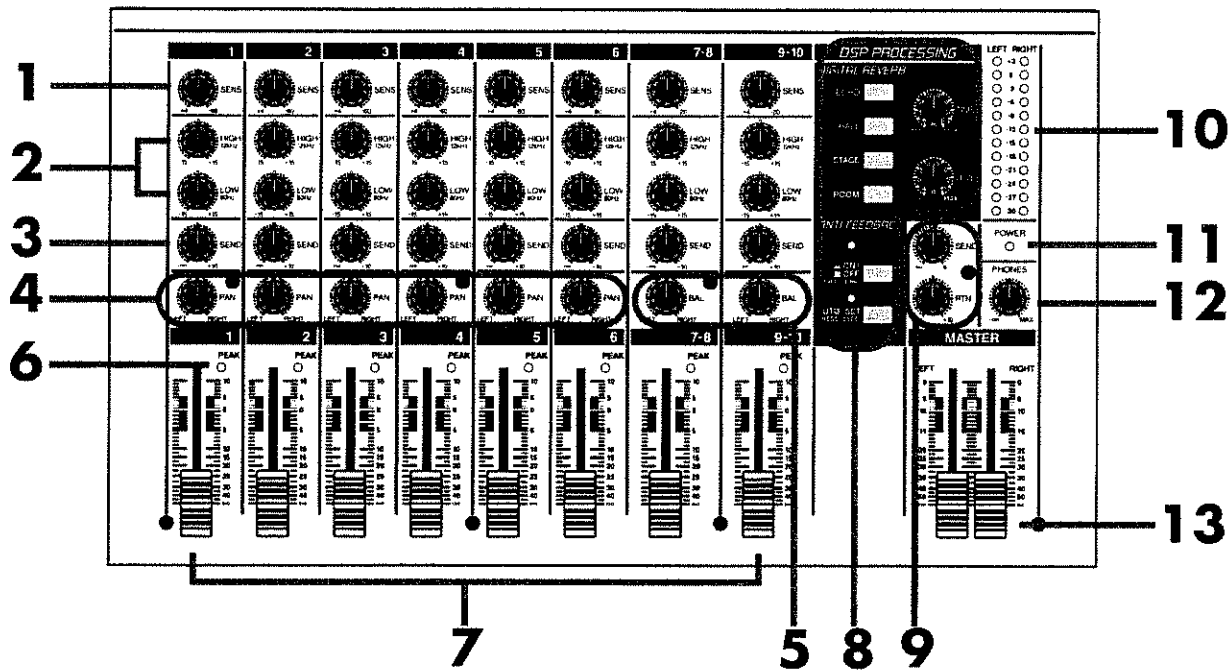

Channel Section

Input Channels

1-6 (MONO)

7-8, 9-10 (STEREO)

1.SENS Knob

This adjusts the sensitivity to ensure the proper input signal level. Adjust this knob so that the PEAK indicator (6) does not light too frequently.

* Rated Input Level Channel 1-6: +4 dBm to -60 dBm
 Channel 7-8, 9-10: +4 dBm to -20 dBm

2.EQ (Equalizer) Knob

Use these to adjust the tone quality of the input signal. Setting a knob to the 0 position provides a flat response. (→ p. 12)

3.SEND Knob

This adjusts the output level of the signal sent to the Master section SEND knob (9).

* Output is normal when the knob is set to the 0 position.

* This signal is output after passing through the channel fader (post-fader). (Refer to the Block Diagram → p. 22)

4.PAN (Panpot) Knob

This knob assigns the left-right distribution of each channel's output, localizing the sound within the stereo field. At center position, sound is localized at the center of the field (i.e., both the left and right channels are output at the same volume).

5.BAL (Balance) Knob

This adjusts the left-right balance of the output, adjusting the apparent location of the sound in the stereo field. At center position, sound is localized at the center (the volume is the same in both the left and right channels).

6. PEAK Indicator

These indicators light in red when the input signal level is too high. They go on at 6 dBm before clipping, warning that the signal is approaching clipping levels. The signal monitored by the PEAK indicator is post-EQ and post-fader (please refer to the Block Diagram → p. 22). Adjust the SENS knob (1) and Channel fader (7) so that the indicator does not light up too frequently.

7. Channel Faders

Each fader adjusts the output for its corresponding channel. The black areas along the fader markings make it easy to determine the range within which the faders can be set to avoid distortion and noise.

* Output is normal when the fader is set to the 0 position.

Master Section

8. DSP PROCESSING

● DIGITAL REVERB

The CPM-300 offers four types of internal digital reverb. (→ p. 13)

● ANTI FEEDBACK

Feedback is automatically detected and eliminated the instant it begins. (→ p. 14)

9. SEND/RETURN

● SEND Knob

This takes the signals adjusted by means of the individual channel SEND knobs (3), mixes them, adjusts the output, and sends it to the DSP PROCESSING (internal digital reverb) (8).

An identical signal is also sent to the SEND jack in the connector section.

* Output is normal when the knob is set to the 0 position.

● RTN (Return) Knob

This adjusts the input signal from the connector section's RETURN jack.

* Input is normal when the knob is set to the 0 position.

10. MASTER LEVEL Meter

This meter indicates the mixer section's output level (MIXER OUT level). When the 0 indicator is lit, it indicates that the output level is at +4 dBm.

The output of the mixer section is sent to the amplifier section, and this signal is output from the speaker terminals on the rear panel at 100 watts (when speakers with of 8 ohms are connected).

* When cables are connected to the AMP IN jacks, the mixer and amplifier sections are separated, and the signal from the mixer section is isolated. (→ p. 11)

11. POWER Indicator

This indicator lights up when the power up on.

12. PHONES Knob

This adjusts the headphones volume.

* The signal used for the headphones is taken before the MASTER faders (pre-fader) (please refer to the Block Diagram → p. 22).

* The headphones of this unit may be capable of producing sound levels that could cause permanent hearing loss. Do not operate for a long period of time at a high volume level, or at a level that is uncomfortable.

13. MASTER Faders (LEFT/RIGHT)

These adjust the final output level of the mix. The black areas along the fader markings make it easy to determine the range within which the faders can be set to avoid distortion and noise.

* Output is normal when the fader is set to the 0 position.

* The CPM-300's power amp features a built-in limiter circuit. This monitors the signal from the CPM-300's mixer to prevent clipping in the amp that can cause distorted sound and blown speakers.

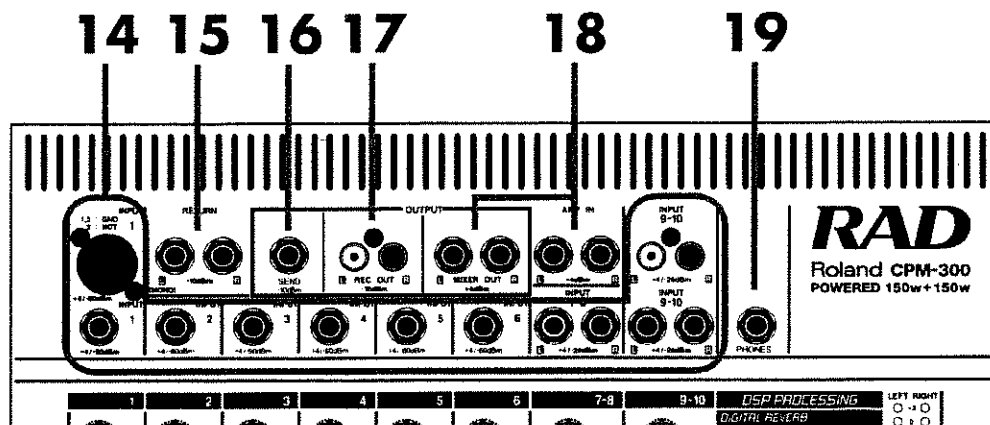

Jacks and Connectors

14.INPUT

These connector and jacks accept input of signals.

Channel 1 (MONO)

●XLR Type (Unbalanced Input)

- * Pins are wired as shown in the diagram below. Before connecting other devices, confirm that the pin assignment matches that of the CPM-300's input.
- * Pin 3 is connected to ground; take care when connecting to devices featuring balanced outs.

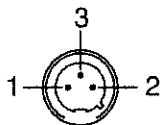

1:GND
2:HOT
3:GND

●TRS Standard Phone Type (Unbalanced Input)

- * Pins are wired as shown in the diagram below. Before connecting other devices, confirm that the pin assignment matches that of the CPM-300's input.
- * The ring is connected to ground; take care when connecting to devices featuring balanced outs.

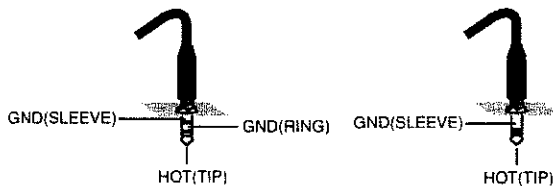

- * Use only one of the two inputs at any one time. Connecting to both inputs may result in insufficient volume.

Channels 2-6 (MONO), Channels 7-8 (STEREO)

●Standard Phone Type

Channels 9-10 (STEREO)

●Standard Phone Type

●RCA Phono Type

- * You can use either one. When both are used at the same time, connection to the standard type is given priority, and the other remains unconnected.

15.RETURN Jack (Standard Phone Type)

This is used for connecting external effects devices. The signal returned from the effect device is input here (→ p. 11). This also can be used as an auxiliary input. Mono input is possible by connecting only to the L input.

16.SEND Jack (Standard Phone Type)

This is used for connecting external effects devices. The signal sent to the effect device is output here (→ p. 11).

17.REC OUT Jack (RCA Phono Type)

These are the output jacks for recording. Use these to connect to external recording devices and similar equipment.

- * This signal is taken before the MASTER fader (pre-fader) (please refer to the Block Diagram → p. 22). While the MIXER OUT signal is output from this connector, it is unaffected by the MASTER faders (rated output level : -10 dBm).
- * Returning the output of the recording device during recording may result in unwanted oscillations in the sound.
- * During recording, completely lower the fader (set the fader to infinity) for the input channel connected to the output of the recording device.

18.MIXER OUT/AMP IN Jack (Standard Phone Type)

Connect an equalizer or compressor/limiter here. (→ p. 11)

- * When cables are connected to the AMP IN jacks, the mixer and amplifier sections are separated, and the signal from the mixer section is isolated. (→ p. 11)

- * Do not connect MIXER OUT Jacks directly to the speakers.

19.PHONES Jack (Stereo Standard Phone Type)

Headphones are plugged in here.

Rear Panel

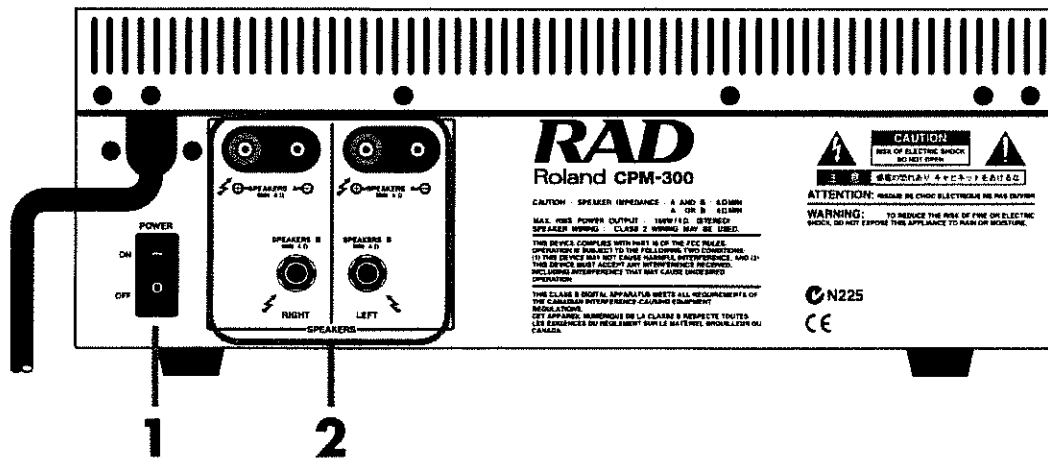

1. POWER Switch

* Turn the power on and off only after completely turning down all volume levels by lowering the faders and volume controls on the CPM-300 and any connected equipment.

2. Speaker Connection Terminals (Binding Post, Standard Phone Type)

These are the jacks and terminals for connecting the speakers. Two systems may be connected simultaneously. Minimum recommended load impedance for the CPM-300's power amp is 4 ohms.



<Combining Speakers>

Be sure to check the combined impedance when connecting multiple speaker pairs.

When connecting multiple speakers in parallel:

(Ex.)	8 ohms/8 ohms	→	4 ohms	YES
	6 ohms/8 ohms	→	3.4 ohms	NO
	6 ohms/6 ohms	→	3 ohms	NO
	4 ohms/4 ohms	→	2 ohms	NO

*Although the CPM-300 is protected from damage by the PC Control Circuit, take care not to connect speakers of less than 4 ohms impedance or to allow shorting in the speaker cables



<About the PC Limiter Circuit>

The PC Limiter Circuit works to protect the CPM-300 if the + and - wires of the speaker cable are shorted or if speakers with impedance of less than 4 ohms are used; this may result in no sound from the speakers or distortion.

Side Panel (Left side)

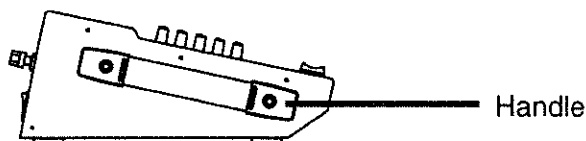

Handle

This is the mixer's carrying handle.

* Do not swing the unit around by the handle or pull on the handle with excessive force.

NOTE To prevent malfunction and/or damage to speakers or other devices, always turn down the volume, and turn off the power on all devices before making any connections.

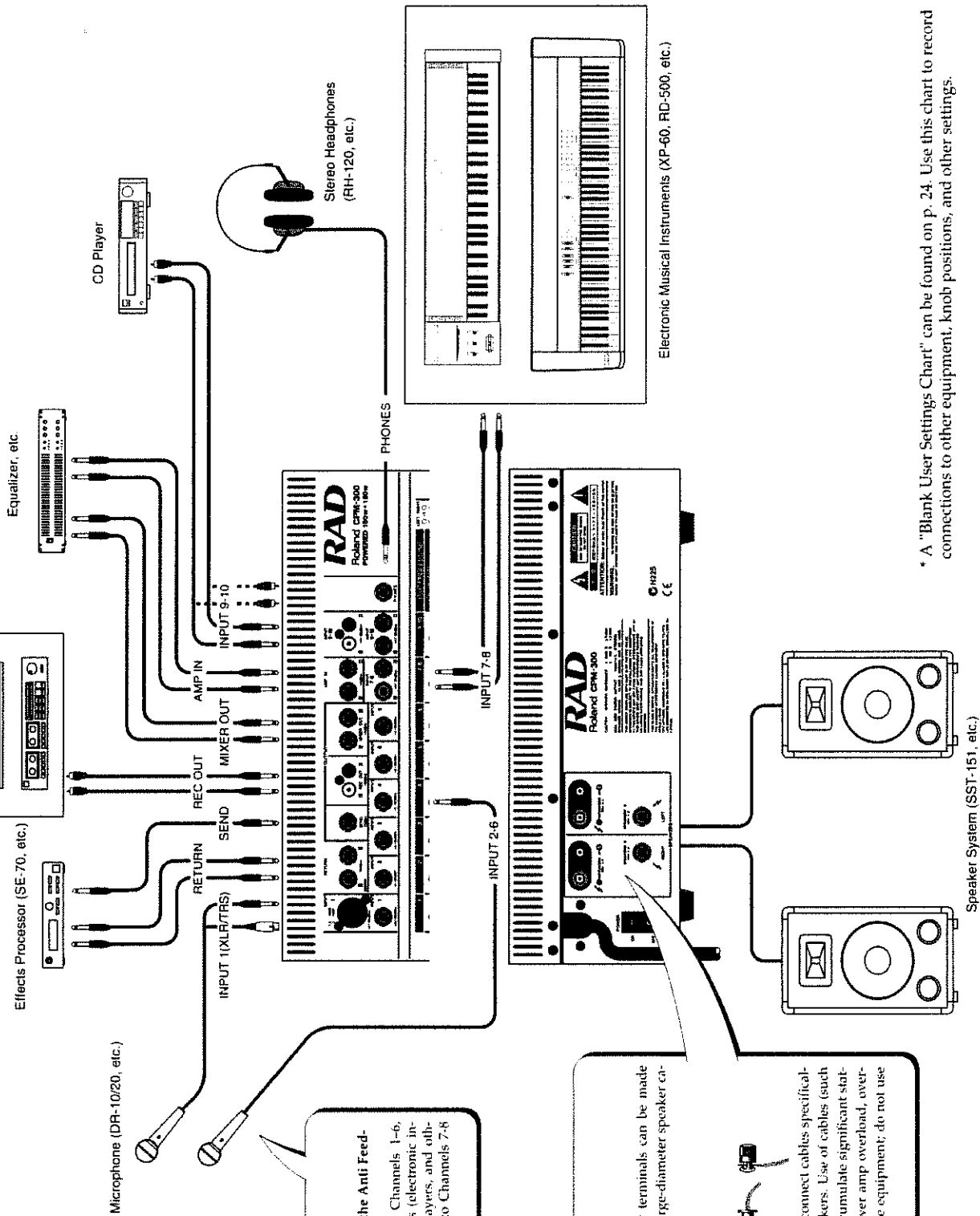

NOTE When Applying the Anti Feedback Function: Connect mics to Channels 1-6, and other devices (electronic instruments, CD players, and other such devices) to Channels 7-8 and 9, 10.

MEMO The binding post speaker terminals can be made using banana plugs and large-diameter speaker cable. However, be sure only to connect cables specifically made for use with speakers. Use of cables (such as shielded cables) that accumulate significant static electricity can cause power amp overload, overheating, and damage to the equipment; do not use such cables.

* A "Blank User Settings Chart" can be found on p. 24. Use this chart to record connections to other equipment, knob positions, and other settings.

Connecting an External Effects Processor or Equalizer

Connect effects processors, equalizers, and other such equipment using the following Jacks.

●SEND/RETURN Jack

Use these jacks when connecting an effects processor to add effects to the source sound.

* This also can be used as an auxiliary input. Mono input is possible by connecting only to the L input.

●MIXER OUT/AMP IN Jack

Use these jacks when connecting devices such as equalizers and compressor/limiters, which alter the sound input to compensate for acoustic and other sonic characteristics. When cables are connected to the AMP IN jacks, the mixer and amplifier sections are separated, and the signal from the mixer section is isolated.

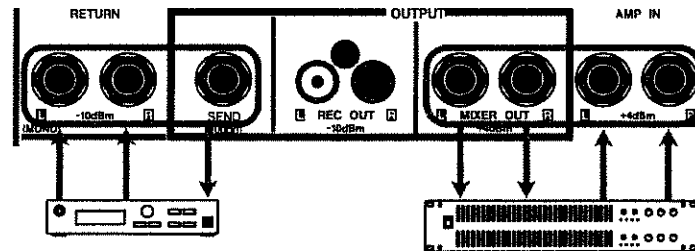

Effects processor to add effects to the source sound

Equalizers and compressor/limiters, which alter the sound input to compensate for acoustic and other sonic characteristics



<MIXER OUT/AMP IN Jack>

In addition to their use in connecting devices such as equalizers and compressor/limiters, the MIXER OUT/AMP IN jacks can also be used in the following circumstances

- When volume levels greater than the CPM-300's internal power amp can provide are needed, connect to an auxiliary power amp and speakers → Connect to MIXER OUT jacks (refer to the figure below).

- When you want to use the CPM-300's power amp only → Connect to AMP IN Jack
Just as with the CPM-300's mixer signal, the amplifier's built-in limiter circuit works to prevent the signal input from the AMP IN jacks from causing distortion and speaker damage.

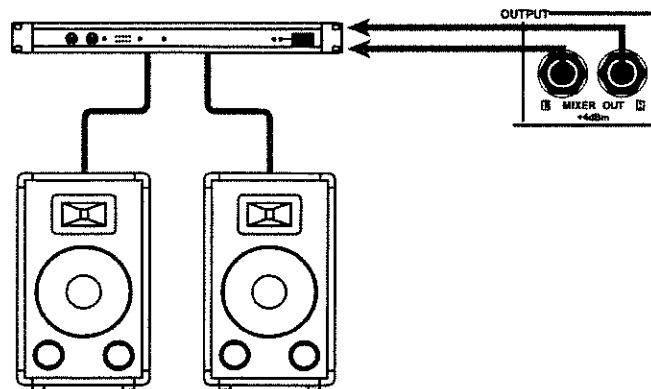

<Using Additional Power Amps and Speakers>

The output from the MIXER OUT jacks can be sent to a separate power amp.

Checking Out the Sound

Precautions When Turning on the Power

- ❑ To protect against malfunction and damage to speakers and other equipment, proceed with the following only after turning down the volume for all devices.
- ❑ Turn each channel's SENS knob completely counterclockwise.
- ❑ Set each channel's EQ knobs to 0 (12 o'clock position).
- ❑ Set each channel's PAN and BAL knobs to the 12 o'clock position.
- ❑ Turn each channel's SEND and RETURN knobs completely counterclockwise.
- ❑ Completely lower all channel faders.

After properly connecting the equipment, switch on the power for each device in sequence, starting with the device producing the sound, or into which the audio signals first enter (reverse the order when shutting off the equipment).

Ex.) CD Player, Synthesizer, etc. → Effects Processor or Other Processing Device → CPM-300

- * Using the improper sequence when turning the equipment on may result in malfunction or damage to speakers or other equipment.
- * After the CPM-300 is switched on, a protection circuit (the Muting Circuit) temporarily prevents the speakers from playing. (For more information about the Muting Circuit → p. 17).

Producing Sound with Microphones (Basic Knobs and Faders Adjustments)

Now, try using a microphone to get some sounds.

1. Connect a microphone to the CPM-300, and rotate the SENS knob slowly clockwise while speaking into the microphone until the PEAK indicator lights up from time to time, then lower the level slightly to set the knob position.
2. Raise the channel fader to the 0 position (in the black range).
3. Adjust the overall volume with the MASTER fader. Adjust the SENS knob again if the PEAK indicator shows that the signal is too hot (strong).
4. Set the sound image for each channel with the PAN and BAL knobs.



The black range along the channel fader and MASTER fader markings indicate the normal range within which you can operate free of distortion or noise.

- * Basic adjustments are the same as those made with CD players and other electronic musical instruments. After making rough adjustments on the connected devices, proceed to "Adjusting the Sound Quality with the Equalizer".

Adjusting the Sound Quality with the Equalizer

The EQ (equalizer) knobs adjust the tone for each channel's input signals. Try rotating the EQ knobs while listening to the sound coming from the speakers (or headphones). At the 0 position, the signal is "flat" (the same as the source sound).

● **HIGH:** This adjusts the tone in the higher frequency range.

With 12 kHz as the center frequency, the volume of the high range can be adjusted 15 dB up or down.

- ◆ Lowering the HIGH EQ cuts the high frequencies, resulting in a milder tone. Lowering this too much creates a tone that is dull and dark.
- ◆ Raising the HIGH EQ boosts the high frequencies, providing a sound that is bright and crisp. Raising this too much creates a sharp, edgy tone.

● **LOW:** This adjusts the tone in the lower frequency range.

Centered on 80 Hz, the volume of the low range can be adjusted 15 dB up or down.

- ◆ Lowering the LOW EQ cuts the low frequencies. Use this technique to improve vocal intelligibility (such as in speeches) in meeting rooms and similar venues.
- ◆ Raising the LOW EQ boosts the low tones. Use this on input from CDs or electronic instruments to give the sound more punch.

After adjusting the sound with the equalizer, proceed to "Adding Reverberation to the Sound (Digital Reverb)" (→ p. 13).

- * A "Blank User Settings Chart" can be found on p. 24. Use this chart to record connections to other equipment, knob positions, and other settings.

Adding Reverberation to the Sound (Digital Reverb)

The CPM-300 offers four types of internal digital reverb.

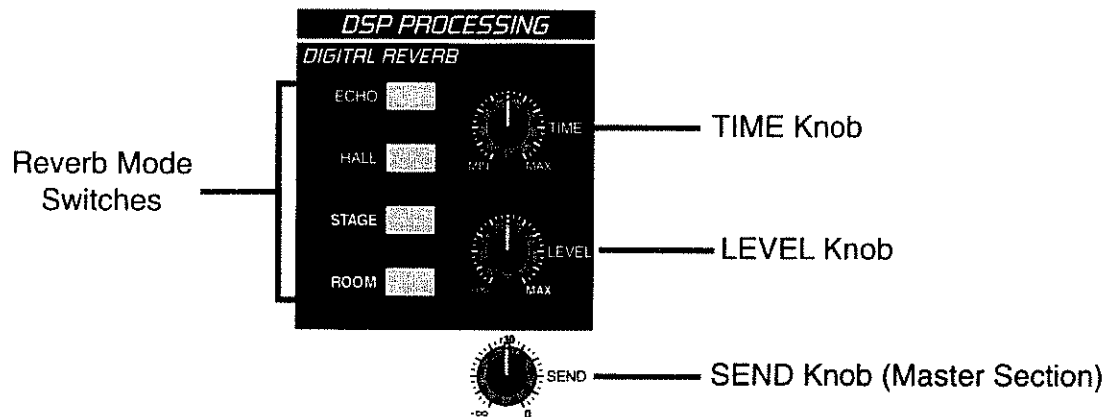

Reverb Mode (Reverb Types)

- **ECHO** :This is an echo effect perfect for karaoke.
- **HALL** :This reverb simulates the reverberation found in concert halls.
- **STAGE** :This simulates the reverberation you hear on a stage.
- **ROOM** :This simulates the reverberation found in smaller rooms.

Operating the Digital Reverb

1. Select the Reverb mode.
 2. Set the SEND knobs to 0 (12 o'clock position) on any channel on which reverb is to be added to the sound.
 3. Rotate the SEND knob (Master Section) to adjust the level of the signal sent to the internal digital reverb.
 4. Rotate the LEVEL knob to adjust the overall reverb level.
 5. Rotate the TIME knob to adjust the reverb time.
 6. Readjust the SENS knobs, SEND knobs, and faders on each channel as needed.
- If you have a mic connected, proceed to "Eliminating Feedback (Anti-Feedback Function)" (→ p. 14).

Eliminating Feedback (Anti-Feedback Function)

Awful, ear-splitting whines and screeching sounds referred to as "feedback" occur when the output from the speakers reenters the microphone, when it is further amplified and then output again, over and over, creating a feedback loop which results in these unpleasant oscillations in the sound. Feedback crops up readily when the mic volume is set too high, or when the mic is pointed at or placed too closed to a speaker.

How to Avoid Feedback

The following describes measures you can take to help prevent feedback from becoming a problem.

- Select the proper output level for the particular room or venue.
- Separate mics and speakers as much as possible, and avoid pointing mics in the direction of the speakers.
- Set the volume levels of connected instruments at appropriate levels.

In actuality, however, feedback may still occur even though you've observed the preventive measures listed above.

Using the CPM-300's Anti-Feedback Function

The CPM-300's built-in "Anti-Feedback Function" is a function that automatically detects feedback the instant it begins, after which the Anti-Feedback Filters then eliminate the feedback. The Anti-Feedback Function feature includes two functions.

● Auto Adjust Function

You can eliminate feedback before your performances by running the Auto Adjust Function during your sound check or rehearsal.

● Dynamic Adjust Function

This function monitors and instantly cuts unexpected feedback during performances.

Procedure for Operating the Auto Adjust Function

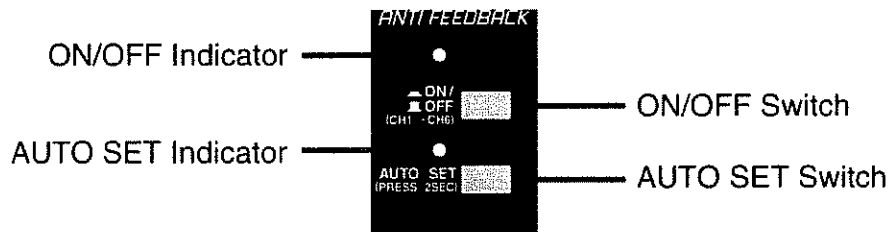

1. Set up microphones at the positions they will be used, then switch them on.
2. Switch the ON/OFF switch to ON.
3. Ready the mixer by raising the faders on channels to which microphones or other inputs are connected, and the MASTER fader to appropriate levels.
4. Hold down the AUTO SET switch for at least two seconds.
The AUTO SET indicator flashes, and while feedback is generated, the point at which the feedback starts is automatically detected, and the feedback is eliminated.
5. The setting is fixed when the AUTO SET indicator changes to steady illumination.

When Quitting Auto Adjust Function During the Procedure

Press the AUTO SET switch. The AUTO SET indicator is illuminated, and the Anti-Feedback Filter settings in effect at that time are stored and retained.

Resetting the Auto Adjust Function from the Beginning

Hold down the AUTO SET switch for at least two seconds. The Anti-Feedback Filter settings in effect up to that time are cleared, and determination of the point at which the feedback starts is begun again.

Notes Regarding the Auto Adjust Function

- Run the Auto Adjust function only after setting up the mics in the positions at which they will be used.
- Do not speak into the mics, or let other sounds enter the mics while the Auto Adjust function is being run.
- Feedback is supposed to occur while the Auto Adjust function is run; this is not abnormal. To avoid disagreeable sound and damage to speakers that can occur with excessive feedback, lower the MASTER faders and the faders for Channels 1–6. The feedback sound is also output through the headphone jack. If you are using headphones, keep the PHONES knob turned completely to the left during the Auto Adjust procedure.
- The Anti-Feedback Filters settings made during Auto Adjust are stored and retained even if the CPM-300's power is turned off. When the power is switched back on, the settings in effect when the power was turned off are recalled.
- The AUTO SET indicator goes out if the Anti-Feedback Filters are not set (have not been used), for example, when the faders are lowered during the Auto Adjust process. When the AUTO SET indicator goes out, and then feedback is no longer eliminated, after resetting each device (raising the CPM-300's faders, turning on mic switches, and so on), run the Auto Adjust function once more.

Dynamic Adjust Function

The Dynamic Adjust Function, which operates continuously whenever the Anti Feedback ON/OFF switch is set to ON, monitors and eliminates any feedback that may suddenly occur during performances. (However, it is not operational while Auto Adjust is in progress).

Common Notes about the Auto Adjust and Dynamic Adjust Functions

- In some cases, due to certain device conditions and settings, feedback may not be completely eliminated.
- The Anti-Feedback functions are effective only on the mono Channels 1–6. Furthermore, the Anti-Feedback functions are not effective on signals from any mono Channel 1–6 that has been routed through the internal digital reverb by means of the channel SEND knobs and MASTER Section's SEND knob.

When Anti-Feedback function cannot eliminate feedback while the internal digital reverb is in use, then with the digital reverb LEVEL knob rotated completely counterclockwise (-infinity: no digital reverb applied), check the following.

- ◆ If feedback is suppressed:

The feedback is caused by the signal sent to the internal digital reverb. The Anti-Feedback function is not applied to this signal. Lower the send levels somewhat with the mono Channel 1–6 SEND knobs and the MASTER SEND knob, and rotate the digital reverb LEVEL knob completely counterclockwise (no digital reverb applied) to prevent feedback from occurring.

- ◆ If feedback is not suppressed:

This feedback cannot be removed with Anti-Feedback function. After redoing the settings for each device, run the Auto Adjust Function once more.

- Switching the Anti Feedback ON/OFF switch to ON sends the signal input to Channels 1–6 to the Anti Feedback. To prevent change in the sound quality of electronic musical instruments, CD players, and other such devices resulting from application of the Anti-Feedback Filters, connect devices other than microphones to Channels 7-8 and 9-10.

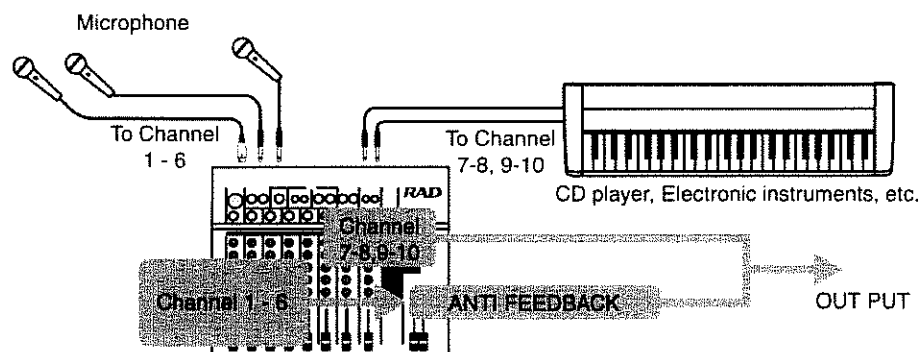

Further Details on the Anti-Feedback Function

How the Removal of Feedback is Achieved

The CPM-300's Anti-Feedback function works by applying narrow-band "filters," called "Anti-Feedback Filters," to the frequencies at which feedback is generated, thus eliminating the feedback by reducing the volume of those frequencies. The CPM-300's Anti-Feedback function features eight separate filters.

With the "Auto Adjust Function," the volume is gradually raised, the intention being to actually cause feedback. It detects the frequencies where feedback occurs, and after the Anti-Feedback Filter settings are finished, the gain is returned to the original level. When the Auto Adjust procedure is finished, margin of gain (called the "safety margin") is maintained, so it keeps working even if conditions change. Six Anti-Feedback Filters are assigned in the Auto Adjust Function.

The "Dynamic Adjust Function," which operates continuously whenever the Anti-Feedback ON/OFF switch is set to ON (except when Auto Adjust is in progress). It monitors the sound for feedback during performances, and eliminates any feedback that may suddenly occur. Two Anti-Feedback Filters are used with the Dynamic Adjust function.

The bandwidth of these eight Anti-Feedback Filters is extremely narrow, so they can suppress feedback while having very little effect on the sound quality.

About the Safety Margin

At the completion of Auto Adjust, a "safety margin" of approximately 12 dB will have been set up. However, during the Auto Adjust procedure, the Auto indicator will begin to flash rapidly as soon as a safety margin of 6 dB has been achieved. This conveniently allows you to stop Auto Adjust while it is in progress, if you believe that a 6 dB margin is sufficient for your needs.

*Auto Adjust ends when all six Anti-Feedback filters are set, even if the approximately 12 dB for the safety margin is not attained.

About the Protection Circuits

The CPM-300 features special circuitry to protect the CPM-300 and any connected devices. Whenever this is activated, the speakers are prevented from producing sound. Stop operation of the equipment, and immediately check to find the problem.

1. Thermal Protection Circuit—Protects the Amp

Speaker output is cut if the temperature of the amp's heat sink exceeds 100 degrees C. Stop operating the equipment for a short while to allow the heat to dissipate sufficiently.

→ Although the unit automatically restarts when the power amp's interior temperature falls, if the overheating protection circuit is activated again, check to make sure that the operating environment and connected output speakers conform to the CPM-300's specifications. Minimum recommended load impedance for the CPM-300's power amp is 4 ohms.

2. DC Detection Circuit—Protects the Speakers

Whenever DC (direct current) is generated in the output sent to the speakers, the output is cut off, protecting the speakers.

→ The CPM-300 restarts a few seconds after generation of direct current in the output ceases.

3. Muting Circuit—Protects the Speakers

When the power is switched on, output to the speakers is cut for a few seconds, thereby protecting the speakers from the sudden noise that occurs when the power is switched on.

Troubleshooting

There is no sound.

- Has the power cord been pulled out of the socket, or is it not seated well? Also check for any shorts in the power cord resulting from a cut or broken cord or from damage to the cord covering.
- Are the channel faders or the MASTER fader lowered? Also check to make sure the channel SENS knobs are not rotated too far counterclockwise.
- Connecting a cable to AMP IN jacks cuts off the signal from the mixer section. When an equalizer or other device is connected, confirm that the MIXER OUT and AMP IN jacks are both securely connected. Check to see if the volume of any device connected between MIXER OUT and AMP IN is turned down. (→ p. 11)
- Is a device with a HOT pin 3 connected to Channel 1? Pin 3 on the CPM-300's Channel 1 is wired to ground. No sound will be produced if pin 3 of the connected device is HOT. The pin assignment for the CPM-300's Channel 1 is shown in the diagram below. Check the pin assignments used by other devices before connecting them.

XLR Type (Unbalanced Input)

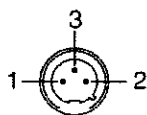

1:GND
2:HOT
3:GND

TRS Standard Phone Type (Unbalanced Input)

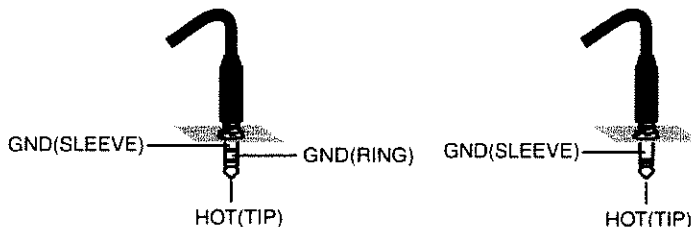

- If the speaker cable's "+" and "-" wires are shorted, or if speakers rated at less than 4 ohms impedance are connected, the PC Limiter Circuit is activated in order to protect the speakers, and the sound may be cut off or distorted. Check to make sure the speaker cables are not shorted and that the speaker impedance is not less than 4 ohms. (PC Limiter Circuit → p. 9)

- The Thermal Protection Circuit cuts off the sound if the internal power amp overheats. Stop operation of the equipment for a while to allow the heat to dissipate sufficiently. Although the unit automatically restarts when the power amp's interior temperature falls, if the Thermal Protection Circuit is activated again, check to make sure that the operating environment and connected speakers conform to the CPM-300's specifications. Minimum recommended load impedance for the CPM-300's power amp is 4 ohms. (Thermal Protection Circuit → p. 17)

- When DC (direct current) is generated in the output sent to the speakers, the DC Detection Circuit cuts off the sound to protect the speakers. The CPM-300 restarts a few seconds after generation of direct current in the output ceases. (DC Detection Circuit → p. 17)

The internal reverb is not working.

- Make sure that the SEND knobs for the channels and the master section to which you want effects applied are not turned counterclockwise.
- Make sure that the DIGITAL REVERB LEVEL knob is not turned counterclockwise.
- Make sure that the faders on the channels to which you want effects applied are not lowered.

Anti-Feedback Function is not working.

- Make sure the ANTI FEEDBACK ON/OFF switch is not set to OFF.
- Anti-Feedback function cannot operate if Anti-Feedback Filters have not been set (AUTO SET indicator extinguished). Check the status of all devices (raise the CPM-300's faders, switch on mics, and so on), then run the Anti-Feedback function's Auto Adjust again.

Feedback cannot be eliminated.

- Moving a microphone after the Anti-Feedback Filter settings are completed creates the chance that feedback will again become a problem. Run the Auto Adjust with mics in the positions where they will be used during the performance.
- If extraneous sound is allowed to enter the mic during the Auto Adjust process, the threshold where feedback begins cannot be properly detected.
- Feedback is supposed to occur during Auto Adjust; this is not abnormal.
- The AUTO SET indicator goes out if the Anti-Feedback Filters are not set (have not been used), for example, when the faders are lowered during the Auto Adjust process. When the AUTO SET indicator goes out, with feedback no longer being eliminated, then after resetting each device (raising the CPM-300's faders, turning on mic switches, and so on), run the Auto Adjust procedure once more.
- The Anti-Feedback functions are effective only on the mono Channels 1–6. Furthermore, the Anti-Feedback functions are not effective on signals from any mono Channel 1–6 that has been routed through the internal digital reverb by means of the channel SEND knobs and MASTER Section's SEND knob.

When Anti-Feedback function cannot eliminate feedback while the internal digital reverb is in use, then with the digital reverb LEVEL knob rotated completely counterclockwise (-infinity: no digital reverb applied), check the following.

- ◆ If feedback is suppressed:
 - The feedback is caused by the signal sent to the internal digital reverb. The Anti-Feedback function is not applied to this signal. Lower the send levels somewhat with the mono Channel 1–6 SEND knobs and the MASTER SEND knob, and rotate the digital reverb LEVEL knob completely counterclockwise (no digital reverb applied) to prevent feedback from occurring.
- ◆ If feedback is not suppressed:
 - This feedback cannot be removed with Anti-Feedback function. After redoing the settings for each device, run the Auto Adjust Function once more.
- In some cases, due to certain device conditions and settings, feedback may not be completely eliminated.

The signal from Channels 1-6 is not output properly

- Switching the Anti Feedback ON/OFF switch to ON sends the signal input to Channel 1–6 to the Anti Feedback. To prevent change in the sound quality of electronic musical instruments, CD players, and other such devices resulting from application of the Anti-Feedback function, connect devices other than microphones to Channels 7-8 and 9-10.

Oscillation in the sound occurs during recording.

- Returning the output of the recording device while recording may cause unwanted oscillations in the sound. During recording, completely lower (set to infinity) the fader for the input channel connected to the output of the recording device.

Specifications

1. Mixer Section

●Frequency Response:

20 Hz—20 kHz -2/+1 dB (Sens : min)

●Total Harmonic Distortion:

0.1 % or less (sens : min, 20 Hz—20 kHz, rated output)

●Noise Level:

(Input 150 W terminated, IHF-A Weighted typ.)

◆Equivalent input Noise Level:

-120 dBm

◆Residual Noise:

-89 dBm (all fader : min)

-72 dBm (master fader : max)

(all channel fader : min)

-72 dBm (master fader : max)

(all channel fader : nominal)

(all sens : min)

-72 dBm (master fader : max)

(all channel fader : nominal)

(all sens : max)

●Crosstalk:

-70 dB or less (1 kHz between channels)

-60 dB or less (1 kHz between L and R)

●Equalizer:

HIGH EQ: ±15 dB (10 kHz shelving type)

LOW EQ: ±15 dB (100 Hz shelving type)

●Digital Reverb:

Sampling Frequency: 48 kHz

Signal Processing: 24 bits

2. Power Amplifier Section

●Rated Output:

100 W x 2 (Stereo, both channels 8 W loaded, 20 Hz—20 kHz,

0.1 % or less THD)

150 W x 2 (Stereo, both channels 4 W loaded, 20 Hz—20 kHz,

0.1 % or less THD)

●Recommended Load Impedance:

4 Ω or greater (STEREO)

●Frequency Response:

20 Hz—20 kHz (±1 dB 1W/8W)

●Total Harmonic Distortion:

0.05 % or less (Stereo, both channels 8 W loaded, 1 kHz, 50 W)

●S/N Ratio:

100 dB or greater (amp in 150 W terminated, IHF-A Weighted)

3. Others

●Power:

AC 117/230/240 V (50/60 Hz)

●Power Consumption:

150 W (AC 117/230/240 V)

●Dimensions:

375 (W) x 307 (D) x 131 (H) mm

14-13/16 (W) x 12-1/8 (D) x 5-3/16 (H) inches

●Weight:

6.0 kg / 13 lb 4 oz

●Accessories:

Owner's Manual

* 0 dBm = 0.775 Vrms

* In the interest of product improvement, the specifications and/or appearance of this unit are subject to change without prior notice.

Input/Output Standards

Input Standard

MIXER SECTION

Input Socket		Input Sensitivity	Rated Input Level	Non-Clip Max. Input Level	Input Impedance	Recommended Source Impedance	Type of Connectors
CHANNEL INPUT	CH1 (SENS=max)	-70 dBm (0.24 mV)	-60 dBm (0.78 mV)	-40 dBm (7.8 mV)	6.3 kΩ	Less than 1 kΩ	XLR-3-31 (Unbalanced) 1/4" TRS PHONE (Unbalanced)
	CH1 (SENS=min)	-6 dBm (388 mV)	+4 dBm (1.23 V)	+24 dBm (12.3 V)			
	CH2 - 6 (SENS=max)	-70 dBm (0.24 mV)	-60 dBm (0.78 mV)	-40 dBm (7.8 mV)	6.3 kΩ	Less than 1 kΩ	1/4" PHONE
	CH2 - 6 (SENS=min)	-6 dBm (388 mV)	+4 dBm (1.23 V)	+24 dBm (12.3 V)			
STEREO CHANNEL INPUT	CH7 - 10 (SENS=max)	-30 dBm (24.5 mV)	-20 dBm (77.5 mV)	0 dBm (775 mV)	8.3 kΩ	Less than 1 kΩ	1/4" PHONE
	CH7 - 10 (SENS=min)	+14 dBm (3.88 V)	+4 dBm (1.23 V)	+24 dBm (12.3 V)			RCA PHONO (CH 9-10)
RETURN	RTN	0 dBm (775 mV)	-10 dBm (245 mV)	+10 dBm (2.45 V)	12 kΩ (STEREO) 6 kΩ (MONO)	Less than 2 kΩ (STEREO) Less than 1 kΩ (MONO)	1/4" PHONE

POWER AMP SECTION

Input Socket	Input Sensitivity	Input Impedance	Recommended Source Impedance	Type of Connectors
AMP IN	+4 dBm (1.23 V)	11 kΩ	Less than 2 kΩ	1/4" PHONE

Output Standard

MIXER SECTION

Output Socket	Rated Output Level	Non-Clip Max. Output Level	Output Impedance	Recommended Source Impedance	Type of Connectors
MIXER OUT	+4 dBm (1.23 V)	+20 dBm (7.75 V)	400 Ω	More than 4 kΩ	1/4" PHONE
SEND	-10 dBm (245 mV)	+20 dBm (7.75 V)	400 Ω	More than 4 kΩ	1/4" PHONE
REC OUT	-10 dBm (245 mV)	+20 dBm (7.75 V)	2 kΩ	More than 10 kΩ	RCA PHONO
PHONES	-----	100 mW + 100 mW *1	100 Ω	More than 8 Ω	1/4" TRS PHONE

POWER AMP SECTION

Output Socket	Rated Output	Non-Clip Max. Output Level	Recommended Source Impedance	Type of Connectors
SPEAKERS OUT	STEREO 150 W *2	24.5 Vrms (4 Ω) 28.3 Vrms (8 Ω)	Less than 4 Ω	BINDING POST 1/4" PHONE

@0 dBm = 0.775 Vrms

*1: Both Channels 100 Ω Loaded

*2: Both Channels 4 Ω Loaded

Block Diagram

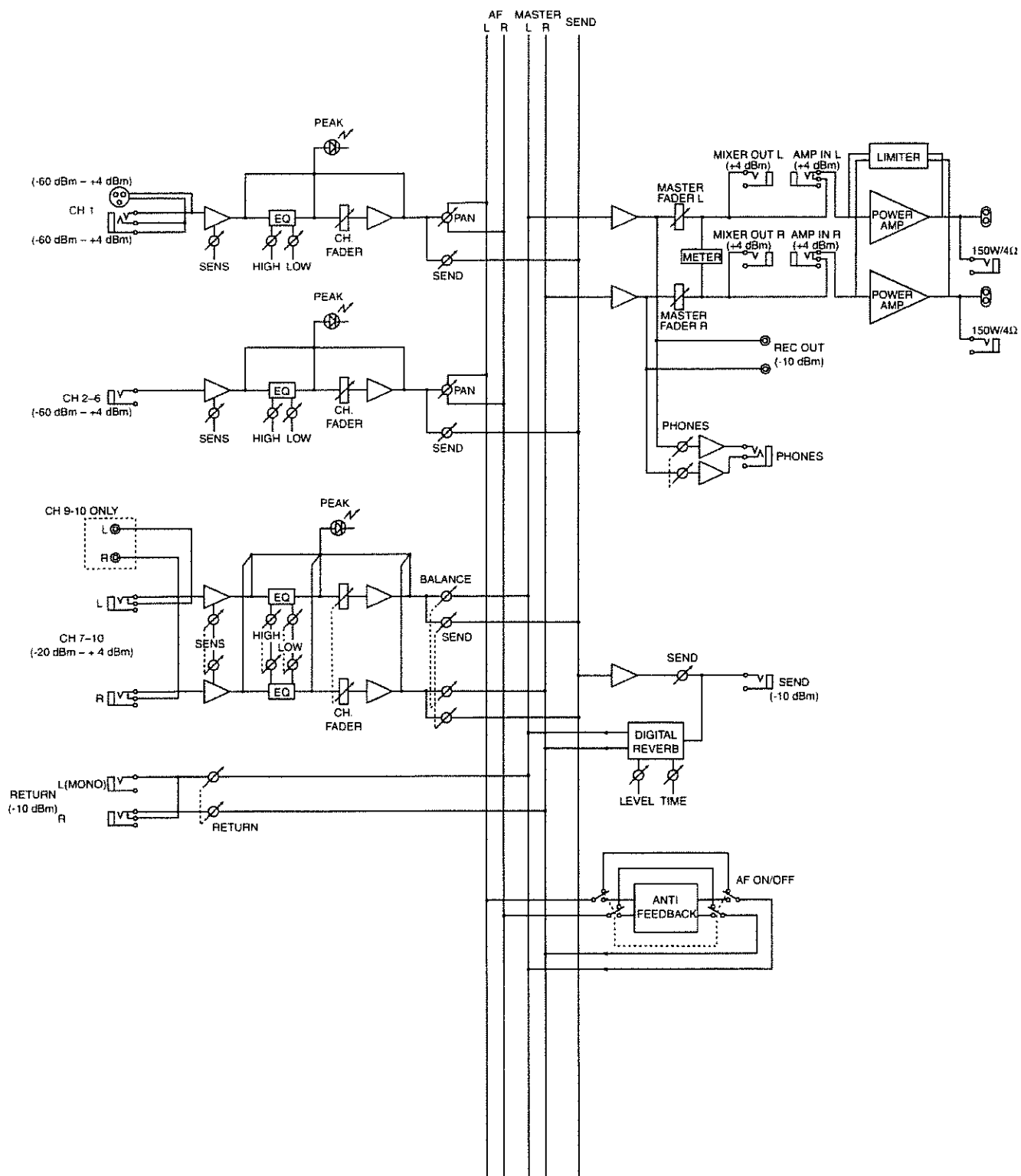

Dimensions

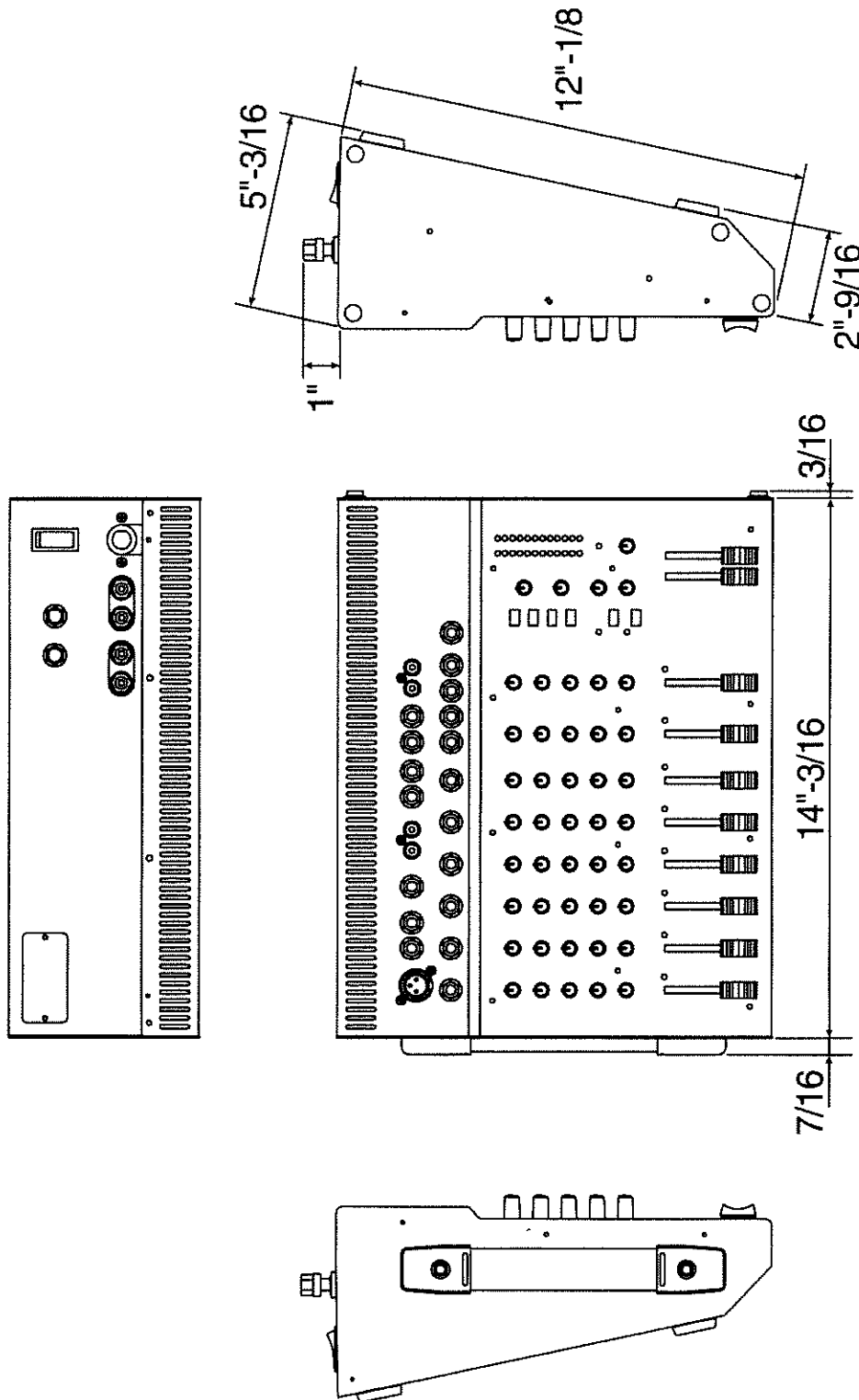

Blank User Settings Chart

Copy this, then use it to jot down your settings.

The diagram shows the physical layout of the Roland CPM-300 control panel. It includes sections for:

- INPUTS:** 1-3 (MONO), 1-6 (STEREO), 7-8 (STEREO), 9-10 (STEREO).
- RETURN:** MONO and STEREO inputs.
- OUTPUT:** SEND, REC OUT, MIXER OUT.
- AMP IN:** INPUT 7-8 and 9-10.
- PHONES:** A dedicated output jack.

RAD

Roland CPM-300
POWERED 150w + 150w

1		2		3		4		5		6		7-8		9-10		DSP PROCESSING		LEFT RIGHT	
SENS		SENS		SENS		SENS		SENS		SENS		SENS		SENS		DIGITAL REVERB		0	
HIGH		HIGH		HIGH		HIGH		HIGH		HIGH		HIGH		HIGH		STAGE		-10	
LOW		LOW		LOW		LOW		LOW		LOW		LOW		LOW		ROOM		-20	
SEND		SEND		SEND		SEND		SEND		SEND		SEND		SEND		ANTI FEEDBACK		POWER	
PAN		PAN		PAN		PAN		PAN		PAN		BAL		BAL		ON/OFF		PHONES	
LEFT		RIGHT		LEFT		RIGHT		LEFT		RIGHT		LEFT		RIGHT		AUTO SET		MAX	
PEAK		PEAK		PEAK		PEAK		PEAK		PEAK		PEAK		PEAK		MASTER		LEFT	
0-10		0-10		0-10		0-10		0-10		0-10		0-10		0-10		0-10		RIGHT	
0-40		0-40		0-40		0-40		0-40		0-40		0-40		0-40		0-40		0-40	

Index

AMP IN	8,10,11	POWER Switch	9
ANTI FEEDBACK	7,14,15,16	Protection Circuits	17
Anti-Feedback Function	14,15,16	Rear Panel	9
Anti-Feedback Filter	14,15,16	Recommended Load Impedance	9
Auto Adjust Function	14,15,16	REC OUT Jack	8,10
AUTO SET Indicator (ANTI FEEDBACK)	14,15,16	RETURN Jack	8,10,11
AUTO SET Switch (ANTI FEEDBACK)	14	Reverb Mode	13
BAL (Balance) Knob	6,12	ROOM (DIGITAL REVERB)	13
Banana Plug	10	RTN(Return) Knob	7
Binding Post	9,10	Safety Margin	16
Block Diagram	22	SEND Jack	8,10,11
Channel Fader	7,12	SEND/RETURN Jack	8,10,11
DC Detection Circuit	17	SEND Knob (Channel Section)	6,13,15
DIGITAL REVERB	7,13	SEND Knob (Master Section)	7,13,15
DSP PROCESSING	7	Side Panel	9
Dynamic Adjust Function	15	Speaker Connection Terminals	9,10
ECHO (DIGITAL REVERB)	13	STAGE (DIGITAL REVERB)	13
EQ	6,12	Thermal Protection Circuit	17
EQ (Equalizer) Knob	6,12	TIME Knob (DIGITAL REVERB)	13
Equalizer	6,11,12		
Front Panel	6		
HALL (DIGITAL REVERB)	13		
Handle	9		
HIGH (EQ)	12		
INPUT			
RCA Phono Type	8		
RETURN	8,10,11		
Standard Phone Type	8		
TRS Standard Phone Type	8		
XLR Type	8		
LEVEL Knob (DIGITAL REVERB)	13		
LOW (EQ)	12		
MASTER Fader	7,12		
MASTER LEVEL Meter	7		
MIXER OUT/ AMP IN Jack	8,10,11		
Muting Circuit	17		
ON/OFF Indicator (ANTI FEEDBACK)	14		
ON/OFF Switch (ANTI FEEDBACK)	14,15,16		
OUTPUT			
AMP IN	8,10,11		
MIXER OUT	8,10,11		
PHONES	8,10,11		
REC OUT	8,10		
SEND	8,10,11		
Speaker Connection Terminals	9,10		
PAN (Panpot) Knob	6,12		
PC Limiter Circuit	9		
PEAK Indicator	7,12		
PHONES Jack	8,10		
PHONES Knob	7,15		
POWER Indicator	7		

Information

When you need repair service, call your nearest Roland Service Center or authorized Roland distributor in your country as shown below.

ARGENTINA

Instrumentos Musicales S.A.
Florida 638
(1005) Buenos Aires
ARGENTINA
TEL: (01) 394 4029

BRAZIL

Roland Brasil Ltda.
R. Coronel Octaviano da Silveira
203 05522-010
Sao Paulo BRAZIL
TEL: (011) 843 9377

CANADA

Roland Canada Music Ltd.
(Head Office)
5480 Parkwood Way Richmond
B. C. V6V 2M4 CANADA
TEL: (604) 270 6026

Roland Canada Music Ltd.
(Toronto Office)

Unit 2, 109 Woodbine Downs
Blvd. Etobicoke, ON
M9W 6Y1 CANADA
TEL: (416) 213 9707

MEXICO

Casa Veerkamp, s.a. de c.v.
Av. Toluca No. 323 Col. Olivar de
los Padres 01780 Mexico D.F.
MEXICO
TEL: (525) 668 04 80

**La Casa Wagner de
Guadalajara s.a. de c.v.**
Av. Corona No. 202 S.J.
Guadalajara, Jalisco Mexico
C.P. 44100 MEXICO
TEL: (03) 613 1414

PANAMA

Productos Superiores, S.A.
Apartado 655 - Panama 1
REP. DE PANAMA
TEL: 26 3322

U. S. A.

Roland Corporation U.S.
7200 Dominion Circle
Los Angeles, CA 90040-3696,
U. S. A.
TEL: (213) 685 5141

VENEZUELA

Musiland Digital C.A.
Av. Francisco de Miranda,
Centro Parque de Cristal, Nivel
C2 Local 20 Caracas
VENEZUELA
TEL: (02) 285 9218

AUSTRALIA

**Roland Corporation
Australia Pty. Ltd.**
38 Campbell Avenue
Dee Why West, NSW 2099
AUSTRALIA
TEL: (02) 9982 8266

NEW ZEALAND

Roland Corporation (NZ) Ltd.
97 Mt. Eden Road, Mt. Eden,
Auckland 3, NEW ZEALAND
TEL: (09) 3098 715

CHINA

**Beijing Xinghai Musical
Instruments Co., Ltd.**
6 Huangmunchang Chao Yang
District, Beijing, CHINA
TEL: (010) 6774 7491

HONG KONG

Tom Lee Music Co., Ltd.
Service Division
22-32 Fun Shan Street, Tsuen
Wan, New Territories,
HONG KONG
TEL: 2415 0911

INDIA

Rivera Traders Pvt. Ltd.
409, Nirman Kendra,
off De. Edwin Moses Road,
Mumbai 400011, INDIA
TEL: (022) 498 3079

INDONESIA

PT Galestra Inti
Kompleks Perkantoran
Duta Merlin Blok E No.6-7
Jl. Gajah Mada No.3-5,
Jakarta 10130,
INDONESIA
TEL: (021) 6335416

KOREA

**Cosmos Corporation
Service Station**
201 2nd Floor Nak-Won Arcade
Jong-Ro ku, Seoul, KOREA
TEL: (02) 742 8844

MALAYSIA

Bentley Music SDN BHD
140 & 142, Jalan Bukit Bintang
55100 Kuala Lumpur, MALAYSIA
TEL: (03) 2443333

PHILIPPINES

G.A. Yupango & Co. Inc.
339 Gil J. Puyat Avenue
Makati, Metro Manila 1200,
PHILIPPINES
TEL: (02) 899 9801

SINGAPORE

Sweet Lee Company
BLOCK 231, Bain Street #03-23
Bras Basah Complex,
SINGAPORE 180231
TEL: 3367886

CRISTOFORI MUSIC PTE LTD

Blk 3014, Bedok Industrial Park E,
#02-2148, SINGAPORE 489980
TEL: 243 9555

TAIWAN

**ROLAND TAIWAN
ENTERPRISE CO., LTD.**
Room 5, 9th, No. 112 Chung Shan
N. Road Sec.2, Taipei, TAIWAN,
R.O.C.
TEL: (02) 2561 3339

THAILAND

Theera Music Co., Ltd.
330 Veeng Nakorn Kasem, Soi 2,
Bangkok 10100, THAILAND
TEL: (02) 2248821

VIETNAM

Saigon music distributor
160 Nguyen Dinh Chieu St. Dist 3
Ho chi minh City
VIETNAM
TEL: 88-242531

BAHRAIN

Moon Stores
Bab Al Bahrain Road,
P.O.Box 20077
State of BAHRAIN
TEL: 211 005

ISRAEL

**Halilit P. Greenspoon &
Sons Ltd.**
8 Retzif F'alayia Hashnya St
Tel-Aviv-Yahel ISRAEL
TEL: (03) 682366

JORDAN

AMMAN Trading Agency
Prince Mohammed St. P. O. Box
825 Amman 13118 JORDAN
TEL: (06) 641200

KUWAIT

Easa Husain Al-Yousiff
P.O. Box 126 Safat 13002
KUWAIT
TEL: 5719499

LEBANON

A. Chahine & Fils
P.O. Box 16-5857 Gergi Zeidan St.
Chahine Building, Achrafieh
Beirut, LEBANON
TEL: (01) 335799

OMAN

**OHI Electronics & Trading
Co. LLC**
P. O. Box 889 Muscat
Sultanate of OMAN
TEL: 959085

QATAR

Badie Studio & Stores
P.O.Box 62,
DOHA QATAR
TEL: 423554

SAUDI ARABIA

**Abdul Latif S. Al-Ghamdi
Trading Establishment**
Middle East Commercial Center
Al-Khobar Dharan Highway
P.O. Box 3631 Al-Khobar
31952 SAUDI ARABIA
TEL: (03) 898 2332

aDawiah Universal

Electronics APL
P.O.Box 2154 ALKHOBAR 31952,
SAUDI ARABIA
TEL: (03) 898 2081

SYRIA

**Technical Light & Sound
Center**
Khaled Ibn Al Walid St.
P.O.Box 13520
Damascus - SYRIA
TEL: (011) 2235 384

TURKEY

**Barkat Musik aletleri ithalat
ve ihracat limited ireketi**
Siraselvler Cad. Gurey Ishtani No.
86/6 Taksim, Istanbul TURKEY
TEL: (0212) 2499324

U.A.E

**Zak Electronics & Musical
Instruments Co.**
Zabeel Road, Al Sherouq Bldg.,
No. 14, Grand Floor DUBAI
U.A.E.
P.O. Box 8050 DUBAI, U.A.E
TEL: (04) 360715

EGYPT

Al Fanny Trading Office
P.O.Box 2904,
El Horrieh Heliopolis, Cairo,
EGYPT
TEL: (02) 4171828
(02) 4185531

KENYA

Musik Land Limited
P.O. Box 12183 Moi Avenue
Nairobi Republic of KENYA
TEL: (2) 338 346

REUNION

Maison FO - YAM Marcel
25 Rue Jules MermanZL
Chaudron - 9779 97491
Ste Clotilde REUNION
TEL: 28 29 16

SOUTH AFRICA

**That Other Music Shop
(PTY) Ltd.**
11 Melke Street (Cnr Melle and
Juta Street)
Braamfontein 2001
Republic of SOUTH AFRICA
TEL: (011) 403 4105

Paul Bothner (PTY) Ltd.

17 Werdmuller Centre Claremont
7700
Republic of SOUTH AFRICA
TEL: (021) 64 4030

AUSTRIA

E. Dematte & Co.
Neu-Rum Siemens-Strasse 4
6063 Innsbruck AUSTRIA
TEL: (0512) 26 44 260

BELGIUM/HOLLAND/ LUXEMBOURG

Roland Benelux N. V.
Houtstraat 3 B-2260 Oevel
(Western) BELGIUM
TEL: (014) 575811

BELORUSSIA

TUSHE
UL. Rabkarovskaya 17
220001 MINSK
TEL: (0172) 764-911

CYPRUS

Radex Sound Equipment Ltd.
17 Diagotou St., P.O.Box 2046,
Nicosia CYPRUS
TEL: (02) 453 426

DENMARK

Roland Scandinavia A/S
Langebrogade 6 Post Box 1937
DK-1023 Copenhagen K
DENMARK
TEL: 32 95 3111

FRANCE

Roland France SA
4, Rue Paul Henri SPAAK
Parc de l'Esplanade F 77 462 St.
Thibault Lagny Cedex FRANCE
TEL: 01 600 73 508

FINLAND

**Roland Scandinavia As,
Filial Finland**
Lautasaarentie 54 B
Fin-00201 Helsinki, FINLAND
TEL: (9) 682 4020

GERMANY

**Roland Elektronische
Musikinstrumente
Handelsgesellschaft mbH.**
Oststrasse 96, 22844 Norderstedt,
GERMANY
TEL: (040) 52 60090

GREECE

V. Dimitriadis & Co. Ltd.
20, Alexandras St. & Boutoulinas
54 St. 106 82 Athens, GREECE
TEL: (01) 8232415

HUNGARY

Intermusica Ltd.
Warehouse Area 'DEPO' P/83
H-2046 Torokbalint, HUNGARY
TEL: (23) 511011

IRELAND

**The Dublin Service Centre
Audio Maintenance Limited**
11 Brunswick Place Dublin 2
Republic of IRELAND
TEL: (01) 677322

ITALY

Roland Italy S. p. A.
Viale Jelle Industrie, 8
20020 Arese Milano, ITALY
TEL: (02) 937 781

NORWAY

**Roland Scandinavia Avd.
Kontor Norge**
Lilleakerveien 2 Postboks 95
Lilleaker N-0216 Oslo
NORWAY
TEL: 273 0074

POLAND

P. P. H. Brzostowicz Marian
UL. Blokowa 32, 03024 Warszawa
POLAND
TEL: (022) 679 44 19

PORTUGAL

**Caius - Tecnologias Audio e
Musica , Lda.**
Rue de SANTA Catarina 131
4000 Porto, PORTUGAL
TEL: (02) 38 4456

RUSSIA

Slami Music Company
Sadovaya-Triumfalnaja st., 16
103006 Moscow, RUSSIA
TEL: (095) 209 2193

SPAIN

**Roland Electronics
de España, S. A.**
Calle Bolivia 239 08020 Barcelona,
SPAIN
TEL: (93) 308 1000

SWEDEN

**Roland Scandinavia A/S
SWEDISH SALES OFFICE**
Danvik Center 26, 2 tr.
S-131 30 Nacka SWEDEN
TEL: (08) 702 0020

SWITZERLAND

**Roland (Switzerland) AG
Musitronic AG**
Gerberstrasse 5, CH-4410 Laetal,
SWITZERLAND
TEL: (061) 921 1615

UKRAINE

TIC-TAC
Mira Str. 19/108
P.O.Box 180
295400 Mukachevo, UKRAINE
TEL: (03131) 414-40

UNITED KINGDOM

**Roland (U.K.) Ltd., Swansea
Office**
Atlantic Close, Swansea
Enterprise Park SWANSEA
West Glamorgan SA7 9FL,
UNITED KINGDOM
TEL: (01792) 700139



For EU Countries

This product complies with the requirements of European Directives EMC 89/336/EEC and LVD 73/23/EEC.

For the USA

FEDERAL COMMUNICATIONS COMMISSION RADIO FREQUENCY INTERFERENCE STATEMENT

This equipment has been tested and found to comply with the limits for a Class B digital device, pursuant to Part 15 of the FCC Rules. These limits are designed to provide reasonable protection against harmful interference in a residential installation. This equipment generates, uses, and can radiate radio frequency energy and, if not installed and used in accordance with the instructions, may cause harmful interference to radio communications. However, there is no guarantee that interference will not occur in a particular installation. If this equipment does cause harmful interference to radio or television reception, which can be determined by turning the equipment off and on, the user is encouraged to try to correct the interference by one or more of the following measures:

- Reorient or relocate the receiving antenna.
- Increase the separation between the equipment and receiver.
- Connect the equipment into an outlet on a circuit different from that to which the receiver is connected.
- Consult the dealer or an experienced radio/TV technician for help.

Unauthorized changes or modification to this system can void the users authority to operate this equipment.
This equipment requires shielded interface cables in order to meet FCC class B Limit.

For Canada

NOTICE

This Class B digital apparatus meets all requirements of the Canadian Interference-Causing Equipment Regulations.

AVIS

Cet appareil numérique de la classe B respecte toutes les exigences du Règlement sur le matériel brouilleur du Canada.

Roland®

G6017274

UPC

G6017274



10981

Roland®