

Roland®



Roland Organ ATELIER

---

AT70/50

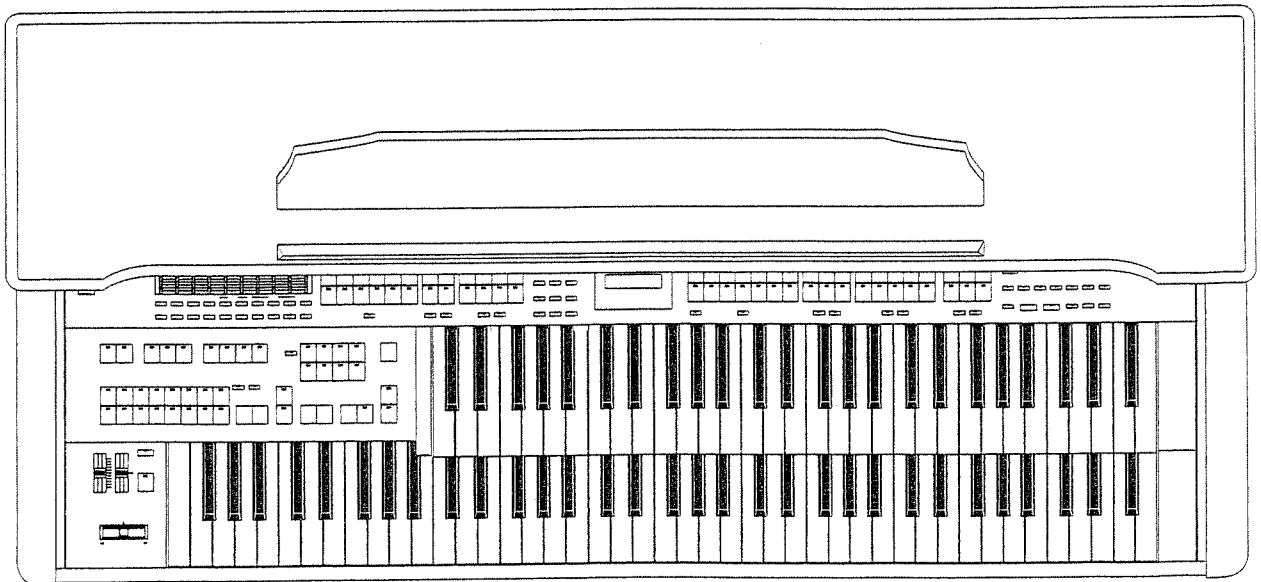
OWNER'S MANUAL



	<b>CAUTION</b> RISK OF ELECTRIC SHOCK DO NOT OPEN	
<b>ATTENTION:</b> RISQUE DE CHOC ELECTRIQUE NE PAS QUVRIR		
<b>CAUTION:</b> TO REDUCE THE RISK OF ELECTRIC SHOCK, DO NOT REMOVE COVER (OR BACK). NO USER-SERVICEABLE PARTS INSIDE. REFER SERVICING TO QUALIFIED SERVICE PERSONNEL.		



The lightning flash with arrowhead symbol, within an equilateral triangle, is intended to alert the user to the presence of uninsulated "dangerous voltage" within the product's enclosure that may be of sufficient magnitude to constitute a risk of electric shock to persons.



The exclamation point within an equilateral triangle is intended to alert the user to the presence of important operating and maintenance (servicing) instructions in the literature accompanying the product.

**INSTRUCTIONS PERTAINING TO A RISK OF FIRE, ELECTRIC SHOCK, OR INJURY TO PERSONS.**

## IMPORTANT SAFETY INSTRUCTIONS

### SAVE THESE INSTRUCTIONS

**WARNING** - When using electric products, basic precautions should always be followed, including the following:

1. Read all the instructions before using the product.
2. Do not use this product near water — for example, near a bathtub, washbowl, kitchen sink, in a wet basement, or near a swimming pool, or the like.
3. This product should be used only with a cart or stand that is recommended by the manufacturer.
4. This product, either alone or in combination with an amplifier and headphones or speakers, may be capable of producing sound levels that could cause permanent hearing loss. Do not operate for a long period of time at a high volume level or at a level that is uncomfortable. If you experience any hearing loss or ringing in the ears, you should consult an audiologist.
5. The product should be located so that its location or position does not interfere with its proper ventilation.
6. The product should be located away from heat sources such as radiators, heat registers, or other products that produce heat.
7. The product should be connected to a power supply only of the type described in the operating instructions or as marked on the product.
8. The power-supply cord of the product should be unplugged from the outlet when left unused for a long period of time.
9. Care should be taken so that objects do not fall and liquids are not spilled into the enclosure through openings.
10. The product should be serviced by qualified service personnel when:
  - A. The power-supply cord or the plug has been damaged; or
  - B. Objects have fallen, or liquid has been spilled onto the product; or
  - C. The product has been exposed to rain; or
  - D. The product does not appear to operate normally or exhibits a marked change in performance; or
  - E. The product has been dropped, or the enclosure damaged.
11. Do not attempt to service the product beyond that described in the user-maintenance instructions. All other servicing should be referred to qualified service personnel.

For the USA

This product may be equipped with a polarized line plug (one blade wider than the other) . This is a safety feature. If you are unable to insert the plug into the outlet, contact an electrician to replace your obsolete outlet. Do not defeat the safety purpose of the plug.

For Canada

For Polarized Line Plug

**CAUTION:** TO PREVENT ELECTRIC SHOCK, MATCH WIDE BLADE OF PLUG TO WIDE SLOT, FULLY INSERT.

**ATTENTION:** POUR ÉVITER LES CHOCs ÉLECTRIQUES, INTRODUIRE LA LAME LA PLUS LARGE DE LA FICHE DANS LA BORNE CORRESPONDANTE DE LA PRISE ET POUSSER JUSQU' AU FOND.

For the U.K.

**IMPORTANT:** THE WIRES IN THIS MAINS LEAD ARE COLOURED IN ACCORDANCE WITH THE FOLLOWING CODE.

BLUE	: NEUTRAL
BROWN	: LIVE

As the colours of the wires in the mains lead of this apparatus may not correspond with the coloured markings identifying the terminals in your plug, proceed as follows:

The wire which is coloured BLUE must be connected to the terminal which is marked with the letter N or coloured BLACK.  
The wire which is coloured BROWN must be connected to the terminal which is marked with the letter L or coloured RED.

## Concerning the procedures in Chapter 8, "Other Kinds of Settings"

Note that after any of the five buttons listed below have been pressed, you will need to either press the same button a second time, or press the Display/Exit button in order to get back to the basic screen.

### These buttons:

Utility  
Effect  
Oct Shift  
Transpose  
Function

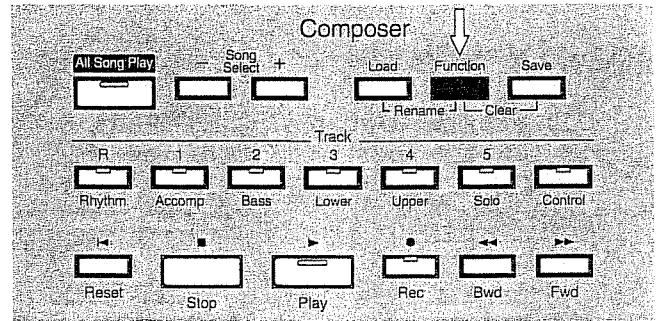
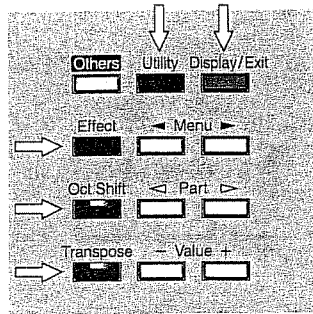

### ■ Concerning Settings Made with the Utility and Effect Buttons .....

Whenever the indicator on the Rec button is lit, you won't be able to make any of the settings that ordinarily can be made using the Utility and Effect Buttons.

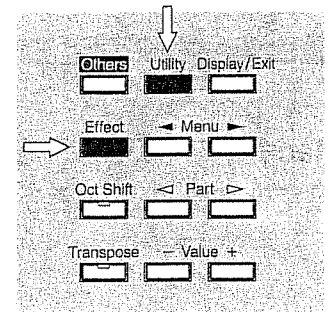

### ■ Concerning Settings Made with the Others Buttons .....

- Such settings cannot be made while playing or recording performance data.
- Whenever you expect that you will want to use the Others buttons to change the sound while you have a rhythm or rhythm + automatic accompaniment playing, you should press the Others Button before starting play of the rhythm or automatic accompaniment. Note also that if you return to a basic screen after making the change, the rhythm or automatic accompaniment will stop playing.

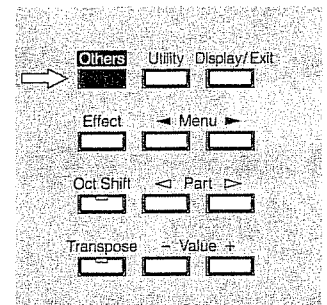

## CORRECTIONS

The following corrections should bring the OWNER'S MANUAL up-to-date.

### Page 78, "MIDI Imprementation Chart"

Basic Channel (Transmitted)

(error) 11, 12, 13 (correct) 12, 13, 14

### Page 80, "Power Consumption"

(error) AT-70 : 377W (AC117V) (correct) AT-70 : 400W (AC117V)



Thank you, and congratulations on your choice of the Roland AT-70/50 "Atelier Series" Organ. The AT-70/50 is an electronic organ which provides a generous collection of luscious organ sounds. In addition, it is designed to be easy to learn and use.

In order to take full advantage of the wealth of features that have been made available, please take the time to read this manual in its entirety.

## FEATURES

### ● Comes With a Rich Variety of Organ Sounds (Voices)

Offers a total of 128 different Voices. These include a variety of instrument sounds (such as strings and piano), in addition to the essential selection of 40 organ sounds that it contains. The instrument allows you to layer up to three Voices together for both the Upper and Lower keyboards, and also make use of an additional Solo Voice. Additionally, it is equipped with a GS compatible sound generator, which can be used for playing automatic accompaniment as well as music data on disk (such as commercially available "SMF Music Data.")

### ● Can Produce Even the Most Complex Ensembles

You can enjoy playing along with a rhythm instrument backing, since there are 64 different Rhythms contained in the AT-70/50. In addition, the instrument provides an Arranger feature which produces an automatic accompaniment. All you need to do is specify a chord using the Lower keyboard. By acquiring Cards (available separately), you can also add new Rhythms to your repertoire.

### ● Easy-To-Learn Buttons

All the buttons are over-sized and are logically arranged according to function to make the instrument easy to use. Moreover, the One Touch Program button conveniently allows you to instantaneously make the settings for a Rhythm and automatic accompaniment.

### ● Provides Stunning, High-Quality Sound

These models were designed to accommodate performances in concert halls and lounges. The AT-70 is equipped with a 240 watt, three channel amplifier/seven speaker sound system. The AT-50 comes with a 160 watt, three channel amplifier/five speaker sound system. You can thus be assured of powerful, high-quality sound.

### ● Ready For Any Performance Situation

The keyboard has 76 keys (61 on the AT-50), so it is ideal for piano music as well. To enhance your expressive capabilities, it also includes a damper pedal and pitch bend/vibrato lever.

### ● The Onboard "Composer" Is As Easy To Use As a Tape Recorder

The Composer unit that has been included allows you to record what you play, much like making recordings on a tape recorder. You can also use it to play commercially available SMF Music Data.

### ● C High-Class Design

A walnut finish gives the instrument a traditional, dignified look.

---

Copyright © 1994 ROLAND CORPORATION

All rights reserved. No part of this publication may be reproduced in any form without the written permission of ROLAND CORPORATION.

# TABLE OF CONTENTS

IMPORTANT NOTES .....	7
PANEL DESCRIPTIONS .....	8
BEFORE YOU BEGIN .....	14

## **CHAPTER 1 Introduction**

---

■ Turning On Power .....	15
■ Adjusting the Volume .....	15
■ Restoring All the Factory Default Settings .....	16

## **CHAPTER 2 How To Select Voices**

---

■ Upper and Lower .....	17
■ Pedal Bass Part .....	18
■ Solo Part .....	19
■ How to Use the Others Buttons .....	20
■ Drums and Sound Effects .....	22

## **CHAPTER 3 Selection of Effects**

---

■ Chorus Effect .....	23
■ Reverb Effect .....	24
■ Sustain Effect .....	24
■ Rotary Effect .....	25
■ Pitch Bend and Vibrato Effects .....	26
■ Using the Brilliance Slider to Adjust Timbre .....	26
■ Adding Harmony to Melodies (Melody Intelligence Button) .....	27
■ Adjusting Overall Volume Using the Expression Pedal .....	27
■ Foot Switches .....	28
■ Damper Pedal .....	28

## **CHAPTER 4 Rhythms**

---

■ How to Select a Rhythm .....	29
● How to Use the Others Button .....	30
■ Using a Music Style Card .....	31
■ Starting/Stopping Rhythms .....	32
● Using the Sync Start Function .....	32
■ Altering the Tempo of a Rhythm .....	33
■ Applying Change to a Rhythm .....	34
● Changing a Rhythm's Arrangement (Variation Button) .....	34
● Inserting a Fill-In (To Original Button/To Variation Button) .....	34
● Inserting Empty Measures (Break Button) .....	34

■ Adding Automatic Accompaniment to Rhythm Performances .....	35
● Easy Preparation For Automatic Accompaniment (One Touch Program Button) ...	35
● Switching Automatic Accompaniment On/Off (Arranger On/Off Button) .....	35
● Inserting an Intro (Intro/Ending Button) .....	36
● Inserting an Ending (Intro/Ending Button).....	36
● Changing the Automatic Accompaniment Arrangement (Advanced Button) ....	36
● Using Easy Fingering to Play Chords (Chord Intelli Button) .....	37
● Leading Bass Function (Leading Bass Button).....	38
● Sustaining Notes Played on the Lower Keyboard (Lower Voice Hold Button) ...	38

## **CHAPTER 5 Storing Panel Settings (Registration)**

---

■ Storing Registrations .....	39
■ How To Call Up Settings.....	39
■ How to Use the Manual Button .....	39
■ Saving Registrations on Floppy Disk .....	40
● Calling Up a Registration That Was Saved (Load) .....	41
● Erasing Registrations Saved on Disk (Delete) .....	42

## **CHAPTER 6 About Floppy Disks**

---

■ Handling the Disk Drive .....	43
■ Handling Floppy Disks .....	43
■ Formatting Disks.....	44

## **CHAPTER 7 Recording/Playing Back Performances**

---

■ Recording Performances (Rec Button) .....	45
■ Erasing Performance Data (Clear).....	47
■ Playing Back Performance Data (Play Button).....	48
● Silencing a Specific Track (Track Mute).....	48
■ Saving Performance Data (Save Button) .....	49
● Changing the Name of Performance Data (Rename).....	49
● Saving Onto Disk (Save Button).....	50
■ Loading Performance Data Into the Unit (Load Button).....	51
■ Playing Back Performance Data On Disk (All Song Play Button and Play Button)....	52
■ Display/Exit Button .....	53

## **CHAPTER 8 Other Kinds of Settings**

---

■ Adjusting the Volume Balance (Part Balance Button) .....	54
■ Shifting the Pitch of Sound in Octave Units (Oct Shift Button) .....	55
■ Transpose the Pitch (Transpose Button) .....	56

■ Settings for Effects (Effect Button) .....	57
● Reverb Type .....	58
● Reverb Depth .....	58
● Sustain Length .....	58
● Rotary Speed .....	59
● Rotary Color .....	59
■ Various Other Settings (Utility Button).....	60
● Aftertouch (AT-70 Only) .....	61
● Initial Touch .....	61
● Left Foot Switch Assignment/Right Foot Switch Assignment.....	61
● Bender/Vibrato Destination .....	62
● Pitch Bend Range .....	62
● Manual Drums Set.....	62
● Solo Split Point.....	63
● Chord Hold .....	63
● Master Tune.....	63
● LCD Contrast.....	63
■ Settings for the Composer (Function Button) .....	64
● Count-In Recording .....	64
● Metronome .....	64
● Metronome Volume .....	65
● Setting for the Beat .....	65
● Erasing Performance Data .....	66
● Erasing a Track's Performance Data .....	67
● Copying Performance Data .....	68
● Quantize .....	69
● Channel Mute .....	70
Troubleshooting.....	71
Display Messages .....	73
Drum Set List.....	76
MIDI Implementation Chart .....	78
Specifications .....	79
Index .....	82
Setting Up the AT-70/50 and the ATS-70/50 Stand .....	84



In addition to the items listed under Safety Precautions inside the front cover, please read and observe the following:

## Power Supply

- Before connecting this unit to other devices, turn off the power to all units; this will help prevent damage or malfunction.
- Do not use this unit on the same power circuit with any device that will generate line noise; an electric motor or variable lighting system for example.

## Placement

- This device may interfere with radio and television reception. Do not use this device in the vicinity of such receivers.
- Make sure you always have the instrument placed so it is level and sure to remain stable. Otherwise, if played while tilted, you risk causing damage to the keyboard as a result of the unnatural degree of force that might be applied to certain parts of it.

## Maintenance

- For everyday cleaning wipe the unit with a soft, dry cloth or one that has been slightly dampened with water. To remove stubborn dirt, use a mild, non-abrasive detergent. Afterwards, be sure to wipe the unit thoroughly with a soft, dry cloth.
- Never use benzene, thinners, alcohol or solvents of any kind, to avoid the possibility of discoloration and/or deformation.

## Memory Backup

- Please be aware that the contents of memory may at times be lost; when the unit is sent for repairs or when by some chance a malfunction has occurred. Important data should be stored on a floppy disk, or written down on paper (if possible). During repairs, due care is taken to avoid the loss of data. However, in certain cases (such as when circuitry related to memory itself is out of order), we regret that it may not be possible to restore the data.

## Additional Precautions

- Protect the unit from strong impact.
- Never strike or apply strong pressure to the display.
- A small amount of heat will radiate from the unit during normal operation.
- Before using the unit in a foreign country, consult with qualified service personnel.

# PANEL DESCRIPTIONS

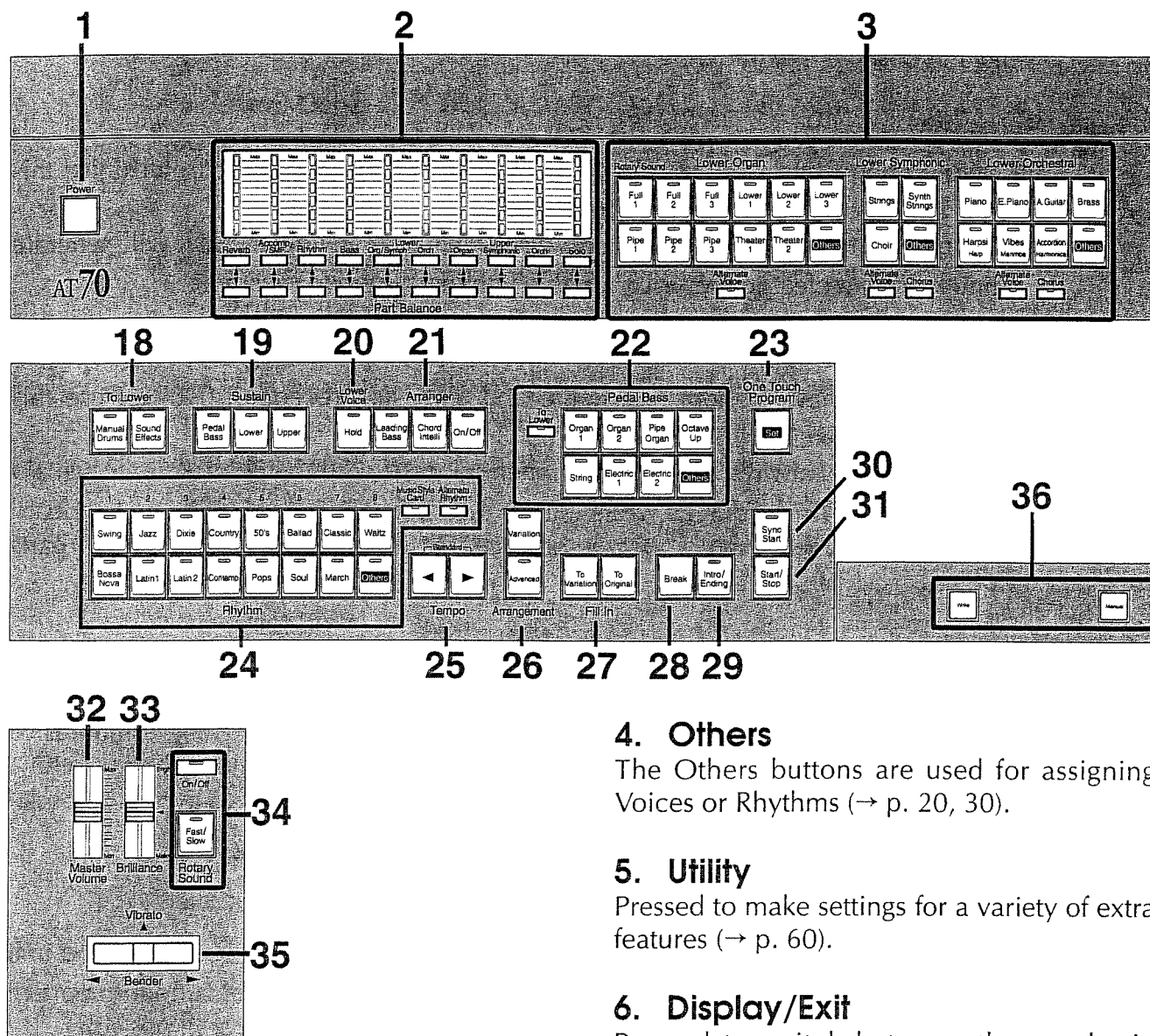

## 1. Power

Pressed to turn power on or off (→ p. 15).

## 2. Part Balance

Used to adjust the volume for each of the Parts in order to achieve the appropriate overall balance (→ p. 54).

The buttons at the far left are for adjusting the reverberation (→ p. 24).

## 3. Lower Organ, Lower Symphonic, Lower Orchestral

Used to select the Voices that you want to play using the Lower keyboard (→ p. 17). Buttons for turning on/off the chorus effect for Lower Symphonic and Lower Orchestral are also provided (→ p. 23).

## 4. Others

The Others buttons are used for assigning Voices or Rhythms (→ p. 20, 30).

## 5. Utility

Pressed to make settings for a variety of extra features (→ p. 60).

## 6. Display/Exit

Pressed to switch between the two basic screens, and to reach a basic screen from some other screen (→ p. 53).

## 7. Effect

Used to make settings for the Reverb/Sustain/Rotary effects (→ p. 57).

## 8. Menu

Pressed to switch between the Utility and Effects menus (→ p. 57, 60).

## 9. Oct Shift

Used to shift the pitch of what is played in multiples of one octave (→ p. 55).

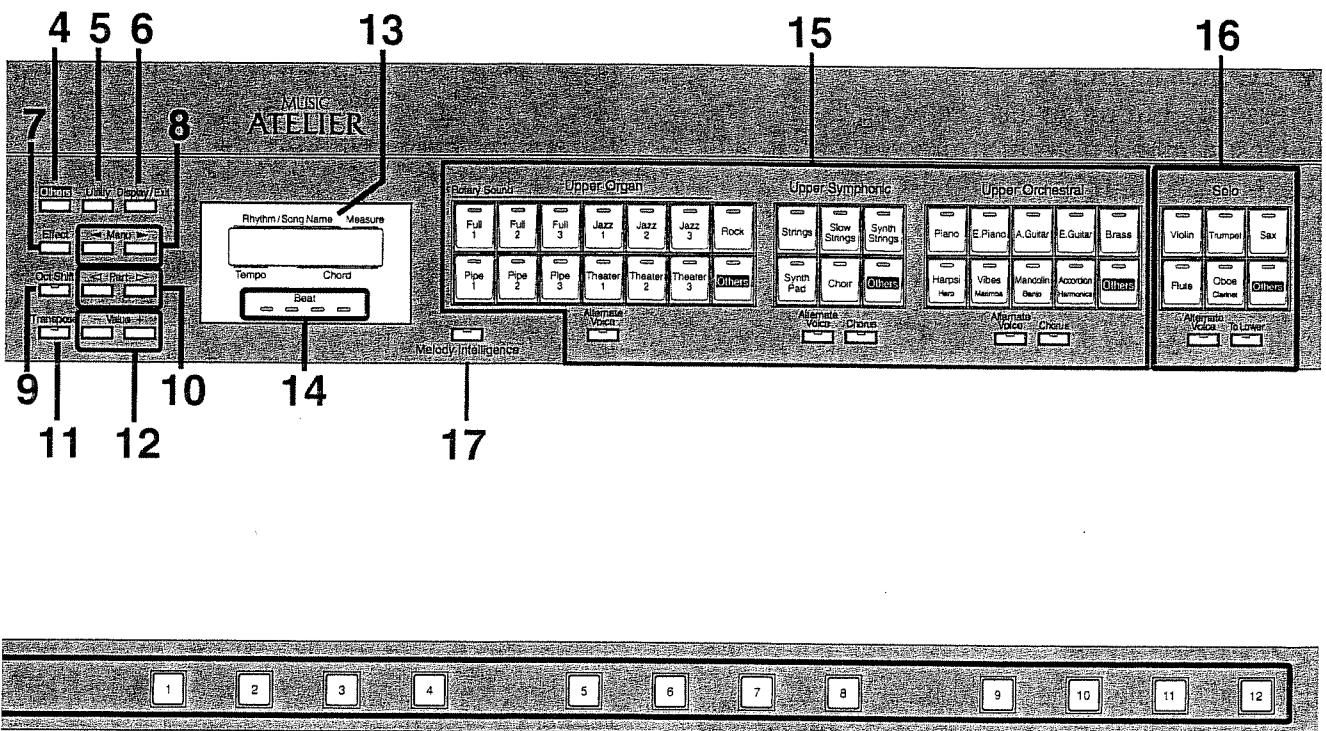

### 10. Part

Used to select the Parts when using the effects or octave shift (→ p. 55, 57).

### 11. Transpose

Used to make settings for the transpose feature (allows you to shift the soundable range of the keyboard) (→ p. 56).

### 12. Value

Used to alter the values for a variety of settings.

### 13. Display

Shows a variety of messages helpful in operating the unit.

### 14. Beat

Lights up in time with the beat (→ p. 33).

### 15. Upper Organ, Upper Symphonic, Upper Orchestral

Pressed to select the Voices to be played in the Upper keyboard (→ p. 17).

There is also a button for turning ON/OFF the chorus effect for Upper Symphonic and Upper Orchestral (→ p. 23).

### 16. Solo

Pressed to select a Solo Voice. To have the Solo Voice sounded on the Lower keyboard, press the To Lower button (→ p. 19).

### 17. Melody Intelligence

To make use of melody intelligence function (harmony will be added to the melody), press this button (→ p. 27).

### 18. To Lower

To sound manual drums on the Lower keyboard, press Manual Drums button. To play special effects, press Sound Effects button (→ p. 22).

### 19. Sustain

Used to make settings for the sustain effect. There are three: Pedal Bass, Lower, and Upper, so it can be set for each keyboard (→ p. 24).

### 20. Lower Voice

#### ● Hold

Press this button to use Lower Hold. (This feature causes notes pressed in the Lower keyboard to continue to be sounded even after you release your fingers from the keys.) (→ p. 38)

## 21. Arranger

### ● Leading Bass

Press this button to use Leading Bass. (The lowest pitched note of a pressed chord will be used as the bass sound.) (→ p. 38)

### ● Chord Intelli

Press this button to use Chord Intelligence. (Allows you to abbreviate the keys pressed when sounding chords.) (→ p. 37)

### ● On/Off

Used to select whether or not you want to add automatic accompaniment to rhythm performances (→ p. 35).

## 22. Pedal Bass

Pressed to select the Pedal Bass Voice. To sound the Pedal Bass Voice on the Lower keyboard, press the To Lower button (→ p. 18).

## 23. One Touch Program

Allows you to quickly carry out a performance consisting of a selected rhythm with automatic accompaniment (→ p. 35).

## 24. Rhythm

Pressed to select a Rhythm (→ p. 29).

## 25. Tempo

Adjusts the tempo for a performance (→ p. 33).

## 26. Arrangement

### ● Variation

Used to change the arrangement for rhythm performances and automatic accompaniment (→ p. 34).

### ● Advanced

Changes the arrangement for automatic accompaniment (→ p. 36).

## 27. Fill In

Used to insert a fill-in, thus altering the arrangement for rhythm performances and automatic accompaniment (→ p. 34).

## 28. Break

Stops the rhythm performance for one measure (→ p. 34).

## 29. Intro/Ending

Inserts an intro or ending into a rhythm performance or automatic accompaniment (→ p. 36).

## 30. Sync Start

Allows you to have a rhythm performance or automatic accompaniment start at the same moment keys are pressed on the Lower keyboard (→ p. 32).

## 31. Start/Stop

Pressed to start/stop a rhythm performance or automatic accompaniment (→ p. 32).

## 32. Master Volume

Used to adjust the overall volume (→ p. 15).

## 33. Brilliance

Adjusts the brightness of the sound (→ p. 26).

## 34. Rotary Sound

### ● Fast/Slow

Selects the speed of the rotary effect (effect simulating rotating speakers) (→ p. 25).

### ● On/Off

Switches ON/OFF the rotary effect (→ p. 25).

## 35. Bender/Vibrato

Applies the pitch bend or vibrato effects (→ p. 26).

## 36. Registration

### (Write, Manual, 1-12 (AT-50: 8)

Used to store sets of panel settings, then later call them up (→ p. 39).

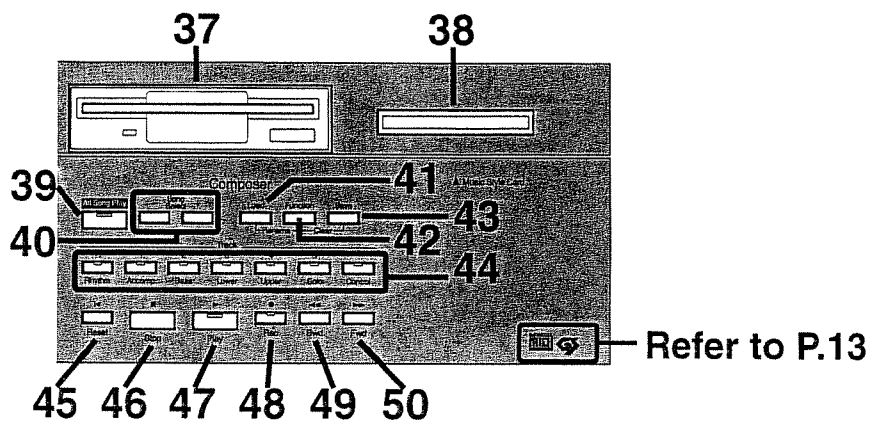

### 37. Disk Drive

Used to save performance data on disk, and to play back the performance data on disk (→ p. 43).

### 38. Music Style Card

Accepts insertion of optionally available Music Style Cards (→ p. 31).

### 39. All Song Play

Plays back all the performance data on disk, in order (→ p. 52).

### 40. Song Select

Pressed to select performance data on disk (→ p. 52).

### 41. Load

Used to load performance data on disk into the unit (→ p. 51).

### 42. Function

Used to make a variety of settings for the Composer (→ p. 64).

### 43. Save

Used to save the unit's performance data on disk (→ p. 50).

### 44. Track

Pressed to select the Track to be used for recording (→ p. 45).

### 45. Reset

Causes the unit to return to the beginning of the song, and at the same time, restore the default settings for the selected performance data (→ p. 48, 52).

### 46. Stop

Stops playback/recording of the performance data (→ p. 48, 52).

### 47. Play

Starts playback of the performance data (→ p. 48, 52).

### 48. Rec

Pressed to begin recording performance data (→ p. 45).

### 49. Bwd

Rewinds the performance data (→ p. 48).

### 50. Fwd

Fast forwards the performance data (→ p. 48).

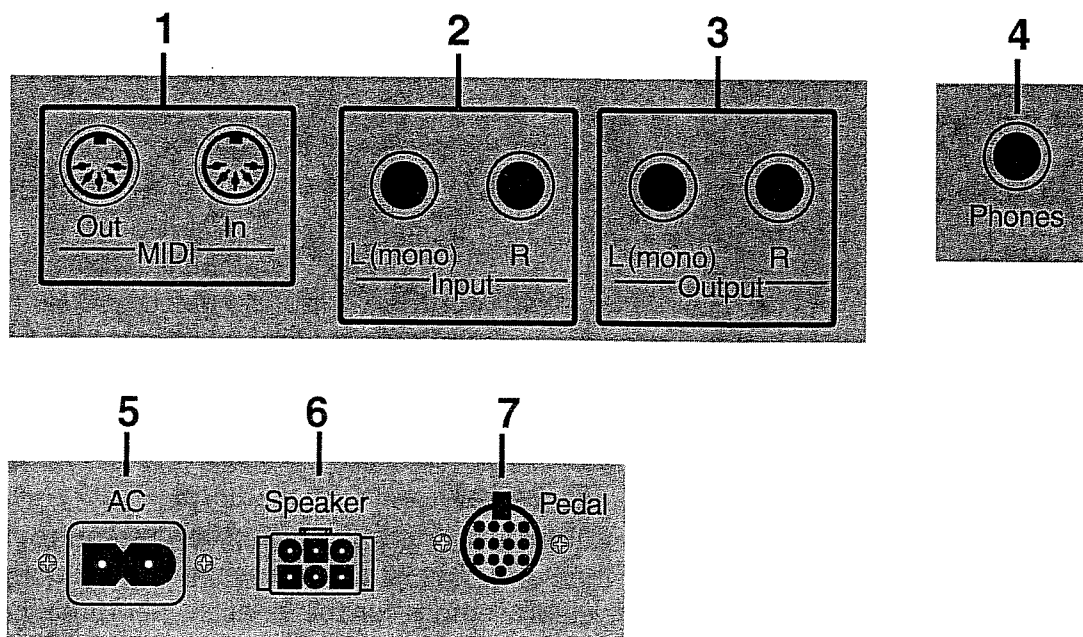

### 1. MIDI

You need to connect cables to these connectors when you wish to exchange MIDI messages with an external MIDI device.

### 2. Input L (Mono)/ R

Connect a tape recorder or CD player here, and their sound will also be heard from the internal speakers along with what you play on the AT-70/50. This conveniently allows you to practice along with your favorite music.

### 3. Output L (Mono)/ R

Connect here when you want your music to be sounded by a keyboard amplifier or other audio equipment.

Also, when you wish to record what you play on the AT-70/50 onto a tape recorder, connect a cable from here to the input jack on your tape recorder.

### 4. Phones

Accepts connection of headphones (RH-20/80/120: optionally available). Because sound will no longer be output from the AT-70/50's speakers when you connect headphones, you can practice even late at night without disturbing others.

*\* The volume level as heard through headphones can be adjusted with either the Master Volume slider or the expression pedal. Be careful, though, since excessive volume levels can cause damage to your hearing.*

### 5. AC Inlet

Here is where you connect the supplied power cord.

### 6. Speaker

Here is where you connect the speakers that come with the special stand.

### 7. Pedal

Here is where you connect the pedal keyboard/expression pedal/damper pedal that come with the special stand.



## General MIDI System

The General MIDI System is a set of recommendations which seek to provide a way for going beyond the limitations of proprietary designs, and standardize the MIDI capabilities provided by sound generating devices.

If you use a sound generating unit which carries the General MIDI logo, you will be able to faithfully reproduce any song data which also carries the General MIDI logo.



## GS Format

The GS Format is Roland's universal set of specifications which were formulated in the interest of standardizing the way in which sound generating devices will operate when MIDI is used for the performance of music. If you use a sound generating unit which carries the GS logo, you will be able to faithfully reproduce any commercially available song data which also carries the GS logo.

This product supports both General MIDI and GS.  
Song data which carries either of these logos can be accurately reproduced.

## ***SMF***

This device can playback Standard MIDI Files (720 Kbyte format, 3.5 inch floppy disk) such as SMF Music Data.

## Connecting the Power Cord

1. First, make sure that the Power switch at the panel's left side is OFF (not pushed in).
2. Connect the supplied power cord to the AC Inlet connector (under the unit), then plug the other end into an AC outlet.

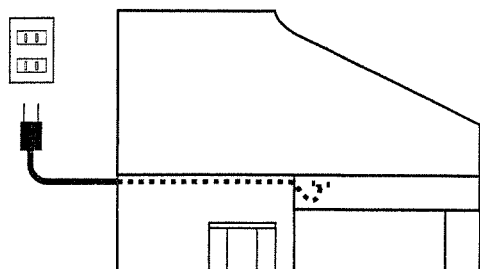

- \* Always use only the power cord supplied with this instrument.
- \* Whenever you do not intend to use the instrument for extended periods of time, pull out the power cord from the AC outlet.

## Setting up the Music Stand

Raise the music stand, and bend the metal joints as shown in the illustration below.

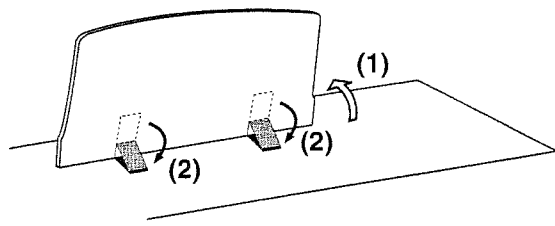

## Opening the Cover

To open the cover, hold it with both hands and lift it straight up. Then, slide it to the rear.

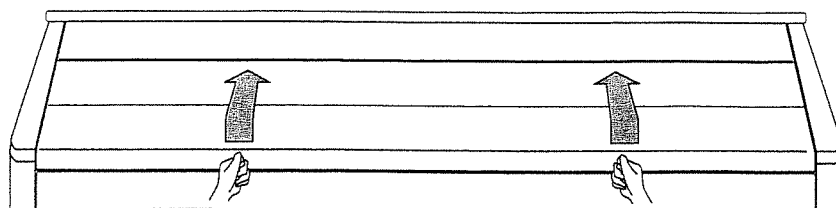

- \* Be careful not to get your fingers caught when opening or closing the cover. To close the cover, slowly pull it forward until it stops. Then, gently lower it into place. Adult supervision is recommended when small children are going to be using the instrument.
- \* Make sure you don't have anything (such as sheet music) on the keyboard when you close the cover.



## ■ Turning On Power

First, check that the power cord is connected, that the Master Volume slider is turned down, and that the expression pedal is at the fully released position.

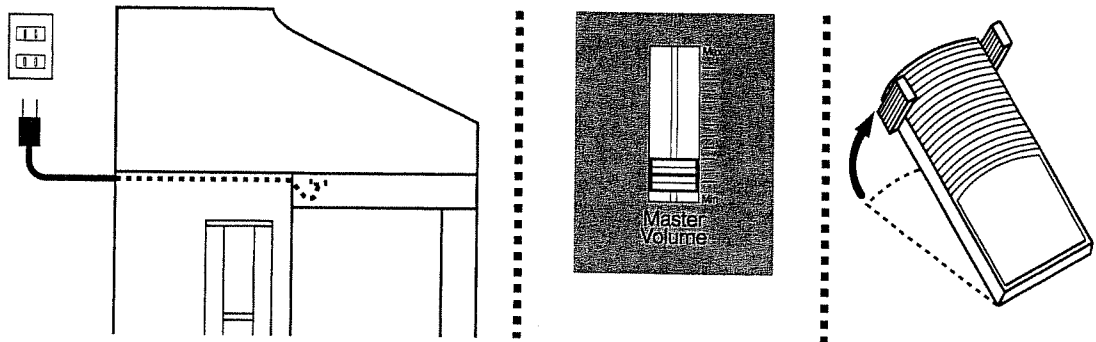

**Press the Power switch to turn ON power.**

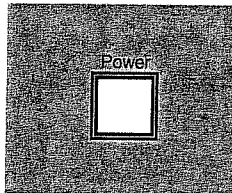

## ■ Adjusting the Volume

Using the Master Volume slider, adjust the volume to an appropriate level.

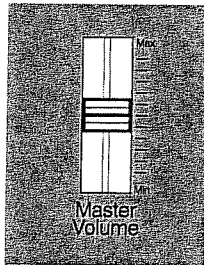

Also, an expression pedal can be used to adjust the overall volume; depress it to increase the volume and release it to decrease the volume.

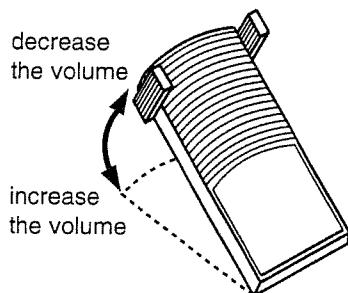

## ■ Restoring All the Factory Default Settings

Perform the procedure below to return the AT-70/50 to all the settings it had when it was new.

*\* Make sure there is no floppy disk in the disk drive before carrying out the procedure.*

**Turn on power while holding down the One Touch Program button.**

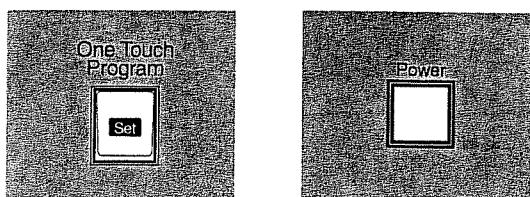

Factory Setup  
is Loaded.

*\* When you are using the instrument for the very first time, or it has remained unused for about a month or so, it will automatically be placed at the factory default settings when you turn the power on.*

# CHAPTER 2 How To Select Voices

## ■ Upper and Lower

There are three Parts each (Organ, Symphonic, and Orchestral) for both the Upper and Lower keyboards. You can select one Voice for each Part, so up to a maximum of three Voices can be sounded while layered together.

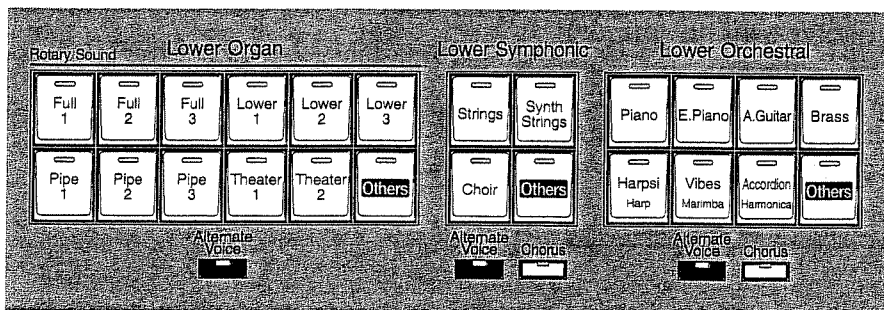
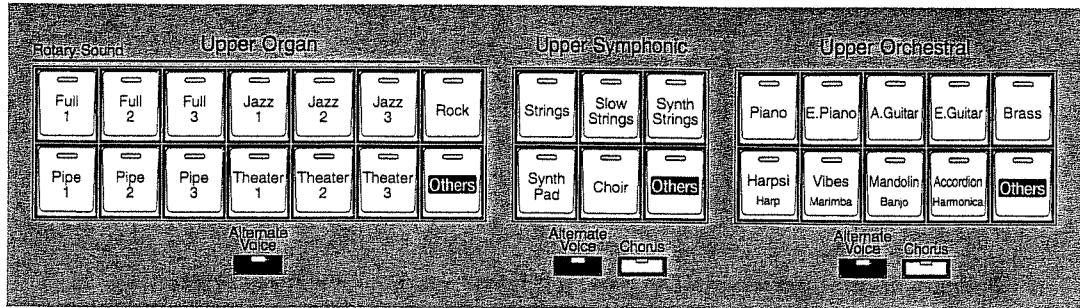

**1. Press a Voice button and confirm that its indicator is lit.**

With each press of the button, it is either lighted or turned off. A Voice which has its button lighted will be sounded.

When all the indicators are out (OFF), no Voice will sound for that Part.

Two Voices in the same general category are assigned to each Voice button. (Except for the buttons which have two Voice names printed on them. In this case they are from different categories.)

Use the Alternate Voice button to select between the two Voices.

**2. Press the desired Alternate Voice button to turn the indicator on or off.**

With each press of the button, it is either lighted or turned off, which indicates that one or the other of the Voices is selected.

The name of the selected Voice is shown in the display for several seconds.

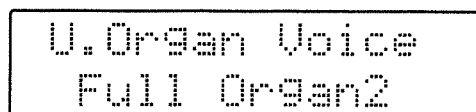

## ■ Pedal Bass Part

Select the Bass Voice to be sounded with the pedal keyboard. Only one Voice is used for sounding the Bass Voice.

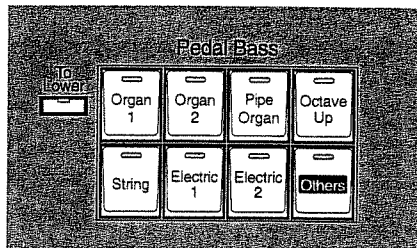

**Press the desired Voice button and confirm that its indicator is lit.**

With each press of the button, it is either lighted or turned off. The Voice which has its button lighted will be sounded.

When all the indicators are out (OFF), no Bass Voice will sound.

The name of the selected Voice is shown in the display for several seconds.

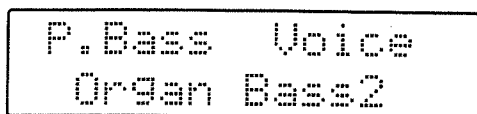

- ◆ By pressing the Octave Up button (its indicator lights), what you play will sound one octave higher in pitch
- ◆ By pressing the To Lower button (its indicator lights), the Bass Voice will sound using the root of the chord played on the Lower keyboard. If all three Parts for Lower are OFF, the Bass Voice can be played on the Lower keyboard.

## ■ Solo Part

Follow the steps below to select the Voice to be used for solo performances (Solo Voice). The Solo Voice will ordinarily be sounded for the highest notes played on the Upper keyboard.

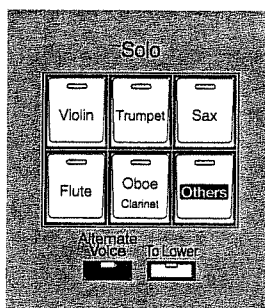

### 1. Press a Voice button and confirm that its indicator is lit.

With each press of the button, it is either lighted or turned off. Every Voice that has its button lighted will be sounded.

No Solo Voice will sound when all the indicators are out (OFF).

For most buttons, two Voices of the same general type are assigned to each. (Where the Voices are from different categories, two Voice names appear on the button.)

Use the Alternate Voice button to select between the two Voices.

### 2. Press the Alternate Voice button. The button indicator will light (or go dark) to indicate which of the two Voices is selected.

The name of the selected Voice is shown in the display for several seconds.

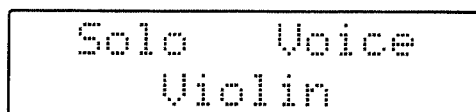

- ◆ When you press the To Lower button (and confirm that its indicator is lit), the Solo Voice will sound when the notes to the right of the B4 key on the Lower keyboard are played. This key is known as the “Solo Split Point.”

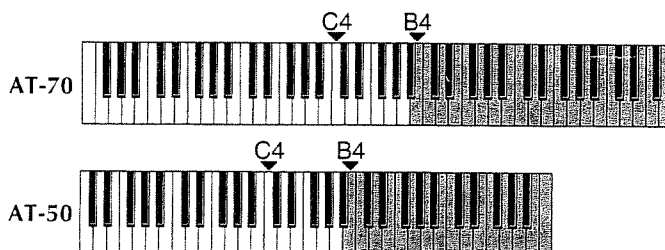

---

You can alter the Solo Split Point any time you wish. (→ p. 63)

---

## ■ How to Use the Others Buttons

There are eight Others buttons, one for each Part. You can assign two Voices (and one for pedal bass) to these buttons.

\* *You cannot assign a pair of the same Voice to them.*

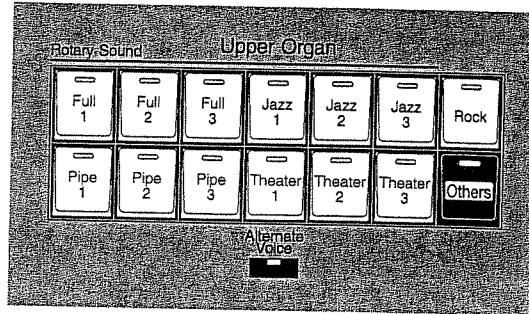
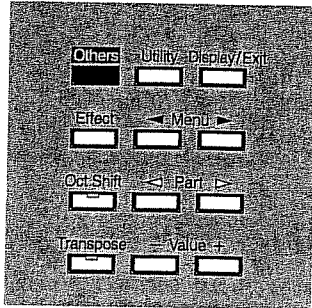

1. Press the Others button to the left of the display.
2. Press the Others button for the Part to which you wish to assign a Voice.
3. Press the Alternate Voice button as necessary.  
This step is unnecessary in the case of Pedal Bass.
4. Use the Value buttons to select the desired Voice.

The name of the selected Voice is shown in the display.

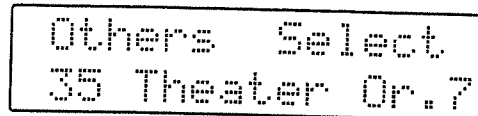

5. Once again, press the Others button to the left of the display, or an Others button for a Part to be assigned a Voice.

Voices which can be assigned to an Others button are as follows. However, you cannot assign Voices that are already assigned to each Part.

1 Full Organ1	44 Slow Str.2	87 Hawaiian Gt.
2 Full Organ4	45 Synth. Str.1	88 Organ Harp
3 Full Organ2	46 Synth. Str.2	89 Fr.Horn Sect
4 Full Organ5	47 Synth. Pad1	90 Synth. Brass
5 Full Organ3	48 Synth. Pad2	91 Sitar
6 Full Organ6	49 Choir	92 Steel Drums
7 Jazz Organ1	50 Pop Voice	93 Violin
8 Jazz Organ4	51 Synth. Choir	94 Cello
9 Jazz Organ2	52 Synth. Voice	95 Trumpet
10 Jazz Organ5	53 Space Voice	96 Mute Trumpet
11 Jazz Organ3	54 Synth. Str.3	97 Alto Sax
12 Jazz Organ6	55 Synth. Flute	98 Tenor Sax
13 Rock Organ1	56 Pizzicato	99 Flute
14 Rock Organ2	57 Piano1	100 Pan Flute
15 Lower Organ1	58 Honky-tonk	101 Oboe
16 Lower Organ4	59 E.Piano1	102 Clarinet
17 Lower Organ2	60 E.Piano2	103 Viola
18 Lower Organ5	61 Nylon-str.Gt	104 Flugel Horn
19 Lower Organ3	62 Steel-str.Gt	105 Trombone
20 Lower Organ6	63 Jazz Guitar	106 Soprano Sax
21 Pipe Organ1	64 Overdrive Gt	107 Bassoon
22 Pipe Organ4	65 Tp. Section	108 Shakuhachi
23 Pipe Organ2	66 Sax. Section	109 HumanWhistle
24 Pipe Organ5	67 Harpsichord	110 Synth. Lead1
25 Pipe Organ3	68 Harp	111 Synth. Lead2
26 Pipe Organ6	69 Vibraphone	112 Synth. Lead3
27 Theater Or.1	70 Marimba	113 Synth. Lead4
28 Theater Or.4	71 Mandolin	114 Synth. Lead5
29 Theater Or.2	72 Banjo	115 Organ Bass1
30 Theater Or.5	73 Accordion	116 Organ Bass2
31 Theater Or.3	74 Harmonica	117 Pipe Org. Bs
32 Theater Or.6	75 Org. Attack1	118 String Bass
33 Full Organ7	76 Org. Attack2	119 E.Bass1
34 Pipe Organ7	77 Org. Attack3	120 E.Bass2
35 Theater Or.7	78 Org. Attack4	121 Contrabass1
36 Synth Org.1	79 Org. Click	122 Contrabass2
37 Synth Org.2	80 Piano2	123 Tuba
38 Pop Organ1	81 Clavi.	124 Synth. Bass1
39 Pop Organ2	82 Celesta	125 Synth. Bass2
40 Pop Organ3	83 Glockenspiel	126 Bass+Cymbal
41 Strings1	84 Xylophone	127 Perc. Set1
42 Strings2	85 Tubular-bell	128 Perc. Set2
43 Slow Str.1	86 Bandoneon	

---

## ■ Drums and Sound Effects

The Lower keyboard can be used to play a variety of Drum sounds (Drum Sets) and sound effects.

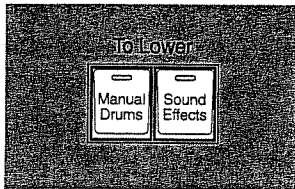

**Press the Manual Drums button or the Sound Effects button (the corresponding indicator will light when the selected function is active).**

- \* *You cannot select both a Drum sound and a sound effect at the same time.*
- \* *For a complete listing of all the different drum and sound effects that will be produced for each individual key, refer to the "Drum Set List" (p. 76).*

---

**You can make changes in a Drum Set. (→ p. 62)**

---



## ■ Chorus Effect

Chorus is an effect that adds expansiveness to a sound, making one instrument sound like several. The Chorus effect can be used on four Parts: Upper Symphonic, Upper Orchestral, Lower Symphonic, and Lower Orchestral. (There is a Chorus button for each Part.) Additionally, you can set chorus to be ON/OFF for each Voice.

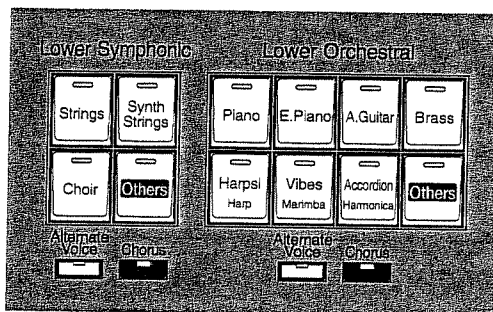
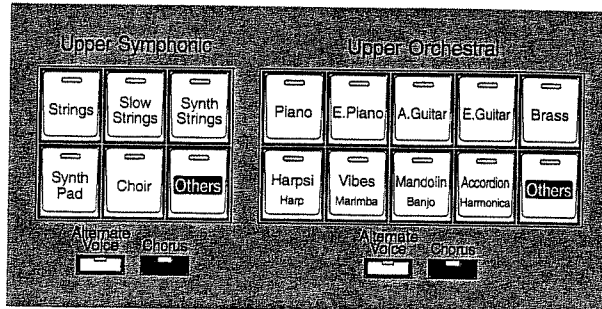

1. Select the Voice you wish to add chorus to.
2. Press the Chorus button that corresponds to the Part of the selected Voice. (Confirm that the indicator lights.)

\* Voices No. 1-12, 15-20, 33 and 38-40 (→ p. 21) cannot have chorus applied to them.

\* These settings remain stored in memory even while the power is off.

## ■ Reverb Effect

Reverb is an effect that adds a sense of spaciousness to sound, creating the sonic illusion of playing in a large concert hall.

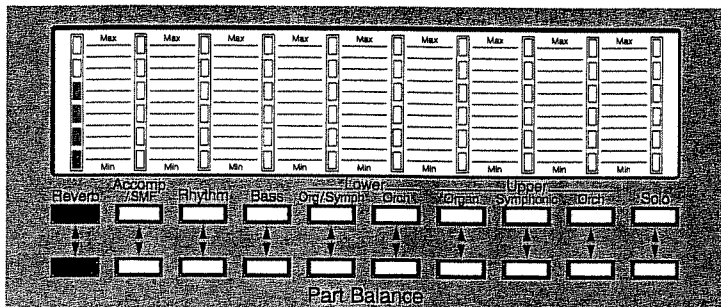

**Press the Reverb button to adjust the reverb level.**

When you press the upper button (▲), more reverb is applied. Pressing the lower button (▼) decreases the reverb level.

When all the indicators are out, no reverb at all will be applied.

---

**You can also select the type of reverb you want and the level (amount) for each Part. (→ p. 58)**

---

## ■ Sustain Effect

Sustain allows you to have Voices sustained (held). The sustain effect can be obtained for the Upper (except the Solo Voice), Lower, and Pedal Bass Voices.

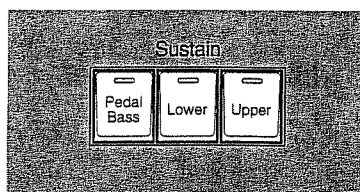

**Press the Sustain button for the section to which you want sustain applied. (Confirm that the indicator lights.)**

---

**The duration of the sustain can be set for each Section. (→ p. 58)**

---

## ■ Rotary Effect

Rotary is an effect which simulates the sound you get when speakers are rotated. There are two settings; Fast and Slow.

Rotary is effective for the Voices assigned to the upper row of buttons for Upper Organ and Lower Organ (except Rock Organ). In other words, the Voices numbered 1-12 and 15-20 (→ p. 21). The effect can also be used when these Voices plus those numbered 33 and 38-40 are assigned to an Others button (except the Others buttons for Solo and Pedal Bass).

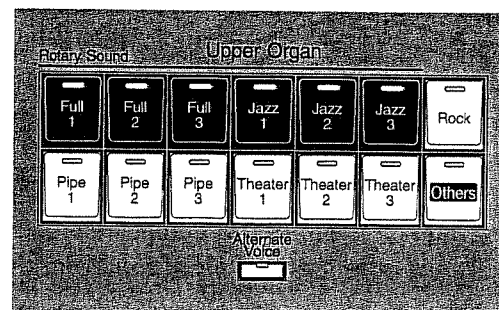
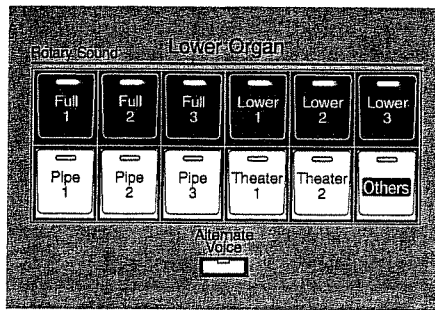

1. Select the Voice to which you want to apply the rotary effect.
2. Press the Rotary Sound On/Off button (and confirm that its indicator lights).
3. Press the Rotary Sound Fast/Slow button.

Lit → Fast : The effect obtained is equivalent to speakers being rapidly rotated.

Dark → Slow : Effect simulating the slow rotation of speakers.

---

You can also finely adjust the speed of the speaker's rotation, and alter the brightness of the sound obtained when rotary is applied. (→ p. 59)

---

## ■ Pitch Bend and Vibrato Effects

When you move the pitch bend/vibrato lever to the left or right, you can obtain a smooth transition in the pitch of notes played (pitch bend effect). Push the lever to the right to raise the pitch, and to the left to lower it.

Also, when you push the lever to the top, a vibrato effect can be obtained.

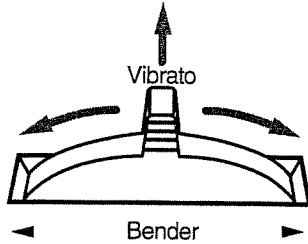

- \* *As a default setting (immediately after the power is turned on) the effect is obtained for what is played on the Upper keyboard.*
- \* *Please note that not all of the Voices will allow vibrato to be applied.*

---

You can change the settings so the effect is also applied to the Lower or pedal keyboards, if you wish.

Also, you can specify a different value for the maximum amount of change in the pitch that can be obtained. (→ p. 62)

---

## ■ Using the Brilliance Slider to Adjust Timbre

The Brilliance slider allows you to alter the overall tonal color.

When you push the slider up, the sound becomes brighter, and push the slider down, the sound becomes mellower.

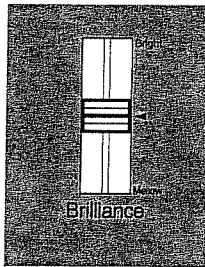

## ■ Adding Harmony to Melodies (Melody Intelligence Button)

Melody Intelligence is a function that adds harmony to the melodies you play on the Upper keyboard. The harmony created depends directly on the chords played on the Lower keyboard.

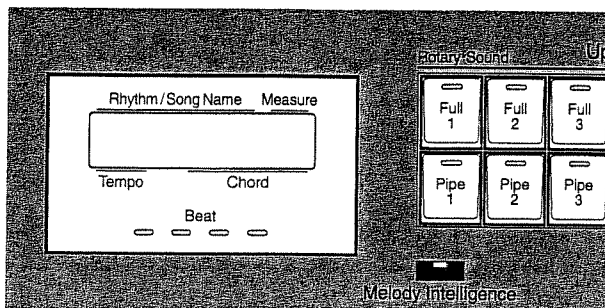

Press the Melody Intelligence button (and confirm that the indicator lights).

## ■ Adjusting Overall Volume Using the Expression Pedal

When you depress the expression pedal, the volume increases. It is lowered as you release the pedal.

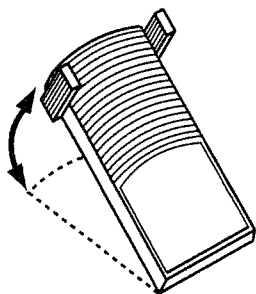

\* *The pedal will not work for the playback of performance data from a source other than the AT-70/50.*

## ■ Foot Switches

The instrument provides two foot switches, one on each side of the expression pedal.

When you move the left switch towards the left, you obtain a glide (pitch is momentarily lowered, then returned to what it was originally). You can switch between Fast/Slow for the Rotary effect by moving the switch on the right to the right.

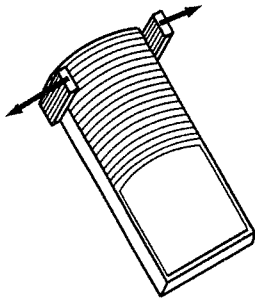

*\* The Glide effect will be obtained from only the keyboard section which has been specified as being the destination for the Pitch Bend/Vibrato lever (→ p. 62).*

---

**You can also change the functions assigned to the left and right switches.**  
(→ p. 61)

---

## ■ Damper Pedal

When you depress the pedal, the damper effect is applied to the Voice played on the Lower keyboard.

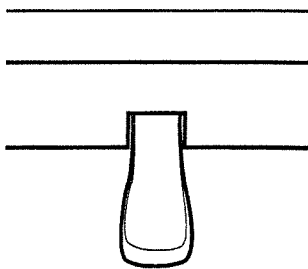

*\* When the indicator on the To Lower button is lit, the damper effect will not be applied to the Solo Voice or Bass Voice produced by the Lower keyboard.*

The AT-70/50 provides 64 different internal Rhythms. They allow you to play while accompanied by a Rhythm performance.

## ■ How to Select a Rhythm

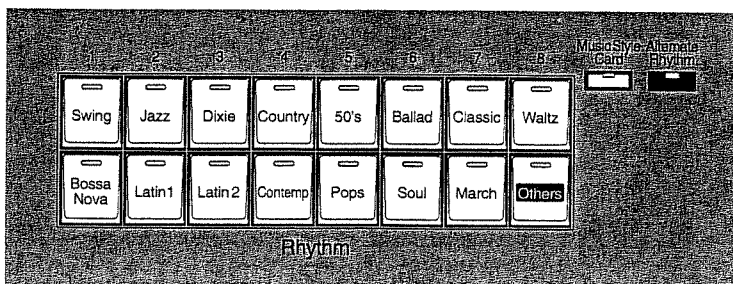

### 1. Press the Rhythm button (confirm that the indicator lights).

Two types of Rhythms are assigned to each button. Switch between the two using the Alternate Rhythm button.

### 2. Use the Alternate Rhythm button to switch between the two available Rhythms.

With each press of the button, the indicator is on or off, indicating the two different selections.

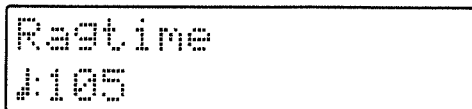

<b>Swing</b> Swing Big Band	<b>Ballad</b> Slow Rock Country Ballad	<b>Latin 2</b> Chacha Mambo
<b>Jazz</b> Ragtime Fox trot	<b>Classic</b> Classical Broadway	<b>Contemp</b> Contemporary Dance
<b>Dixie</b> Dixie Charleston	<b>Waltz</b> Slow Waltz Country Waltz	<b>Pops</b> Pop Piano Ballad Shuffle
<b>Country</b> Two-step Bluegrass	<b>Bossa Nova</b> Bossa Nova Samba	<b>Soul</b> Gospel R&B
<b>50's</b> Twist Boogie	<b>Latin 1</b> Rhumba Tango	<b>March</b> March4/4 March6/8

## ● How to Use the Others Button

You can assign two Rhythms to an Others button in the same way as for Voices.

*\* You cannot assign a pair of same Rhythm to it.*

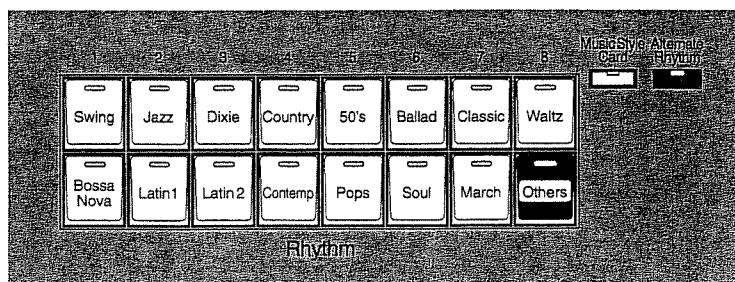
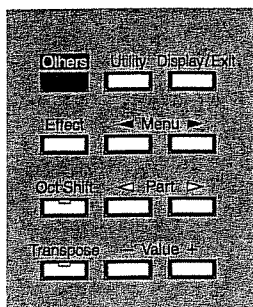

1. Press the Others button to the left of the display.
2. Press the Others button in the Rhythm Section.
3. Press the Alternate Rhythm button to turn the indicator on or off.
4. Use the Value buttons to select a Rhythm to be assigned.

The name of the selected Rhythm is shown in the display.

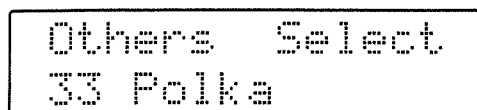

5. Once again press the Others button to the left of the display, or the Others button in the Rhythm section.

The following 34 Rhythms can be assigned to an Others button.

1 Baroque 1	13 Slow Swing	25 Rock 1
2 Baroque 2	14 Afro/Swing	26 Rock 2
3 Vienna Waltz	15 8Beat 1	27 Reggae
4 Rock'N'Roll 1	16 8Beat 2	28 African
5 Rock'N'Roll 2	17 16Beat 1	29 Bossa Nova 2
6 Blues	18 16Beat 2	30 Salsa
7 PopRock	19 Funk	31 Beguine
8 Shuffle	20 Disco 1	32 Folk Waltz
9 Country Swing	21 Disco 2	33 Polka
10 Train-Beat	22 Pop 1	34 Hawaiian
11 Big Band 2	23 Pop 2	
12 Jazz Waltz	24 Pop 3	



## ■ Using a Music Style Card

You can choose from another eight Rhythms when you use an optionally available Music Style Card (TN-SC2 series).

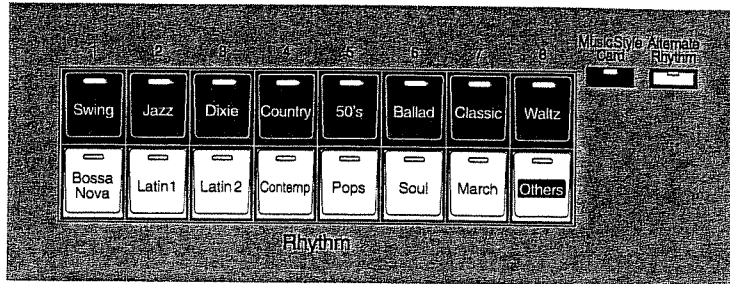

### 1. Insert a Music Style Card into the card slot.

Make sure you have the proper side facing up, and the appropriate end pointed forward; gently but firmly insert the card all the way into the slot.

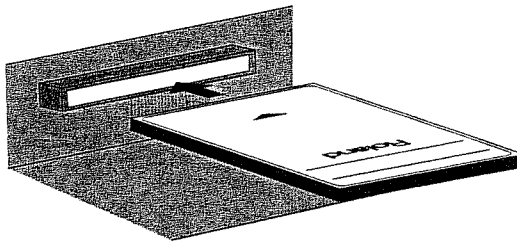

### 2. Press the Music Style Card button (confirm that the indicator lights).

The indicators on the Rhythm buttons in the upper row will flash.

### 3. Press one of the flashing buttons (1-8) to select a Rhythm.

To return to selecting internal Rhythms, press the Music Style Card button again (so the indicator goes out).

---

## ■ Starting/Stopping Rhythms

Once you have the desired Rhythm selected, try playing it while you play along.

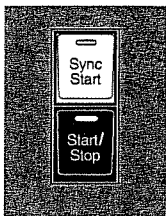

**Press the Start/Stop button to start and stop the Rhythm.**

## ● Using the Sync Start Function

The Sync Start Function causes a Rhythm to start playing the instant you play anything on the Lower keyboard.

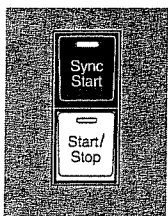

**Press the Sync Start button (confirm that its indicator lights).**

## ■ Altering the Tempo of a Rhythm

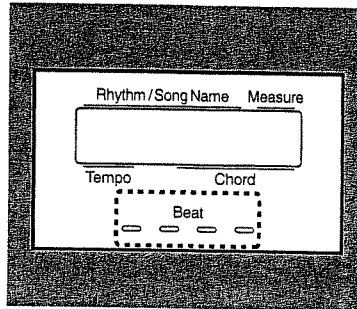
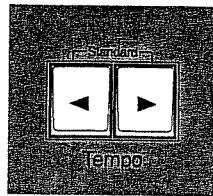

**Press the Tempo button to adjust the tempo of the Rhythm.**

The tempo becomes faster when you press the ► Tempo button, and becomes slower when you press ◀.

The current Tempo value (30-250 beats per minute) can be checked in the display.



You can also check the tempo by viewing the beat indicator. The indicator flashes red on the first beat, and green on the remaining beats.

*\* By pressing the ◀ and ► Tempo buttons simultaneously, you are returned to the standard (preset) tempo for the selected Rhythm.*

---

## ■ Applying Change to a Rhythm

### ● Changing a Rhythm's Arrangement (Variation Button)

The Variation button can be used to switch to a different arrangement of the selected Rhythm.

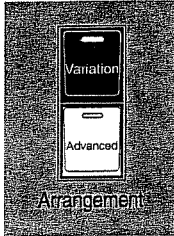

**Press the Variation button.**

**Lit → Variation** : A somewhat more complex Rhythm Pattern  
**Dark → Original** : A basic Rhythm Pattern

### ● Inserting a Fill-In (To Original Button/To Variation Button)

A Fill-In is a phrase which is inserted at certain transition points in a melody, or at places where the feeling of the song changes.

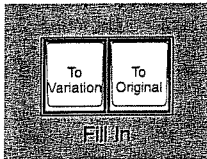

**Press the To Original button or To Variation button while a Rhythm is playing.**

**To Original** : The arrangement reverts to the Original form after the Fill-In is complete.  
**To Variation** : The arrangement changes to the Variation form after the Fill-In is complete.

### ● Inserting Empty Measures (Break Button)

This feature is used to interrupt the Rhythm performance for a single measure.

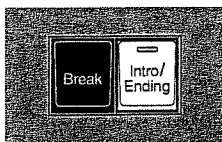

**Press the Break button while a Rhythm is playing.**

## ■ Adding Automatic Accompaniment to Rhythm Performances

Using the Arranger feature, you can add automatic accompaniment to Rhythm performances. The Arranger creates an automatic accompaniment that is ideal for the selected Rhythm. The Automatic accompaniment will reflect the chords played on the Lower keyboard.

### ● Easy Preparation For Automatic Accompaniment (One Touch Program Button)

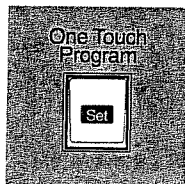

**Press the One Touch Program button.**

The instrument will be made ready for play of an automatic accompaniment that is ideal for the selected Rhythm.

When you then play a chord on the Lower keyboard, a Rhythm + automatic accompaniment begins.

*\* When the Pedal Bass Voice is OFF, the Bass Voice is used for the automatic accompaniment.*

### ● Switching Automatic Accompaniment On/Off (Arranger On/Off Button)

This setting allows you to choose (by switching the Arranger On/Off) whether or not you want to add automatic accompaniment to a Rhythm performance.

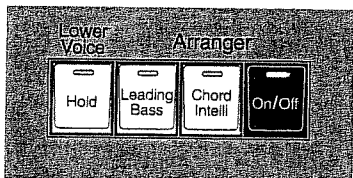

**Press the Arranger On/Off button.**

Lit → ON : Rhythm performance + automatic accompaniment  
Dark → OFF : Rhythm performance only

## ● Inserting an Intro (Intro/Ending Button)

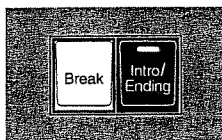

### Press the Intro/Ending button.

When Sync Start is turned ON, the button will begin flashing (indicating it is in standby). When you then play something on the Lower keyboard, an Intro will be played and then a Rhythm + automatic accompaniment will start.

When Sync Start is OFF, the Intro is played right away, then a Rhythm + automatic accompaniment will start.

- \* *If the Arranger On/Off button is OFF, only the Rhythm will start playing.*
- \* *While an intro is playing as part of a rhythm performance to which automatic accompaniment has been added, nothing will be heard if you try playing the Lower keyboard.*

## ● Inserting an Ending (Intro/Ending Button)

### Press the Intro/Ending button while a Rhythm + automatic accompaniment (or only a Rhythm) is playing.

An Ending phrase will be inserted after the current measure is complete and play will then stop automatically.

- \* *While an ending is playing as part of a rhythm performance to which automatic accompaniment has been added, nothing will be heard if you try playing the Lower keyboard.*

## ● Changing the Automatic Accompaniment Arrangement (Advanced Button)

The automatic accompaniment arrangement can be changed using not only the Variation button, but also the Advanced button.



### Press the Advanced button.

- |                |   |
|----------------|---|
| Lit → Advanced | : A fairly complex arrangement using many instruments |
| Dark → Basic   | : A simple arrangement using fewer instruments        |

- \* *The arrangement for the Rhythm itself cannot be changed using the Advanced button.*

## ● Using Easy Fingering to Play Chords (Chord Intelli Button)

On the Lower keyboard, you can play six representative chords using simpler fingering.

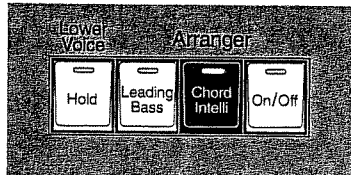

**Press the Chord Intelli button (confirm that its indicator lights).**

The types of chords that can be used with the Chord Intelligence function, and the fingering that should be used, are as follows.

**Chord Intelligence : ON**

Maj	Maj 7	7th	Min	Min 7	dim
C	B/C	B $\flat$ /C	C/E $\flat$	B $\flat$ /C/E $\flat$	C/F#
C#	C/C#	B/C#	C#/E	B/C#/E	C#/G
D	C#/D	C/D	D/F	C/D/F	D/A $\flat$
E $\flat$	D/E $\flat$	C#/E $\flat$	E $\flat$ /F#	C#/E $\flat$ /F#	E $\flat$ /A
E	E $\flat$ /E	D/E	E/G	D/E/G	E/B $\flat$
F	E/F	E $\flat$ /F	F/A $\flat$	E $\flat$ /F/A $\flat$	F/B
F#	F/F#	E/F#	F#/A	E/F#/A	F#/C
G	F#/G	F/G	G/B $\flat$	F/G/B $\flat$	G/C#
A $\flat$	G/A $\flat$	F#/A $\flat$	A $\flat$ /B	F#/A $\flat$ /B	A $\flat$ /D
A	A $\flat$ /A	G/A	A/C	G/A/C	A/E $\flat$
B $\flat$	A/B $\flat$	A $\flat$ /B $\flat$	B $\flat$ /C#	A $\flat$ /B $\flat$ /C#	B $\flat$ /E
B	B $\flat$ /B	A/B	B/D	A/B/D	B/F

## ● Leading Bass Function (Leading Bass Button)

When automatic accompaniment is used, and when the To Lower switch for the Pedal Bass Part is ON, the lowest note of the chord played is used as the bass sound. If you play an inverted chord, the bass sound will, of course, be different.

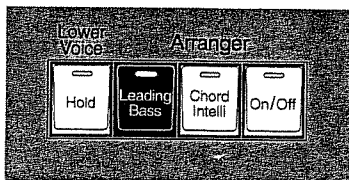

Press the **Leading Bass** button (confirm that the indicator lights).

## ● Sustaining Notes Played on the Lower Keyboard (Lower Voice Hold Button)

When Lower Voice Hold is ON, the note(s) played on the Lower keyboard will continue to sound until you play the next note(s) — even if you release the keys you have played.

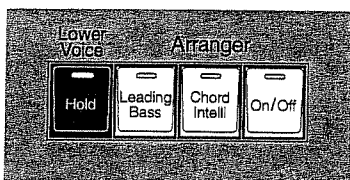

Press the **Lower Voice Hold** button (confirm that the indicator lights).

© 2013 Yamaha Corporation. All rights reserved. Yamaha and the Yamaha logo are registered trademarks of Yamaha Corporation. The name of the product is a registered trademark of Yamaha Corporation. The name of the product is a registered trademark of Yamaha Corporation.



The instrument allows you to store all the panel settings and then recall them instantly for future use. Each stored panel setting is called a “Registration.” (The AT-70 allows you to store twelve such Registrations, while the AT-50 can store eight.)

## ■ Storing Registrations

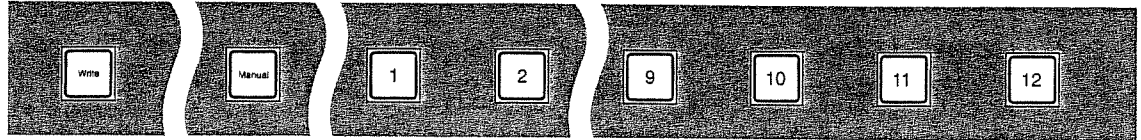

1. Make all the panel settings that you want to have stored.
2. While holding down the Write button, press a button from 1 to 12 (or 1 to 8 in the case of the AT-50).

*\* Stored settings will be retained in memory even after the main power is turned off.*

## ■ How To Call Up Settings

### To Call Up Settings For Everything Other Than Rhythm Performances:

**Press a button from 1 to 12 (or 1 to 8 on the AT-50).**

The indicator lights, and the settings for everything (other than a Rhythm performance) are instantly recalled.

### To Call Up Settings That Include Data About Rhythm Performances:

**Continue holding (for several seconds) a button from 1 to 12 (or 1 to 8) until the buttons related to Rhythm performance flash.**

The indicator lights, and the settings that include data about a Rhythm performance are recalled.

## ■ How to Use the Manual Button

When the Manual button is ON (lit), all panel settings you make will be stored automatically as they are made, thus updating the Registration that had been previously saved.

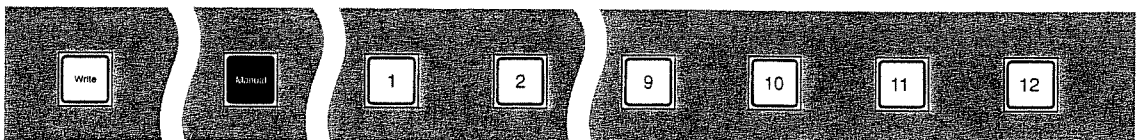

## ■ Saving Registrations on Floppy Disk

Sets of Registrations can be saved on floppy disk. The complete group of settings stored for buttons 1-12 (8) are considered as one set. Up to 99 of such sets can be stored on a disk.

*\* Every brand new floppy disk, as well as any which have been used previously with some other device, must first be formatted (prepared) for use with the AT-70/50. To do this, follow the procedure on p. 44.*

1. Have a floppy disk formatted for the AT-70/50 inserted in the disk drive.
2. Press the Function button.
3. Using the Song Select button, select "Save Regist." Then press the Rec button.

```
■ Save Regist ■  
Yes:REC
```

4. Using the Bwd/Fwd buttons, select the number that you want to save.

For numbers which have not been saved, "---" will be shown, as follows.

```
REGIST-01    ---  
Save:REC </>/RST
```

5. To perform the save, press the Rec button.  
To cancel the procedure, press the Reset button.

Once saved on the floppy disk, the "---" that appeared in the display will change to "USE."

```
REGIST-01    USE  
Save:REC </>/RST
```

*\* Caution! If you perform a save with respect to a number where "USE" appears, the former Registration will be erased, and the newly saved Registration will be written in its place.*

You can make changes in the Registration name when saving to disk.

1. With the name shown in the display, simultaneously press the Load and Function buttons.
2. Get the character that you want to change to flash using the Rec and Reset buttons. Then use the Bwd/Fwd buttons to change the character.

The characters which are available are as follows:-----

0 1 2 3 4 5 6 7 8 9 space ! " # % & ' ( ) \* + , - . / : ; = ? ^ \_  
A B C D E F G H I J K L M N O P Q R S T U V W X Y Z  
a b c d e f g h i j k l m n o p q r s t u v w x y z

The Load button can also be used to delete a character, and the Save button can be used to insert a space.

3. When finished editing the name, simultaneously press the Load and Function buttons again.

\* You cannot directly make changes in the name of Registrations while they reside on a disk. You will first need to load them onto the unit, where you can then change their name before saving them onto the disk again.

## ● Calling Up a Registration That Was Saved (Load)

\* By calling up another Registration, the Registration currently in memory will be overwritten (erased).

1. Insert a floppy disk in the disk drive.
2. Press the Function button.
3. Using the Song Select button, select "Load Regist." Then press the Rec button.

```
Load Regist 0
Yes:REC
```

4. Using the Bwd/Fwd buttons, select the Registration you wish to load.

```
REGIST-01 USE
Load:REC </>/RST
```

5. To perform the load, press the Rec button.  
To cancel the procedure, press the Reset button.

---

## ● Erasing Registrations Saved on Disk (Delete)

1. Insert a floppy disk in the disk drive.
2. Press the Function button.
3. Using the Song Select button, select "Delete Regist." Then press the Rec button.

```
■Delete Regist ■  
Yes:REC
```

4. Using the Bwd/Fwd buttons, select the Registration you wish to delete.

```
REGIST-01 USE  
Del :REC */*/RST
```

5. To perform the delete, press the Rec button.  
To cancel the procedure, press the Reset button.

Once deleted, the word "USE" that appeared in the display will change to "---."

## ■ Handling the Disk Drive

- Avoid using the unit in areas of high humidity (eg., condensation). High levels of humidity can adversely affect the operation of the drive and/or damage floppy disks. When the unit has been transported, allow it to warm to room temperature before operating.
- To insert a disk, push it gently but firmly into the drive — it will click into place. To remove a disk, press the EJECT button firmly. Do not use excessive force to remove a disk which is lodged in the drive.

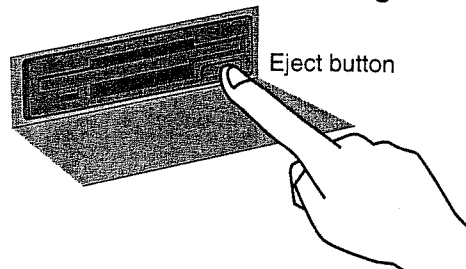

- Never attempt to remove a floppy disk from the drive while the drive is operating (the indicator is brightly lit); damage could result to both the disk and the drive.
- Remove any disk from the drive before powering up or down.

## ■ Handling Floppy Disks

- Floppy disks contain a magnetic storage medium (much like magnetic recording tape). Please observe the following when handling floppy disks:
  - Never touch the magnetic medium inside the disk.
  - Do not subject floppy disks to temperature extremes (eg., direct sunlight in an enclosed vehicle). Recommended temperature range: 10 to 50°C.
  - Do not expose floppy disks to strong magnetic fields, such as those generated by loudspeakers.
- Floppy disks contain a 'write protect' tab which can protect the disk from accidental erasure. It is recommended that the tab be kept in the 'PROTECT' position and moved to the 'WRITE' position only when you wish to write new data onto the disk.

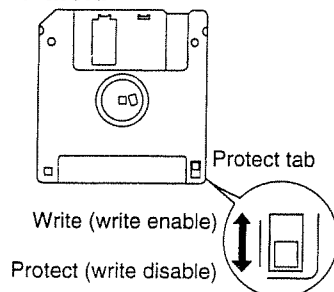

- All important data should be copied onto backup disk(s). This provides a complete duplicate of the data should the original disk(s) be lost or damaged.
- The identification label should be firmly fixed to the disk. Should the label come loose while the disk is in the drive, it may be difficult to remove the disk.
- Put the disk back into its case for storage.

## ■ Formatting Disks

Before any disk (new or used) can be used with the AT-70/50 it must first be formatted (prepared).

*\* Formatting a disk will erase any data that may have been stored on it. Carefully check any previously used disk to be sure it doesn't contain any valuable data.*

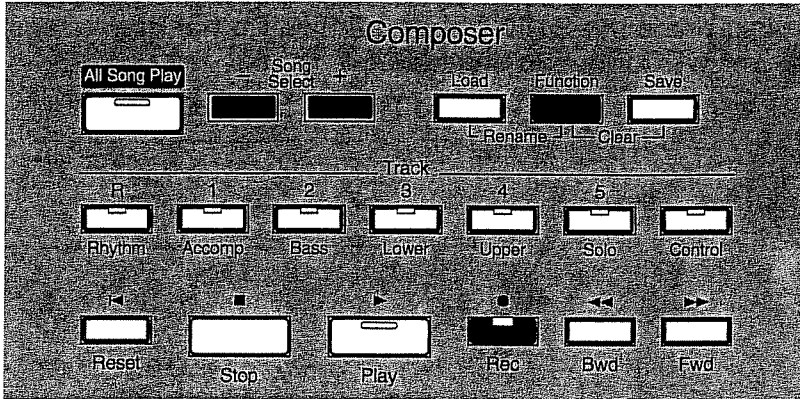

1. Slide the protect tab on the disk to the “Write” position.  
Insert the disk into the disk drive (label side up, shutter facing forward).

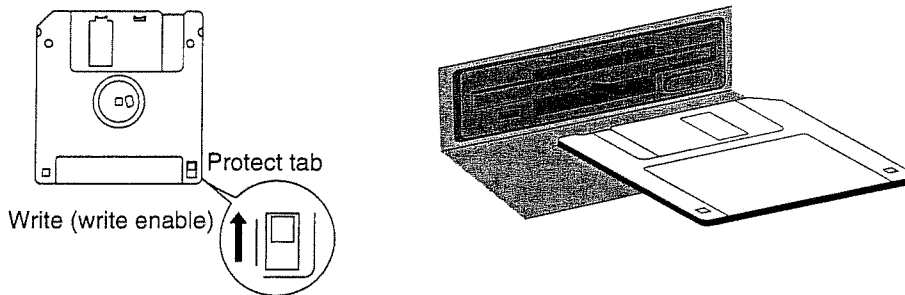

2. Press the Function button.
3. Select “Format Disk” using the Song Select button.

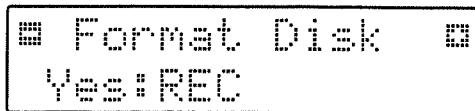

4. Press the Rec button.  
The following message, asking you to confirm, will be displayed.

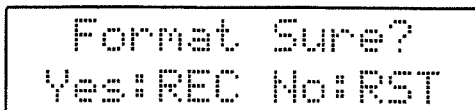

5. Press the Rec button again to perform the format.  
To cancel the procedure, press the Reset button.

The AT-70/50's Composer allows you to record (in digital form) what is played on the instrument.

## ■ Recording Performances (Rec Button)

The Composer provides seven Tracks.

You can record a different kind of performance data in each Track:

- Rhythm** : Rhythm performances, Manual Drums, Sound Effects
- Accomp** : Automatic accompaniment (except Bass)
- Bass** : Pedal Bass Voice, Bass part of the automatic accompaniment
- Lower** : Lower Voice
- Upper** : Upper Voice
- Solo** : Solo Voice
- Control** : Panel operations, Expression Pedal operations

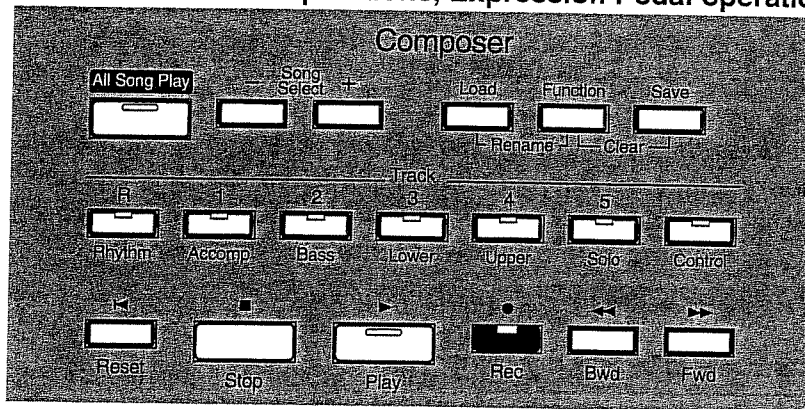

1. **Select the panel settings needed for recording the performance.**
2. **Press the Rec button to get into recording standby.**  
The Rec indicator lights, and the Play indicator begins to flash.
3. **Press the button for the Track you want to use for recording, and confirm that its indicator begins to flash.**

When recording a song for the first time, the indicators for all the Tracks automatically start flashing.

If some performance data has already been record into the specified Track (with the exception of the Control Track) that data will be erased as recording takes place.

#### 4. Press the Play button to start recording.

When you press the Play button the metronome will sound two measures of count-in before recording begins.

In the case of Rhythm performances and automatic accompaniment, recording begins at the same moment you start the Rhythm.

#### 5. Press the Stop button after you have completed recording.

The Track indicator for the track just recorded will light.

By pressing the Reset button instead of the Stop button, the unit resets (returns) to the beginning of the data just recorded.

*\* You cannot carry out recording when you have selected performance data from a source other than the AT-70/50 (SMF Music Data, ism music data).*

*Press the Rec button after having selected "NEW SONG" using the Song Select button. Or, remove the floppy disk from the disk drive.*

```
NEW SONG      :  
#120
```

*\* When you press the Intro/Ending button (or Start/Stop button) while recording a Rhythm performance or automatic accompaniment, the Rhythm performance and automatic accompaniment will stop. However, the recording itself will continue. Press the Stop button (or Reset button) to stop recording.*

*\* In the following instances, a message will be displayed:*

**When the instrument's memory is nearing capacity.**

```
Internal Memory  
Near Limit
```

**When recording was canceled because the memory limit was reached.**

```
Internal Memory  
is Full.
```

---

**You can also choose to cancel the metronome count-in before recording starts. (→ p. 64)**

---



## ■ Erasing Performance Data (Clear)

You will want to erase what was recorded when you are not satisfied with the result, and want to do the recording over again from the beginning, or when you want to make a completely new recording.

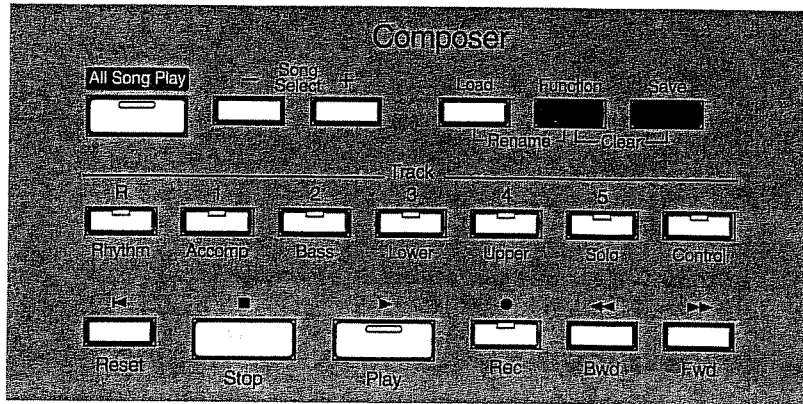

1. **Press the Function and Save buttons simultaneously.**

The following message, asking you to confirm your choice, will be displayed.

```
Clear Song Sure?  
Yes: CLEAR No: RST
```

2. **To erase the performance data, press the Function and Save buttons simultaneously.**

To cancel the procedure, press the Reset button.

## ■ Playing Back Performance Data (Play Button)

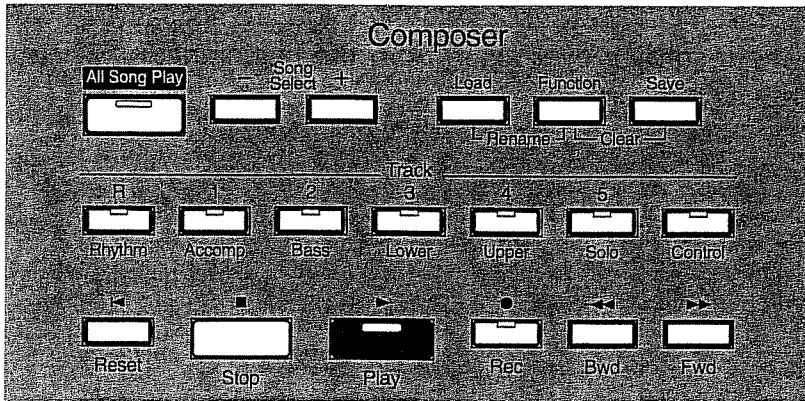

1. Press the Reset button to return to the beginning of the first measure.

When you want to play performance data from a specific point, use the Bwd and Fwd buttons to select the desired measure.

2. Press the Play button to start playback.
3. To stop playback at any point, press the Stop button (or Reset button).

*\* If you press the Play button while holding down the Stop button, the metronome will play two measures of count-in before playback starts.*

## ● Silencing a Specific Track (Track Mute)

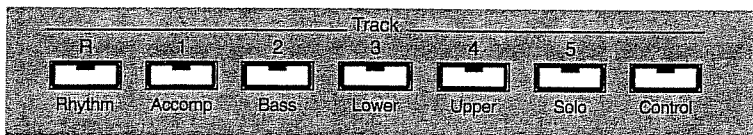

**Press a lit Track button and the indicator will go out.**

That Track has now been muted and will not be heard if the data is played back. Press the Track button again and that Track will be heard during playback. If all the Track indicators are dark, no sound at all will be heard during playback.

## ■ Saving Performance Data (Save Button)

The performance data that you record will be lost the instant you turn off the instrument. If you want to preserve your performance data, you need to save it onto a disk.

If performance data has never been saved onto disk, a "  " symbol appears in the display. (This symbol disappears once you save the data on disk.)



## ● Changing the Name of Performance Data (Rename)

A name is automatically assigned to the performance data that you record. However, you may want to change it to something more meaningful at some point.

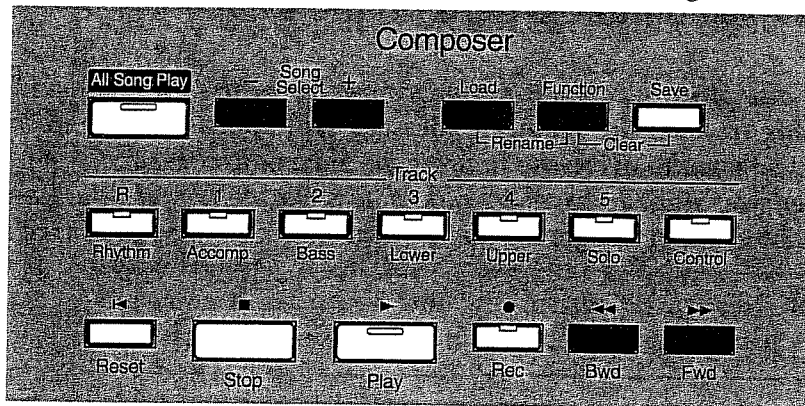

1. Press the Load and Function buttons simultaneously.
2. Get the character that you want to change to flash using the Song Select button. Then use the Bwd/Fwd buttons to change the character.

The characters which can be selected are as follows: -----  
0 1 2 3 4 5 6 7 8 9 space ! " # % & ' ( ) \* + , - . / : ; = ? ^ \_  
A B C D E F G H I J K L M N O P Q R S T U V W X Y Z  
a b c d e f g h i j k l m n o p q r s t u v w x y z

To delete a character, press the Load button. A space can be inserted by pressing the Save button.

3. When finished editing the name, simultaneously press the Load and Function buttons again.

\* You cannot directly change or edit the name of performance data stored on a disk. The data must first be loaded into the instrument, edited, and then saved to disk again.

## ● Saving Onto Disk (Save Button)

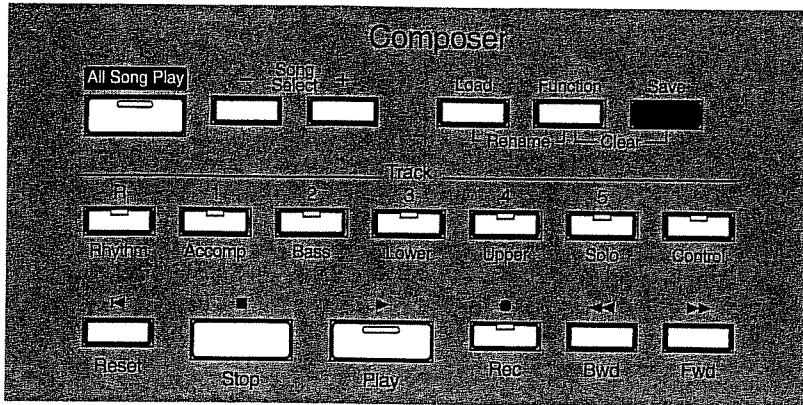

1. Insert a disk formatted on the AT-70/50 into the disk drive.
2. Press the Save button to perform the save.

\* When the disk already contains performance data with the same name as the data you're trying to save, the following message will appear. If you are just updating that data, and want to overwrite it, press the Save button again. If, however, you want to save the new data separately, press the Reset button to cancel the procedure, change the name of the new data, and then save it. (→ p. 49)

```
Overwrite Song ?  
Yes:SAVE No:RST
```

## ■ Loading Performance Data Into the Unit (Load Button)

To edit (→ p. 68, 69) or re-record performance data that is on disk, you must first load that data into the instrument.

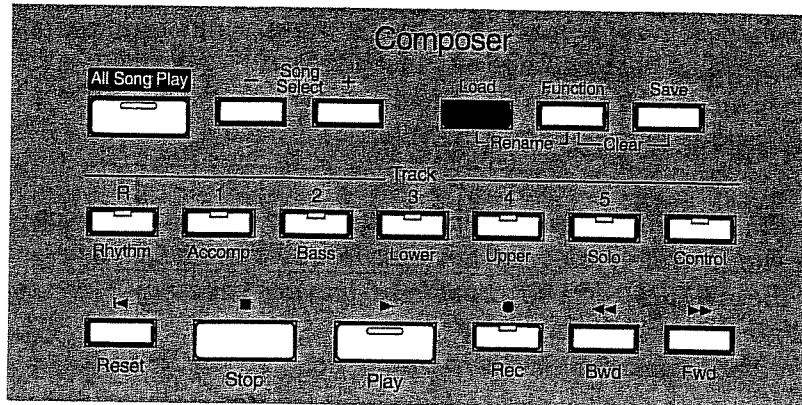

1. Insert the proper disk into the disk drive.
2. Press the Song Select button to select the performance data you wish to load.

\* *The message below is shown when the performance data in the unit has not been saved to disk. If you don't mind erasing it, press the Function and Save buttons at the same time. If you want to save this data, however, press the Reset button to cancel the procedure, and then save the data on disk. (→ p. 50)*

```
Clear Song Sure?  
Yes: CLEAR No: RST
```

3. Press the Load button (or Rec button) to carry out the load operation.

When you press the Rec button, the unit goes into recording standby after the data is loaded.

\* *You cannot load performance data from sources other than the AT-70/50 (SMF Music Data, ism music data).*

## ■ Playing Back Performance Data On Disk (All Song Play Button and Play Button)

The AT-70/50 not only provides for the playback of music that you recorded on disk, but it also allows you to enjoy playing a wide variety of commercially available music data, such as those listed below.

### SMF Music Data, ism music data

- \* *The Standard MIDI File format was designed to provide a means for exchanging performance data among a wide variety of devices. In addition to the types of music data shown above, the AT-70/50 is also capable of playing back any Standard MIDI Files compatible with the GM or GS formats.*
- \* *When the performance data is a Standard MIDI File, "\*" will be displayed after the file name.*

```
Take Five   *:#05
A180
```

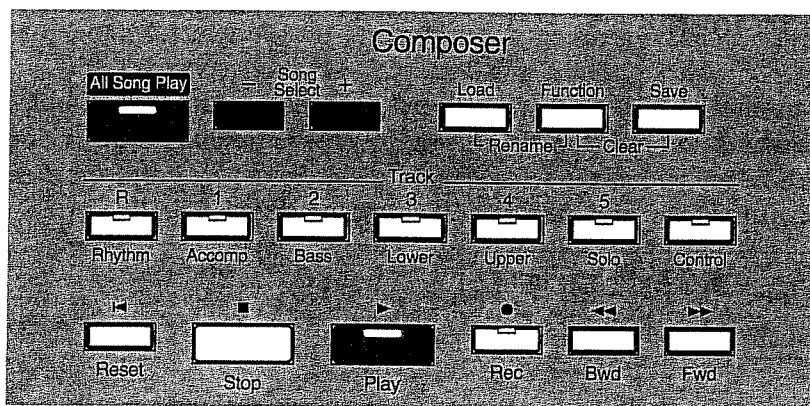

1. Insert the proper disk into the disk drive.
2. Press the Song Select button to select a song.

\* *To play back performance data from a disk, any data that may already be there must first be erased. The message below appears when there is some performance data already in the unit that has not been saved on disk. If you don't mind erasing it, press the Function and Save buttons simultaneously. If you do not want to lose this data, press the Reset button to cancel the procedure, and then save the data on disk. (→p. 50)*

```
Clear Song Sure?
Yes: CLEAR No: RST
```

3. When you want to play back all the performance data in order, press the All Song Play button. When you only want to play back one song, press the Play button.

#### 4. To stop playback, press the Stop button (or Reset button).

- \* When the All Song Play button was used to start playback, playback can also be stopped by pressing that button again.
- \* By holding down the Stop button when you press the Play button, you can have the metronome sound two measures of count-in before playback starts.
- \* When "Please Wait" is shown in the display, it means the unit is searching for performance data. Please wait until the message disappears.

```
Take Five *123
Please Wait.
```

### ■ Display/Exit Button

The instrument's display provides a large variety of information. Of note are the two "basic screens." These two screens can be switched between by pressing the Display/Exit button. Even when some other screen is displayed, one of these basic screens appears when you press the Display/Exit button.

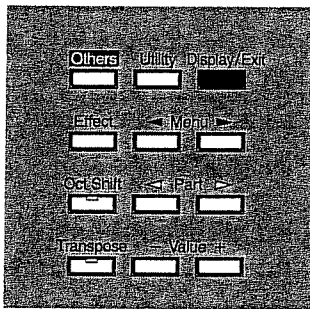

The information shown in the display is as follows:

#### Rhythm Screen:

Upper row : Rhythm Name

Lower row : Tempo/Name of Chord Played

```
Swing
♩:175 C Maj
```

#### Composer Screen:

Upper row : Song Name/Measure Number

Lower row : Tempo/Name of Chord Played

```
ATELIER-01 123
♩:175 C Maj
```

When you have selected performance data on disk, the "file number" is shown in place of the "measure number."

```
ATELIER-01 #01
♩:175 C Maj
```

## ■ Adjusting the Volume Balance (Part Balance Button)

The instrument allows you to adjust the volume balance individually for each Part.

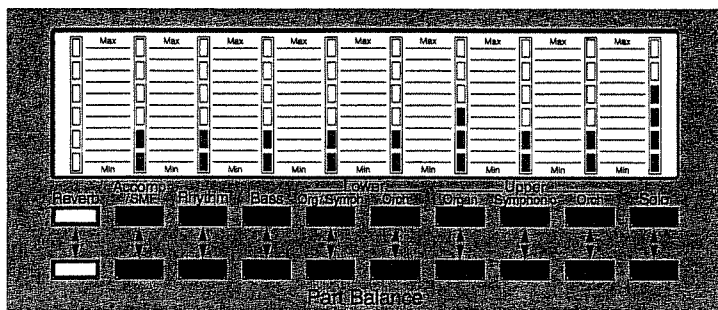

The various volume levels are adjusted using the corresponding buttons.

When you press the upper button (▲), the volume increases; when you press the lower button (▼), the volume decreases.

When all six segments of the indicator for any given Part are dark, that Part will produce no sound.

Note, however, that the following buttons are used to adjust the volume of a multiple number of Parts.

- Accomp/SMF button** : Automatic accompaniment (except bass)  
Playback of performance data from something other than the AT-70/50
- Rhythm button** : Rhythm performance, Manual Drums, Sound Effects
- Bass button** : Pedal Bass Voice, Bass part of automatic accompaniment
- Lower Org/Symph button** : Lower Organ, Lower Symphonic



## ■ Shifting the Pitch of Sound in Octave Units (Oct Shift Button)

Octave Shift is a function that allows you to alter the pitch of what is played by one or more octaves.

You can apply an octave shift to a total of seven Parts; all the Upper and Lower Parts (Organ/Symphonic/Orchestral), and the Solo Part.

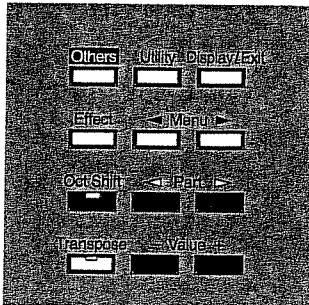

1. Press the Oct Shift button.
2. Press a Part button to select a performance Part to which you wish to apply an Octave Shift.

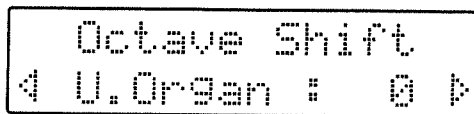

3. Use the Value buttons to make settings for the amount of shift.

The value can be set within the range of +/- 2 octaves. When any Part is set to any value other than 0, its indicator will light.

*\* Note that when you apply Octave Shifts to certain Voices, you can end up with situations where the lower or upper range has been shifted beyond the recommended note range. For this reason, they may not sound as expected.*

## ■ Transpose the Pitch (Transpose Button)

This function allows you to transpose the keyboard to another key. This lets you play in any key using the familiar fingering of the C major scale.

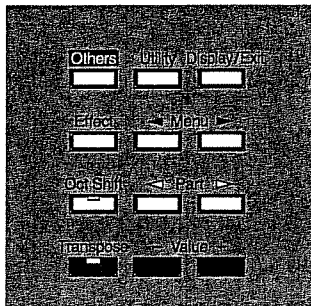

1. Press the Transpose button.
2. Set the transpose value using the Value button.

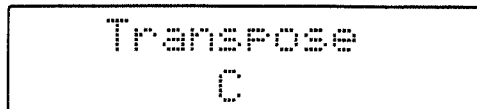

Acceptable values range from A flat to G (in semitone steps). When the transpose setting is anything other than C, the indicator will light.

*\* By pressing the + and - Value buttons simultaneously, you can restore the default setting (C).*

## ■ Settings for Effects (Effect Button)

Whenever needed, you can change the settings for the Reverb/Sustain/Rotary effects. There are five items (menus) which can be edited.

**Reverb Type**  
**Reverb Depth**  
**Sustain Length**  
**Rotary Speed**  
**Rotary Color**

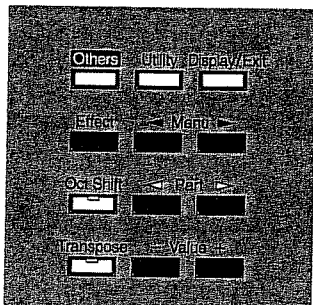

1. Press the Effect button.
2. Press the Menu button to select a menu.

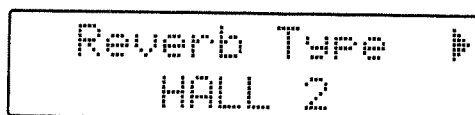

3. If the menu you selected provides for individual Part (section) settings, use the Part buttons to select the desired Part (section).

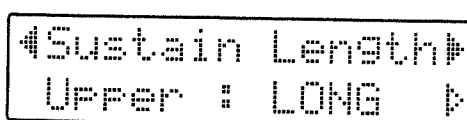
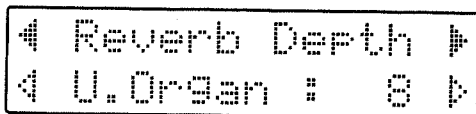

4. Use the Value buttons to set the desired value.

## ● Reverb Type

You can select from the following eight types of reverb:



- ROOM 1** : Reverberation of a small room
- ROOM 2** : Reverberation of a small club
- ROOM 3** : Reverberation of a large room
- HALL 1** : Reverberation of large concert hall
- HALL 2** : Reverberation of a small concert hall
- PLATE** : A bright, metallic reverberation
- DELAY** : An echo-like sound repeated several times
- PAN DELAY** : A delay which pans the sound back and forth between the left and right speakers

## ● Reverb Depth

The Reverb Depth can be set (0-10) individually for each of the following Parts.

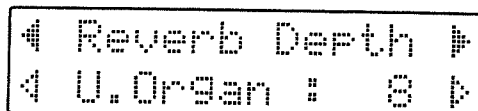

**Accomp, Rhythm, Manual Drums, Accomp Bass, Pedal Bass, Lower Organ, Lower Symphonic, Lower Orchestral, Upper Organ, Upper Symphonic, Upper Orchestral, Solo**

**Accomp** refers to automatic accompaniment (except Bass); while **Accomp Bass** is the bass for an automatic accompaniment.

## ● Sustain Length

The Sustain Length can be set (SHORT, MIDDLE, LONG) individually for each of the following three performance sections.

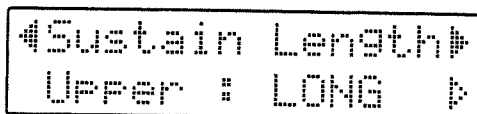

**Upper, Lower, Pedal Bass**

---

## ● Rotary Speed

This setting allows you to finely adjust the speed of the Rotary effect. You can select from the three available speeds (SLOW, NORMAL, FAST).

⌘ Rotary Speed ⌘  
NORMAL

*\* This setting remains stored in memory even while power is turned off.*

## ● Rotary Color

This setting allows you to choose the brightness of the sound (BRIGHT, MELLOW) you obtain when using the Rotary effect.

⌘ Rotary Color ⌘  
BRIGHT

*\* This setting remains stored in memory even while power is turned off.*

## ■ Various Other Settings (Utility Button)

You can make settings for the following 11 items (menus).

**Aftertouch (AT-70 only)**

**Initial Touch**

**Left Foot Switch Assignment (Selects function for left foot switch)**

**Right Foot Switch Assignment (Selects function for right foot switch)**

**Bender/Vibrato Destination (Setting for pitch bend/vibrato lever)**

**Pitch Bend Range**

**Manual Drums Set**

**Solo Split Point**

**Chord Hold**

**Master Tune**

**LCD Contrast (Display contrast)**

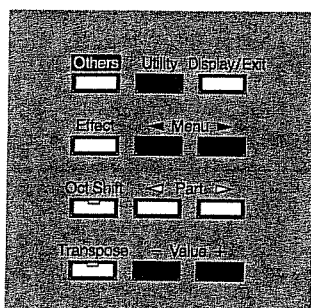

1. Press the Utility button.
2. Press the Menu button to select a menu.

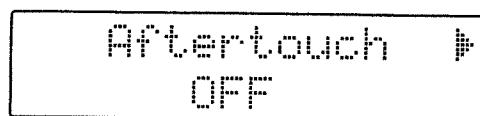

3. Use the Value buttons to set the desired value.

## ● Aftertouch (AT-70 Only)

This setting is used to turn ON/OFF the Aftertouch feature. (Aftertouch applies vibration when additional pressure is placed on keys that have been played.)

Aftertouch  
OFF

- \* *Aftertouch can be obtained only with the Upper keyboard on the AT-70.*
- \* *This setting remains stored in memory even while power is turned off.*
- \* *Please note that not all of the Voices are designed to provide for a response to aftertouch, even with this setting at ON.*

## ● Initial Touch

This setting is used to turn ON/OFF the Initial Touch feature. (It translates the force used to press keys into an equivalent amount of volume.)

Initial Touch  
ON

- ON : The harder you play, the higher the volume.  
OFF : Volume remains constant regardless of how hard you play

- \* *This setting remains stored in memory even while power is turned off.*

## ● Left Foot Switch Assignment/Right Foot Switch Assignment

You can select any of the following nine functions and assign them to the foot switches on both sides of the expression pedal.

Left Foot Sw  
GLIDE

Right Foot Sw  
ROTARY FAST/SLOW

- \* *You cannot assign the same function to both the left and right switches.*

GLIDE  
ROTARY FAST/SLOW  
LEADING BASS  
RHYTHM START/STOP  
COMPOSER PLAY/STOP  
INTRO/ENDING  
FILL IN TO VARIATION  
FILL IN TO ORIGINAL  
ADVANCED/BASIC  
DAMPER OF UPPER

### GLIDE:

This feature temporarily lowers the pitch, then gradually returns it to what it was originally.

### LEADING BASS:

The Leading Bass function will be active only while you are pressing the switch.

### COMPOSER PLAY/STOP:

The switch will serve as a Play button/Stop button for the Composer. Performance data will either start playing or stop with each press of the switch.

### DAMPER OF UPPER:

While the switch is pressed, only the sound played using the Upper keyboard will be sustained.

The action obtained with the other items will be the same as pressing the relevant buttons on the panel.

## ● Bender/Vibrato Destination

This setting specifies which Section (from the following three) you want to have the effect applied to when you operate the Pitch Bend/Vibrato lever.

◀Bender/Vibrato▶  
to UPPER

**UPPER** : The effect is applied to what is played on the Upper keyboard.

**LOWER** : The effect is applied to what is played on the Lower keyboard.

**PEDAL BASS** : The effect is applied to what is played on the Bass keyboard.

## ● Pitch Bend Range

This setting allows you to choose the maximum amount of change (range) permissible when using pitch bend. The range can be set anywhere between 1-12 (in semi-tone units; maximum of one octave).

◀PitchBendRange▶  
2

\* *Manual Drums and Sound Effects are fixed at one octave, regardless of this setting.*

## ● Manual Drums Set

This setting allows you to choose one of the following eight Drum Sets.

◀ManualDrumsSet▶  
STANDARD

STANDARD  
ROOM  
POWER  
ELECTRONIC  
808  
JAZZ  
BRUSH  
ORCHESTRA



## ●Solo Split Point

This setting is used to set the Solo Split Point (lower limit of the playable range of the Solo Voice) of the Lower keyboard to any desired position.

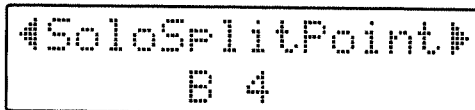

◀SoloSplitPoint▶  
B 4

AT-70 : E1 to G7

AT-50 : C2 to C7

\* *By simultaneously pressing the + and - Value buttons, you can restore the default setting B4.*

## ●Chord Hold

Chord Hold can be switched ON/OFF. Chord Hold is a function which allows you to play automatic accompaniment.

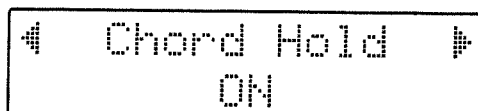

◀ Chord Hold ▶  
ON

ON : The chord that was played on the Lower keyboard is sustained (even if you release the keys), and automatic accompaniment continues.

OFF : When you release the keys that you played in the Lower keyboard, the automatic accompaniment pauses. Only the Rhythm performance will continue.

## ●Master Tune

This function allows the master tuning to be set at any value between 415.3 Hz and 466.2 Hz. The instrument accepts settings in increments of 0.1 Hz.

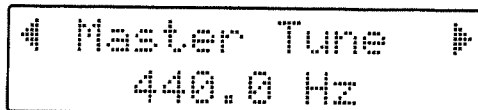

◀ Master Tune ▶  
440.0 Hz

\* *By pressing the + and - Value buttons simultaneously, you can restore the default setting (440.0 Hz).*

\* *This setting remains stored in memory even while power is turned off.*

## ● LCD Contrast

This setting allows you to adjust the contrast of the display. (Available settings: 1-10)



◀ LCD Contrast  
5

\* *This setting remains stored in memory even while power is turned off.*

## ■ Settings for the Composer (Function Button)

### ● Count-In Recording

This setting (ON/OFF) determines whether or not a metronome count-in (2 measures) will be heard after pressing the Play button on recording. (The count-in helps you establish the tempo before you begin playing.)

1. Press the Function button.
2. Using the Song Select button, select “Count-In Rec.”

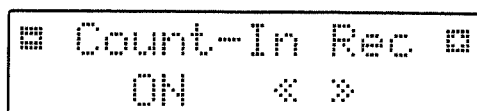

■ Count-In Rec ■  
ON ⌘ ⌘

3. Use the Bwd/Fwd buttons to turn it ON or OFF.

### ● Metronome

This setting determines whether or not the metronome will sound.

Heard only while recording	: REC
Heard during recording and playback	: ON
Not heard at all	: OFF

1. Press the Function button.
2. Using the Song Select button, select “Metronome.”



■ Metronome ■  
OFF ⌘ / ⌘

3. Use the Bwd/Fwd buttons to select REC, ON, or OFF.

\* When recording Rhythm performances or automatic accompaniment, the metronome will not sound (the setting made here is ignored).

## ● Metronome Volume

Carry out the steps below to adjust the volume of the metronome.

1. Press the Function button.
2. Using the Song Select button, select “Metronome Vol.”



Metronome Vol.  
10 </>

3. Press the Bwd/Fwd buttons to select the desired volume level (1-10).

## ● Setting for the Beat

This setting determines the beat (time signature) to be used when recording performances.

Numerator : 1 or more (denominator x 2-1)  
Denominator : 2, 4, 8, 16

1. Press the Function button.
2. Select “Beat” using the Song Select button.

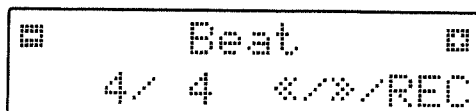

Beat  
4/4 </>/REC

3. Use the Bwd/Fwd buttons to set the numeric value for the numerator. Use the Rec button to move the cursor from the numerator to the denominator (and back again if necessary).

- \* When recording Rhythm performances or automatic accompaniment, the beat is set automatically.
- \* You cannot change the beat of previously recorded data.

---

## ● Erasing Performance Data

Follow the steps below to erase performance data that was saved on a disk.

1. Insert the disk into the disk drive.
2. Press the Function button.
3. Select “Delete Song” using the Song Select button, then press the Rec button.

```
■ Delete Song ■  
Yes:REC
```

4. Using the Bwd/Fwd buttons, select the performance data to be erased.
5. Press the Rec button.

You will see the following:

```
ATELIER-01 :01  
Del Sure?REC/RST
```

6. To go ahead with the erasure, press the Rec button again.  
To cancel the procedure, press the Reset button.

---

## ● Erasing a Track's Performance Data

Follow the steps below to erase the performance data recorded in a specific Track.

1. Press the Function button.
2. Select "Delete Track" using the Song Select button.

```
■ Delete Track ■  
DRUMS    </>/REC
```

3. Using the Bwd/Fwd buttons, select the Track from which you want to erase the data.
4. Press the Rec button.

You should see the following:

```
Delete DRUMS ?  
Yes:REC No:RST
```

5. To proceed with the erasure, press the Rec button again.  
To cancel the procedure, press the Reset button.

## ● Copying Performance Data

This function allows you to copy a specified portion of performance data and put it into some other measure within the same Track.

1. Press the Function button.
2. Using the Song Select button, select "Copy."

```

  Copy
from: 1 */*/REC

```

3. Use the Bwd/Fwd buttons to specify the desired value, then press the Rec button/Reset button to switch the screen to the next item that needs to be set.

The settings are as follows:

from : First measure  
for : Number of measures from first measure  
to : Measure number at copy destination  
time : Number of copies to make

For example, if you wish to make two copies of measures 4-12, and have those two copies be placed after the last measure, you would make these settings:

```

from : 4
for : 9
to : END
time : 2

```

If you wanted to copy all the measures up to the end, you would select "for: ALL."

When you press the Rec button after making the setting for "time," the content of all the settings will be displayed.

```

4: 9:END: 2
Yes:REC No:RST

```

4. To proceed with making the copy, press the Rec button again.  
To cancel the procedure, press the Reset button.

## ● Quantize

Quantize corrects any timing errors that may have been made during recording.

1. Press the Function button.
2. Using the Song Select button, select "Quantize."

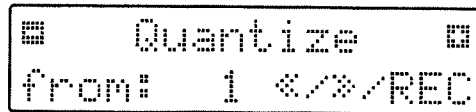

3. Use the Bwd/Fwd buttons to specify the desired value, then press the Rec button/Reset button to switch the screen to the next item that needs to be set.

The settings are as follows:









**From** : First measure  
**For** : Number of measures from first measure  
**Res** : Timing at which notes are to be aligned (resolution). (If the shortest notes in your song are eighth notes, for example, set the resolution to "8". If the shortest notes in your song are sixteenth notes, set the resolution to "16".)

For example, if you wanted to quantize measures 4-12 to a sixteenth note resolution, you would select these settings:

from : 4  
 for : 9  
 Res : 16

If you wanted to specify all the measures up to the end, you would select "for: ALL."

The following choices are available for "Res":

2		half-note	12		eighth-note triplet
4		quarter-note	16		sixteenth-note
6		quarter-note triplet	24		sixteenth-note triplet
8		eighth-note	32		thirty-second note

If you press the Rec button after making the setting for Res, the content of all the settings will be displayed.

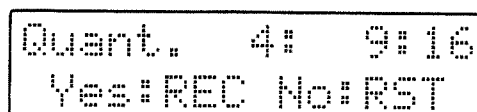

4. To perform Quantization, press the Rec button again.  
 To cancel the procedure, press the Reset button.

---

## ● Channel Mute

This function allows you to mute performance data on an individual channel basis.

\* *Channel Mute is effective only while the menu is displayed.*

1. Press the Function button.
2. Press the Song Select button to select "Ch. Mute."



■Ch. Mute\*/\*/REC  
1234567890123456

3. Using the Bwd/Fwd buttons, select the channel you wish to Mute.

From the left, they are: 1Ch, 2Ch.....15Ch, 16Ch.

4. Press the Rec button.



■Ch. Mute\*/\*/REC  
-234567890123456

The number changes to "-" showing that it is muted.

The mute function can be released by pressing the Rec button again.



- When you press the POWER switch, power doesn't come on. ....
  - Power cord is not connected correctly (→ p. 14).
  
- Sound Is Not Produced .....
  - The Master Volume slider is set too low (→ p. 15).
  - Headphones are connected (→ p. 12).
  - The volume is set too low as a result of the Part Balance buttons (→ p. 54).
  - The volume is set too low because of the expression pedal (→ p. 15, 27).
  - You do not have a Voice selected (→ p. 17-19).
  - The stand's speaker cord or pedal cord are not connected correctly (→ p. 84).
  
- Pedals Don't Work .....
  - The stand's pedal cord is not properly connected (→ p. 84).
  - The damper pedal affects only the Lower keyboard. It won't work for the Upper keyboard and Pedal keyboard (→ p. 28).
  - While playing back performance data containing data directed at the expression pedal, the pedal will not be able to provide its normal response when you step on it.
  
- When you release your fingers from keys in the Lower keyboard while Automatic Accompaniment + Rhythm is playing, the rhythm performance alone remains playing. ....
  - Chord Hold is at OFF (→ p. 63).
  
- When you release your fingers from keys in the Lower keyboard, the notes continues sounding. ....
  - Lower Voice Hold is at ON (→ p. 38).
  
- Even though you press only one key, a multiple number of notes sound. ....
  - Melody Intelligence is at ON (→ p. 27).
  - Chord Intelligence is turned ON (→ p. 37).
  
- Automatic Accompaniment Sounds Odd .....
  - The keys for a chord were not pressed simultaneously.
  - Even though Chord Intelligence is OFF, you think it is ON, and are abbreviating chords (→ p. 37).

- 
- Pitch Is Off .....
    - A transpose is in effect (→ p. 56).
    - The tuning is incorrect (→ p. 63).
    - While set for an octave shift, you are playing keys beyond the recommended range. This does not indicate a malfunction (→ p. 55).
  
  - Performance Data Cannot Be Played Back .....
    - While the Function menu appears in the display (with the exception of Channel Mute), playback is not allowed.
  
  - Cannot Record .....
    - While the Function menu appears in the display, recording is not allowed.
  
  - Sound of Metronome Is Strange .....
    - If the metronome is sounded while a Standard MIDI File is played back, the metronome can sometimes sound different than usual. This does not indicate a malfunction.

■ Save Regist ■  
Can't Execute.

■ Load Regist ■  
Can't Execute.

■ Delete Regist ■  
Can't Execute.

■ Delete Song ■  
Can't Execute.

**Cause:**

A disk is not inserted in the disk drive.

**Solution:**

Insert a disk in the drive, then try the procedure again.

Can't Load  
This Song.

**Cause:**

You tried to load performance data that was not created by the AT-70/50. Performance data from sources other than the AT-70/50 cannot be loaded.

Can't Modify  
This Song.

**Cause:**

By pressing the Rec button, you have loaded performance data not created by the AT-70/50, and then have attempted to go into recording standby. Performance data from sources other than the AT-70/50 cannot be recorded.

Can't Play  
This Song.

**Cause:**

- The performance data is excessively large, so it cannot be played back.
- You cannot play back performance data in Standard MIDI File Format I that contains more than 16 tracks.

Can't Save  
onto This Disk.

**Cause:**

- You cannot save performance data on disks containing Standard MIDI Files.
- You cannot save performance data on master disks.
- You cannot save performance data on disks formatted for MS-DOS.

**Solution:**

Insert a disk formatted on the AT-70/50 into disk drive, then try the procedure again.

Can't Save  
This Song.

**Cause:**

The performance data you are attempting to save contains data designed to prevent unauthorized copying. As a result, it cannot be saved onto disk.

Clear Song Sure?  
Yes: CLEAR No: RST

**Cause:**

To carry out the procedure, you first need to erase performance data in the unit. This message asks you to confirm that you don't mind doing this.

**Solution:**

To erase the data, simultaneously press both the Function and Save buttons. When you do not want to erase it, press the Reset button, then save the data on disk.

Disk Problem  
has Occurred.

**Cause:**

The data transfer could not be processed correctly.

**Solution:**

Try taking out, then inserting the disk again (or replace the disk with a different one), then try the procedure over again.

Factory Setup  
is Loaded.

**Cause:**

The internal settings were lost (Registrations, etc.) because the instrument was not turned on for about a month.

**Solution:**

The basic display will appear after the instrument has been returned automatically to all the factory default settings.

Improper Card:  
Insert TN5C2Card

**Cause:**

The card that you inserted cannot be handled by the AT-70/50.

**Solution:**

Replace it with an appropriate Music Style Card (TN-SC2 series).

Improper Disk:  
Please Format.

**Cause:**

- The disk is one that was used with some other device.
- The disk is brand new, and has not been formatted yet.

**Solution:**

Format the disk according to the steps on page. 44.

Format  
Insert New Disk.

**Cause:**

A disk is not inserted in the disk drive.

**Solution:**

Insert a disk to be formatted into disk drive, then try the procedure again.

Internal Memory  
is Full.

**Cause:**

Because the unit's memory is full to capacity, recording was canceled.

---

Internal Memory  
Near Limit

Situation:

The unit is warning you that its memory will soon become full to capacity, so not much more recording can be done.

No Room  
on Disk

Cause:

- Because the disk is full, nothing further can be stored on it.
- Up to a maximum of 99 songs (MF2HD), or 56 songs (MF2DD) can be stored on disk.

Solution:

Replace the disk with a different one, or erase some of the data that is on the disk.

Overwrite Song ?  
Yes: Save No: RST

Cause:

There already is performance data having the same name on the disk.

Solution:

To replace the existing data with the new version, once again press the Save button. To save it as a separate new file, press the Reset button first. Then, after changing the name (→ p. 49), save it on disk.

Write-Protected  
Disk

Cause:

The disk's protect tab is at the "ON" position.

Solution:

Slide the disk's protect tab to the "OFF" position, and do the procedure over again.

# Drum Set List

Note No.	STANDARD/JAZZ	ROOM	POWER	ELECTRONIC	TR-808	BRUSH	ORCHESTRA
28	Slap						Pedal Hi-Hat [EXC1]
29	Scratch Push						Open Hi-Hat [EXC1]
30	Scratch Pull						Ride Cymbal
31	Sticks						
32	Square Click						
33	Metronome Click						
34	Metronome Bell						
35	Kick Drum 2						Concert BD 2
C2 36	Kick Drum 1		MONDO Kick	Elec BD	808 Bass Drum		Concert BD 1
37	Side Stick				808 Rim Shot		
38	Snare Drum 1		Gated SD	Elec SD	808 Snare Drum	Brush Tap	Concert SD
39	Hand Clap					Brush Slap	Castanets
40	Snare Drum 2			Gated SD		Brush Swirl	Concert SD
41	Low Tom 2	Room Low Tom 2	Room Low Tom 2	Elec Low Tom 2	808 Low Tom 2		Timpani F
42	Closed Hi-Hat [EXC1]				808 CHH [EXC1]		Timpani F#
43	Low Tom 1	Room Low Tom 1	Room Low Tom 1	Elec Low Tom 1	808 Low Tom 1		Timpani G
44	Pedal Hi-Hat [EXC1]				808 CHH [EXC1]		Timpani G#
45	Mid Tom 2	Room Mid Tom 2	Room Mid Tom 2	Elec Mid Tom 2	808 Mid Tom 2		Timpani A
46	Open Hi-Hat [EXC1]				808 OHH [EXC1]		Timpani A#
47	Mid Tom 1	Room Mid Tom 1	Room Mid Tom 1	Elec Mid Tom 1	808 Mid Tom 1		Timpani B
C3 48	High Tom 2	Room Hi Tom 2	Room Hi Tom 2	Elec Hi Tom 2	808 Hi Tom 2		Timpani c
49	Crash Cymbal 1				808 Cymbal		Timpani c#
50	High Tom 1	Room Hi Tom 1	Room Hi Tom 1	Elec Hi Tom 1	808 Hi Tom 1		Timpani d
51	Ride Cymbal 1						Timpani d#
52	Chinese Cymbal			Reverse Cymbal			Timpani e
	Ride Bell						Timpani f
53	Tambourine						
55	Splash Cymbal						
56	Cowbell				808 Cowbell		
57	Crash Cymbal 2						Concert Cymbal 2
58	Vibra Slap						
59	Ride Cymbal 2						Concert Cymbal 1
C4 60	High Bongo						
61	Low Bongo						
62	Mute High Conga				808 High Conga		
63	Open High Conga				808 Mid Conga		
64	Low Conga				808 Low Conga		
	High Timbale						
65	Low Timbale						
67	High Agogo						
68	Low Agogo						
69	Cabasa						
70	Maracas				808 Maracas		
71	Short Hi Whistle [EXC2]						
C5 72	Long Low Whistle [EXC2]						
73	Short Guiro [EXC3]						
74	Long Guiro [EXC3]						
75	Claves				808 Claves		
76	High Wood Block						
	Low Wood Block						
77	Mute Cuica [EXC4]						
79	Open Cuica [EXC4]						
80	Mute Triangle [EXC5]						
81	Open Triangle [EXC5]						
82	Shaker						
83	Jingle Bell						
C6 84	Belltire						
85	Castanets						
86	Mute Surdo [EXC6]						
87	Open Surdo [EXC6]						
88							Applause

Blank : same percussion instruments as the Standard Set

--- : no sound

[EXC] : will not sound simultaneously with other percussion instruments of the same number

\* The percussive sounds for the keys E1 through B1 (Note Nos. 28-35) will not sound on the AT-50.

Note No.	Sound Effects
39	High Q
40	Slap
41	Scratch Push
42	Scratch Pull
43	Sticks
44	Square Click
45	Metronome Click
46	Metronome Bell
47	Guitar sliding finger
C3 48	Guitar cutting noise (down)
49	Guitar cutting noise (up)
50	String slap of double bass
51	Fl. Key Click
52	Laughing
	Screaming
53	Punch
54	Heart Beat
55	Footsteps1
56	Footsteps2
57	Footsteps2
58	Applause
59	Door Creaking
C4 60	Door
61	Scratch
62	Windchime
63	Car-Engine
64	Car-Stop
	Car-Pass
65	Car-Crash
66	Siren
67	Train
68	Jetplane
69	Helicopter
70	Starship
71	Starship
C5 72	Gun Shot
73	Machine Gun
74	Lasergun
75	Explosion
76	Dog
	Horse-Gallop
77	Birds
78	Rain
79	Thunder
80	Thunder
81	Wind
82	Seashore
83	Stream
C6 84	Bubble

Function...	Transmitted	Recognized	Remarks
Basic Channel Default Changed	11, 12, 13	1 — 16	
Mode Default Messages Altered	x x *****	Mode 3 Mode 3, 4(M=1)	* 2
Note Number : True Voice	28—105(AT-70), 36—96(AT-50) *****	0 — 127 0 — 127	
Velocity Note ON Note OFF	O * 1 x	O x	
After Touch Key's Ch's	x x	O O	
Pitch Bend	x	O	
Control Change	0, 32 x 1 x 5 x 6, 38 x 7 x 10 x 11 x 64 O 65 x 66 x 67 x 84 x 91 x 93 x 98, 99 x 100, 101 x	O O O O O O O O O O O O (Reverb) O (Chorus) O O	Bank select Modulation Portamento time Data entry Volume Panpot Expression Hold 1 Portamento Sostenuto Soft Portamento control Effect1 depth Effect3 depth NRPN LSB, MSB RPN LSB, MSB
Prog Change : True #	x *****	O 0 — 127	Prog. 1—128
System Exclusive	x	O	
System Common : Song Pos : Song Sel : Tune	x x x	x x x	
System Real Time : Clock : Commands	x x	x x	
Aux Message : All sound off : Reset all controllers : Local ON/OFF : All Notes OFF : Active Sense : Reset	x x x x O x	O (120, 126, 127) O x O (123 — 127) O x	
Notes	* 1 O x is selectable. * 2 Recognized as M=1 even if M≠1.		

Mode 1 : OMNI ON, POLY    Mode 2 : OMNI ON, MONO  
Mode 3 : OMNI OFF, POLY    Mode 4 : OMNI OFF, MONO

O : Yes  
X : No



## Roland Organ Atelier AT-70/50

### ● Keyboard .....

#### AT-70 :

Upper 56Keys Lower 76Keys Pedal Bass 13 Keys

#### AT-50 :

Upper 49Keys Lower 61Keys Pedal Bass 13 Keys

### ● Voice (Total 128 Voices) .....

#### <Upper Voice>

##### Organ :

Full, Jazz, Rock, Pipe, Theater, Others

##### Symphonic :

Strings, Slow Strings, Synth Strings, Synth Pad, Choir, Others

##### Orchestral :

Piano, E.Piano, A.Guitar, E.Guitar, Brass, Harpsi, Harp, Vibes, Marimba, Mandolin, Banjo, Accordion, Harmonica, Others

#### <Lower Voice>

##### Organ :

Full, Lower, Pipe, Theater, Others

##### Symphonic :

Strings, Synth Strings, Choir, Others

##### Orchestral :

Piano, E.Piano, A.Guitar, Brass, Harpsi, Harp, Vibes, Marimba, Accordion, Harmonica, Others

#### <Solo Voice>

Violin, Trumpet, Sax, Flute, Oboe, Clarinet, Others

#### <Pedal Bass Voice>

Organ, Pipe Organ, String, Electric, Others

*\* Each keyboard can get access to all preset 128 voices with the "Others" button.*

### ● Number of Accompaniment/SMF

Play Voices .....  
226 Voices

### ● Effect.....

Rotary Sound, Chorus, Reverb, Sustain, Vibrato, Pitch Bend, Glide

### ● Rhythm .....

(Total 64 Rhythms, Variation/Original)  
Swing, Jazz, Dixie, Country, 50's, Ballad, Classical, Waltz, Bossa Nova, Latin, Comtemporary, Pops, Soul, March, Others

*\* 34 Rhythms are accessible with the "Others" button.*

*\* Music Style Cards (sold separately; TN-SC2 series) can provide additional Music Styles.*

### ● Number of Manual Drums Sets.....

8 Sets

### ● Number of Sound Effects Sets.....

1 Set

### ● Arranger Function .....

Arranger On/Off, Chord Intelligence, Leading Bass, Advanced/Basic, Melody Intelligence, One Touch Program

### ● Number of Registration Memories .....

AT-70 :12

AT-50 :8

## ● Composer .....

Tracks : 7  
Note Storage : approx. 40,000 notes  
(Max. 999 measures)  
Recording : Realtime

## ● Storage .....

3.5 inch Micro Floppy Disk

Disk Format:  
720K bytes(MF2DD)  
1.44M bytes(MF2HD)

Songs:  
max. 56(MF2DD)  
max. 99(MF2HD)

## ● Disk Drive.....

3.5 inch Micro Floppy Disk Drive  
(MF2DD/MF2HD)

## ● Display .....

16 characters, 2 lines (backlit LCD)

## ● Connectors .....

Phone Jack(Stereo)  
AC Inlet  
Speaker Connector  
Pedal Connector  
MIDI Connectors(In/Out)  
Audio Input Jacks(L(MONO)/R)  
Audio Output Jacks(L(MONO)/R)

## ● Pedals.....

Damper Pedal  
Expression Pedal (with two assignable foot switches)

## ● Speakers .....

### <AT-70>

(Stand) : 30cm x 1, 16cm x 4  
(Body) : 8cm x 2

### <AT-50>

(Stand) : 25cm x 1, 16cm x 2  
(Body) : 8cm x 2

## ● Rated Power Output.....

AT-70 : 60W + 60W + 120W  
AT-50 : 40W + 40W + 80W

## ● Power Supply .....

AC117V, AC230V or AC240V

## ● Power Consumption.....

AT-70 : 377W(AC117V),  
286W(AC230V),  
286W(AC240V)  
AT-50 : 242W(AC117V),  
182W(AC230V),  
182W(AC240V)

## ● Finish .....

Traditional Wallnut

## ● Dimensions.....

### <AT-70>

Body:  
1324(W) x 605(D) x 307(H) mm  
(Including Music Rest)  
52-1/8(W) x 23-7/8(D) x 12-1/8(H) inches

Stand:  
1316(W) x 594(D) x 718(H) mm  
51-13/16(W) x 23-7/16(D) x 28-5/16(H)  
inches

Total:  
1324(W) x 605(D) x 1025(H) mm  
52-1/8(W) x 23-7/8(D) x 40-7/16(H) inches

## <AT-50>

Body:

1230(W) x 605(D) x 307(H) mm

(Including Music Rest)

48-7/16(W) x 23-7/8(D) x 12-1/8(H) inches

Stand:

1210(W) x 594(D) x 718(H) mm

47-11/16(W) x 23-7/16(D) x 28-5/16(H)

inches

Total:

1230(W) x 605(D) x 1025(H) mm

48-7/16(W) x 23-7/8(D) x 40-7/16(H) inches

## ● Weight.....

### <AT-70>

Body : 58.0kg / 128 lbs 14 oz

Stand : 66.0kg / 145 lbs 9 oz

Total : 124.0kg / 273 lbs 7 oz

### <AT-50>

Body : 50.0kg / 110 lbs 4 oz

Stand : 53.0kg / 116 lbs 14 oz

Total : 103.0kg / 227 lbs 2 oz

## ● Accessories.....

Stool

AT-70 : TYPE A

AT-50 : TYPE B

Owner's Manual

3.5 inch Micro Floppy Disk(MF2HD)

Power Cord

## ● Options.....

Music Style Card(TN-SC2 series)

*\* In the interest of product development, the specifications and/or appearance of this product are subject to change without prior notice.*

<b>A</b>	
Advanced .....	36
Aftertouch.....	61
All Song Play .....	52
Alternate Rhythm .....	29
Alternate Voice	
Lower.....	17
Solo .....	19
Upper .....	17
Arrangement.....	34, 36
Arranger .....	35
Automatic Accompaniment .....	35
<b>B</b>	
Basic Screen .....	53
Beat .....	65
Beat Indicator .....	33
Break.....	34
Brilliance .....	26
Bwd .....	48
<b>C</b>	
Channel Mute.....	70
Chord .....	37
Chord Hold .....	63
Chord Intelligence .....	37
Chorus.....	23
Clear .....	47
Composer .....	45
Contrast.....	63
Copy .....	68
Count-In Recording .....	64
<b>D</b>	
Damper Pedal.....	28
Delete	
Performance Data .....	66
Registration .....	42
Display .....	53, 63
Drums .....	22
<b>E</b>	
Effect .....	57
Ending .....	36
Erase	
Performance Data .....	47
Track's Performance Data.....	67
Expression Pedal.....	15, 27
<b>F</b>	
File Number .....	53
Fill-In.....	34
Floppy Disk .....	43
Foot Switches .....	28, 61
Format .....	44
Function .....	64
Fwd .....	48
<b>G</b>	
Glide .....	28, 61
<b>I</b>	
Initial Touch.....	61
Intro .....	36
<b>L</b>	
Leading Bass .....	38
Load	
Performance Data .....	51
Registration .....	41
Lower .....	17
Lower Voice Hold.....	38
<b>M</b>	
Manual .....	39
Manual Drums.....	22
Manual Drums Set.....	62
Master Tune .....	63
Melody Intelligence.....	27
Metronome.....	64
Metronome Volume.....	65
Music Style Card.....	31
<b>N</b>	
NEW SONG .....	46
<b>O</b>	
Octave Shift.....	55
Octave Up.....	18
One Touch Program.....	35
Original .....	34
Others	
Rhythm .....	30
Voice.....	20

<b>P</b>	
Part Balance .....	54
Pedal Bass .....	18
Pitch Bend .....	26
Pitch Bend Range .....	62
Pitch Bend/Vibrato lever .....	26, 62
Play Back.....	48, 52
Protect Tab.....	44

<b>Q</b>	
Quantize .....	69

<b>R</b>	
Recording.....	45
Registration	
Call Up .....	39, 41
Delete .....	42
Save .....	40
Store .....	39
Rename .....	49
Resolution .....	69
Reverb.....	24
Reverb Depth .....	58
Reverb Type.....	58
Rhythm.....	29
Rhythm Performances.....	35
Rotary.....	25
Rotary Color .....	59
Rotary Speed .....	59

<b>S</b>	
Save	
Performance Data .....	49
Registration .....	40
Solo .....	19
Solo Split Point.....	19, 63
Sound Effects .....	22
Standard MIDI File.....	52
Start	
Recording .....	45
Rhythm .....	32
Stop	
Recording .....	46
Rhythm .....	32
Sustain.....	24
Sustain Length .....	58
Sync Start.....	32

<b>T</b>	
Tempo .....	33
To Lower	
Bass .....	18
Solo .....	19
Track .....	45
Track Mute.....	48
Transpose.....	56

<b>U</b>	
Upper .....	17
Utility .....	60

<b>V</b>	
Variation .....	34
Vibrato.....	26
Voice	
Bass .....	18
Lower.....	17
Solo .....	19
Upper .....	17
Volume.....	15
Volume Balance .....	54

<b>W</b>	
Write .....	39

# Setting up the AI-70/50 and the AIS-70/50 Stand

## ● Check This List First

Before you begin assembling the stand, check the list below to make sure you received all the items you should have.

- |                 |                                     |      |
|-----------------|-------------------------------------|------|
| A : Stand       | D : Coin driven screws              | : X2 |
| B : Organ       | E : M4 x 35 mm screws               | : X3 |
| C : Front Board | F : Screwdriver (triangular handle) | : X1 |

## ● Assembly

- \* Do not attempt to assemble the unit alone. At least two persons are needed to safely set up the organ.
- \* Be very careful when lifting and moving the organ, since it is quite heavy.
- \* Have a suitably sized coin ready, since it will be needed during the assembly process.
- \* Check the site where you intend to set up your organ to make sure it will provide enough support and that it is level.

## 1. Assembling the Stand/Attaching the Organ

- (1) Detach the speaker and pedal cords that have been temporarily attached to the stand's Side Board.
  - (2) Align the two (one on each side) screws on the bottom of the organ with the stand's metal retainers. Then, pull the organ forward until it is grasped by the metal retainer.
  - (3) Use the supplied screws (coin driven) to fasten the organ securely to the stand (one screw on each side).
- \* When lifting the organ, make sure to grasp it at both front and back. Avoid getting your fingers caught under it.

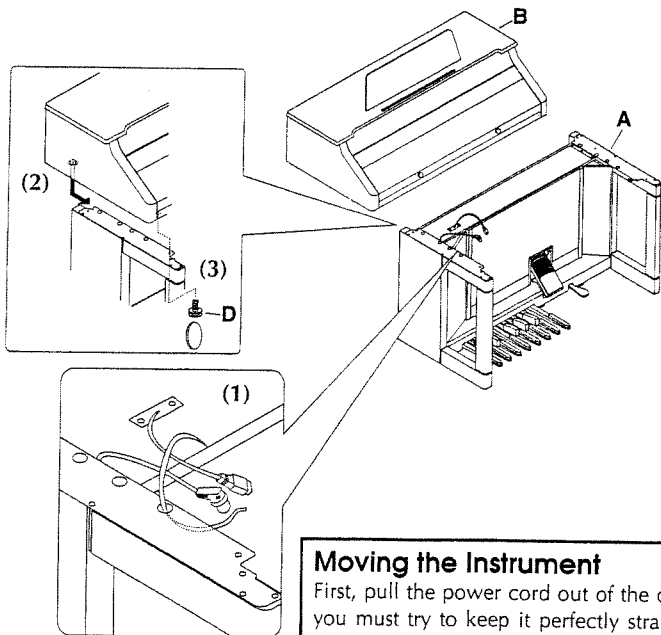

## 2. Connecting the Pedal/Speaker/Power Cords

- (4) Locate the pedal and speakers cords and connect them to their respective connectors. Next, insert the power cord into the organ's AC inlet. Then feed the power cord up over the top of the stand (speaker box) and draw it out from the rear. Its plug can then be inserted into a wall outlet. (All of the relevant connectors on the organ are at the left on its bottom surface.)

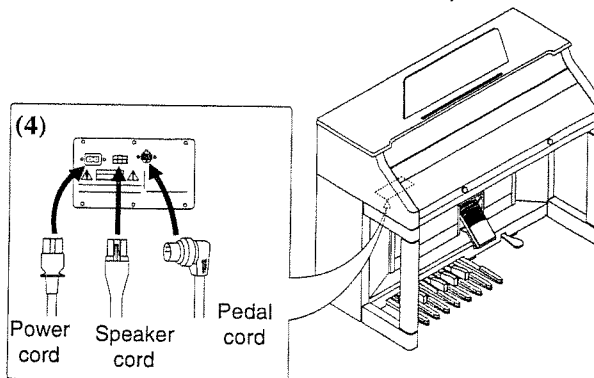

## 3. Attaching the Front Board/Positioning the Adjusters

- (5) Attach the Front Board to the organ. Attach it to its bottom surface, near the front (use the M4 x 35 mm screws).
- (6) Locate the two adjusters under the pedal board. Turn them clockwise until they make contact with the floor. If the instrument has been placed on a carpeted floor, you will need to use a little more force when lowering them to ensure firm support.

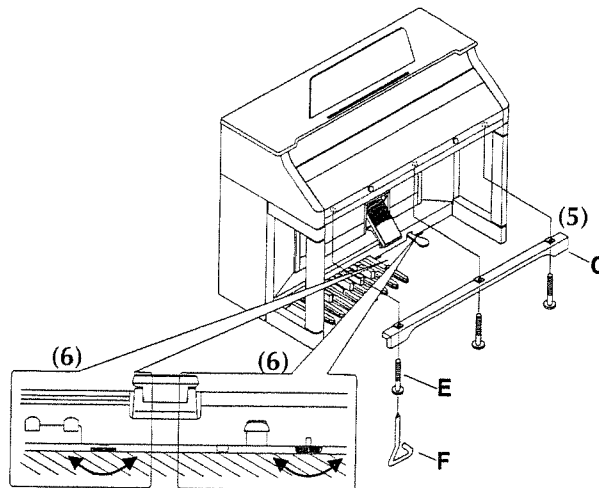

### Moving the Instrument

First, pull the power cord out of the outlet, and raise the adjusters. You can then move the instrument, but you must try to keep it perfectly straight while you do so. Also, be careful so you do not get your hands caught or drop it on your feet.

If you want to detach the organ from the stand, make sure to disconnect the pedal/speaker/power cords first.

### Disconnecting the Pedal and Speaker Cords

To disconnect the pedal cord, slide the ring in the direction shown by the arrow, then pull it out.

To disconnect the speaker cord, squeeze the bulged portion while you pull it out.

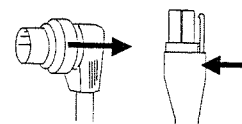

## Information

When you need repair service, call your local Roland Service Station or the authorized Roland distributor in your country as shown below.

### U. S. A.

**Roland Corporation US**  
7200 Dominion Circle  
Los Angeles, CA. 90040-3696, U. S. A.  
TEL: (213) 685-5141

### CANADA

**Roland Canada Music Ltd.**  
(Head Office)  
5480 Parkwood Way  
Richmond B. C., V6V 2M4  
CANADA  
TEL: (604) 270-6626

### Roland Canada Music Ltd.

(Montreal Office)  
9425 Transcanadienne  
Service Rd. N., St Laurent,  
Quebec H4S 1V3, CANADA  
TEL: (514) 335-2009

### Roland Canada Music Ltd.

(Toronto Office)  
346 Watline Avenue,  
Mississauga, Ontario L4Z  
1X2, CANADA  
TEL: (416) 890-6488

### AUSTRALIA

**Roland Corporation Australia Pty. Ltd.**  
38 Campbell Avenue  
Dee Why West. NSW 2099  
AUSTRALIA  
TEL: (02) 982-8266

### NEW ZEALAND

**Roland Corporation (NZ) Ltd.**  
97 Mt. Eden Road, Mt. Eden,  
Auckland 3, NEW ZEALAND  
TEL: (09) 3098-715

### UNITED KINGDOM

**Roland (U.K.) Ltd.**  
Rye Close Ancells Business  
Park Fleet, Hampshire GU13  
8UY, UNITED KINGDOM  
TEL: 0252-816181

### Roland (U.K.) Ltd., Swansea Office

Atlantic Close, Swansea  
Enterprise Park, Swansea,  
West Glamorgan SA79FJ,  
UNITED KINGDOM  
TEL: (0792) 700-139

### IRELAND

**The Dublin Service Centre Audio Maintenance Limited**  
11 Brunswick Place Dublin 2  
Republic of Ireland  
TEL: 010 353 1677322

### ITALY

**Roland Italy S. p. A.**  
Viale delle Industrie 8 20020  
ARESE MILANO ITALY  
TEL: 02-93581311

### SPAIN

**Roland Electronics de España, S. A.**  
Calle Bolivia 239 08020  
Barcelona, SPAIN  
TEL: 93-308-1000

### GERMANY

**Roland Elektronische Musikinstrumente Handelsgesellschaft mbH.**  
Oststrasse 96, 22844  
Norderstedt, GERMANY  
TEL: 040/52 60 090

### FRANCE

**Guillard Musiques Roland**  
ZAC de Rosarge 01700  
MIRIBEL FRANCE  
TEL: (7) 226-50 60

**Guillard Musiques Roland (Paris Office)**  
1923 rue Léon Geoffroy  
94400 VITRY-SUR-SEINE  
FRANCE  
TEL: (1) 4680 86 62

### BELGIUM/HOLLAND/LUXEMBOURG

**Roland Benelux N. V.**  
Houtstraat 1 B-2260 Oevel-  
Westerlo BELGIUM  
TEL: (0032) 14-575811

### DENMARK

**Roland Scandinavia A/S**  
Langebrogade 6 Box 1937  
DK-1023 Copenhagen K.  
DENMARK  
TEL: 31-95 31 11

### SWEDEN

**Roland Scandinavia A/S**  
Danvik Center 28 A, 2 tr.  
S-131 30 Nacka SWEDEN  
TEL: 08-702 00 20

### NORWAY

**Roland Scandinavia Avd. Kontor Norge**  
Lilleakerveien 2 Postboks 95  
Lilleaker N-0216 Oslo 2  
NORWAY  
TEL: 22-73 00 74

### FINLAND

**Fazer Musik Inc.**  
Länsituulentie POB 169,  
SF-02101 Espoo FINLAND  
TEL: 0-43 50 11

### SWITZERLAND

**Roland CK (Switzerland) AG**  
Gerberstrasse 5, CH-4410  
Liestal, SWITZERLAND  
TEL: 061/921 16 15

### AUSTRIA

**E. Dematte & Co.**  
Neu-Rum Siemens-Strasse 4  
A-6040 innsbruck P.O.Box  
83  
AUSTRIA  
TEL: (0512) 26 44 260

### GREECE

**V. Dimitriadis & Co. Ltd.**  
20, Alexandras Avn., GR  
10682 Athens, GREECE  
TEL: 01-8232415

### PORTUGAL

**Casa Caius Instrumentos Musicais Lda.**  
Rua de Santa Catarina 131  
4000 Porto, PORTUGAL  
TEL: 02-38 44 56

### HUNGARY

**Intermusica Ltd.**  
Warehouse Area 'DEPO'  
Torokbalint, Budapest  
HUNGARY  
TEL: (1) 1868905

### ISRAEL

**D.J.A. International Ltd.**  
11 Bar Gyiara St., Tel Aviv  
ISRAEL  
TEL: 972-3-525-3834

### CYPRUS

**Radex Sound Equipment Ltd.**  
17 Diagorou St., P.O.Box  
2046, Nicosia CYPRUS  
TEL: 453426, 466423

### U.A.E

**Zak Electronics & Musical Instruments Co.**  
P.O. Box 8050  
DUBAI, U.A.E  
TEL: 695774

### SAUDI ARABIA

**Omar Badoghais Trading Corp.**  
P.O. Box 5980  
Jeddah, SAUDI ARABIA  
TEL: 966-02-6607038

### KUWAIT

**Easa Husain Al-Yousifi**  
P.O. Box 126 Safat 13002  
KUWAIT  
TEL: 965-5719499

### LEBANON

**A. Chahine & Fils**  
P.O. Box 16-5857  
Beirut, LEBANON  
TEL: 335799

### TURKEY

**Barkat Sanayi ve Ticaret**  
Siraselviler Cad. 86/6 Taksim  
Istanbul, TURKEY  
TEL: 212-2499324

### EGYPT

**Al Fanny Trading Office**  
9, Ebn Hagar Ai Askalany  
Street, Ard El Golf,  
Heliopolis, Cairo, 11341  
EGYPT  
TEL: 2917803-665918

### QATAR

**Badie Studio & Stores**  
P.O.Box 62,  
DOHA Qatar  
TEL: 974 423554

### BAHRAIN

**Moon Stores**  
Bad Al Bahrain Road,  
P.O.Box 20077  
State of Bahrain  
TEL: (0973) 211 005

### BRAZIL

**Roland Brasil Ltda.**  
R. Coronel Octaviano da  
Silveira 203  
05522-010 Sao Paulo  
BRAZIL  
TEL: (11) 843-9377

### MEXICO

**Casa Veerkamp, s.a. de c.v.**  
Mesones No. 21 Col. Centro  
MEXICO D.F. 06080  
TEL: (5) 709-3716

**La Casa Wagner de Guadalajara s.a. de c.v.**  
Av. Corona No. 202 S.J.  
C.P.44100 Guadalajara,  
Jalisco MEXICO  
TEL: (36) 13-1414

### VENEZUELA

**Musicland Digital C.A.**  
Av. Francisco De Miranda,  
Centro Parque Cristal, Nivel  
C2 Local 20 Caracas  
VENEZUELA  
TEL: (2)2844497

### PANAMA

**Productos Superiores, S.A.**  
Apartado 655 - Panama 1  
REP. DE PANAMA  
TEL: 26-3322

### ARGENTINA

**Instrumentos Musicales S.A.**  
Florida 638  
(1005) Buenos Aires  
ARGENTINA  
TEL: (1)394-4029

### HONG KONG

**Tom Lee Music Co., Ltd. Service Division**  
22-32 Pun Shan Street, Tsuen  
Wan, New Territories,  
HONG KONG  
TEL: 415-0911

### KOREA

**Cosmos Corporation Service Station**  
261 2nd Floor Nak-Won  
Arcade Jong-Ro ku, Seoul,  
KOREA  
TEL: (02) 742 8844

### SINGAPORE

**Swee Lee Company**  
BLOCK 231,  
Bain Street #03-23  
Bras Basah Complex,  
Singapore 0718  
TEL: 3367886

### PHILIPPINES

**G.A. Yupangco & Co. Inc.**  
339 Gil J. Puyat Avenue  
Makati, Metro Manila 1200,  
PHILIPPINES  
TEL: 02 (817) 0013

### THAILAND

**Theera Music Co., Ltd.**  
330 Verng Nakorn Kasem,  
Soi 2, Bangkok 10100,  
THAILAND  
TEL: 2248821

### MALAYSIA

**Bentley Music SDN BHD**  
No.142, Jalan Bukit Bintang  
55100 Kuala Lumpur,  
MALAYSIA  
TEL: (03) 2443333

### INDONESIA

**PT Citrarama Belantika**  
JL Alaydrus 84 B  
Jakarta 10130  
INDONESIA  
TEL: (021) 3802638,  
3802639

### TAIWAN

**Siruba Enterprise (Taiwan) Co., LTD.**  
Room. 5, 9fl. No. 112 Chung  
Shan N.Road Sec.2 Taipei,  
TAIWAN, R.O.C.  
TEL: (02) 571-5860

### SOUTH AFRICA

**That Other Music Shop (PTY) Ltd.**  
11 Melle Street (Cnr Melle  
and Juta Street)  
Braamfontein 2001  
Republic of South Africa  
TEL: 27 11 403-4105

### Paul Bothner (PTY) Ltd.

17 Werdmuller Centre  
Claremont 7700  
Republic of South Africa  
TEL: 021-64-4030





For Germany

### Bescheinigung des Herstellers/Importeurs

Hiermit wird bescheinigt, daß der/die/das  
**Roland Organ AT-70 / 50**

(Gerät, Typ, Bezeichnung)

in Übereinstimmung mit den Bestimmungen der BMPT-AmtsblVfg 243/1991 funk-entstört ist. Der vorschriftsmäßige Betrieb mancher Geräte (z. B. Meßsender) kann allerdings gewissen Einschränkungen unterliegen. Beachten Sie deshalb die Hinweise in der Bedienungsanleitung.

Dem Zentralamt für Zulassungen im Fernmeldewesen wurde das Inverkehrbringen dieses Gerätes angezeigt und die Berechtigung zur Überprüfung der Serie auf die Einhaltung der Bestimmungen eingeräumt.

Roland Corporation

4-16 Dojimahama 1-Chome Kita-ku Osaka 530 Japan

(Name und Anschrift des Herstellers/Importeurs)

For the USA

### FEDERAL COMMUNICATIONS COMMISSION RADIO FREQUENCY INTERFERENCE STATEMENT

This equipment has been tested and found to comply with the limits for a Class B digital device, pursuant to Part 15 of the FCC Rules. These limits are designed to provide reasonable protection against harmful interference in a residential installation. This equipment generates, uses, and can radiate radio frequency energy and, if not installed and used in accordance with the instructions, may cause harmful interference to radio communications. However, there is no guarantee that interference will not occur in a particular installation. If this equipment does cause harmful interference to radio or television reception, which can be determined by turning the equipment off and on, the user is encouraged to try to correct the interference by one or more of the following measures:

- Reorient or relocate the receiving antenna.
- Increase the separation between the equipment and receiver.
- Connect the equipment into an outlet on a circuit different from that to which the receiver is connected.
- Consult the dealer or an experienced radio/TV technician for help.

Unauthorized changes or modification to this system can void the users authority to operate this equipment.  
This equipment requires shielded interface cables in order to meet FCC class B Limit.

For Canada

#### CLASS B

#### NOTICE

This digital apparatus does not exceed the Class B limits for radio noise emissions set out in the Radio Interference Regulations of the Canadian Department of Communications.

#### CLASSE B

#### AVIS

Cet appareil numérique ne dépasse pas les limites de la classe B au niveau des émissions de bruits radioélectriques fixés dans le Règlement des signaux parasites par le ministère canadien des Communications.

 Roland®

10676

UPC

10676



1098:

AT70/50