

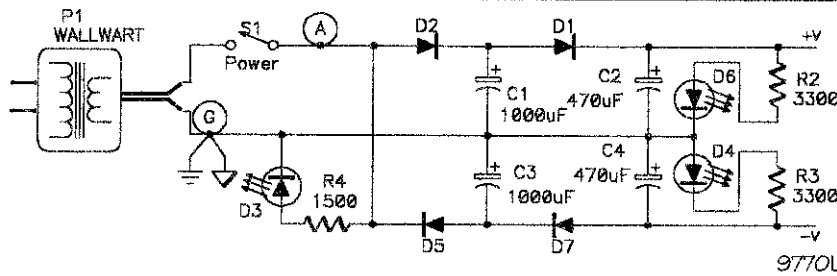

Universal Power Supply

Model 9770 Assembly Instructions



9770U Unregulated

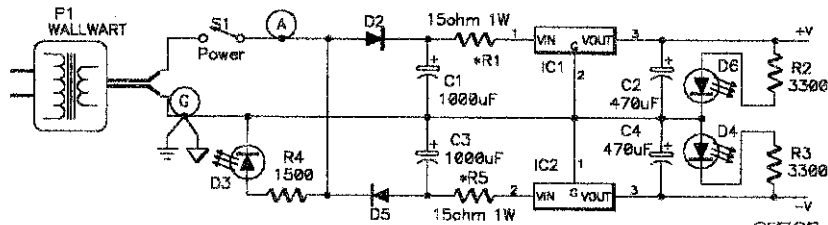

9770R-12 or 9770R-15
Regulated - *R1 and *R5
not used on 9770R-15

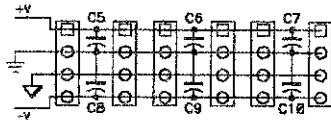

The 9700 Universal Power Supply is available in three configurations: As an unregulated supply with nominal +/- 18V outputs or as +/- 12V or +/- 15V regulated versions. LEDs indicate status of AC to the supply and positive and negative supply rails.

The 9700/U is the recommended power supply for 9700 synthesizer systems that do not include a midi2cv8 module.

The 9770R-12 and 9770R-15 regulated supplies are suitable replacements for the much bulkier and more difficult to build BPS-12 and BPS-15 supplies previously recommended for use with PAiA equipment requiring bipolar regulated supplies.

The Power Wing accessories allow the 9770 supplies to be mounted in a FracRak case without taking up a module space.

9770 Universal Power Supply Parts Lists

Quan	Description	Designation
6	0.01uF Ceramic Disk Capacitors	C5,C6,C7, C8,C9,C10
2	1N4001 Power Diodes	D2,D5
3	Red LED	D3,D4,D6
2	1000uF 25V Electrolytic Caps	C1,C3
2	470uF 25V Electrolytic Caps	C2,C4
2	3300 ohm 1/4 W. Resistor	R2,R3
1	1500 ohm 1/4 W. Resistor	R4
1	14VAC Wall Mount Transformer	P1
1	6" length #22 Stranded Insulated Wire	
1	9770pc Circuit Board	
9770U adds these parts:		
2	1N4001 Power Diodes	D1,D7
9770R-12 adds these parts:		
1	7812 +12V Voltage regulator	IC1
1	7912 -12V Voltage regulator	IC2
2	15 ohm 1W resistors	R1,R5
9770R-15 adds these parts		
1	7815 +15V Voltage regulator	IC1
1	7915 -15V Voltage regulator	IC2
1	5" Length Bare Wire	

THE CIRCUIT BOARD

The Universal Power Supply is built on a single-sided, tin-lead plated, solder masked circuit board. No cleaning or special preparation is necessary before assembly.

SOLDERING

Select a soldering iron with a small tip and a power rating not more than 35 watts. Soldering guns are completely unacceptable for assembling solid state equipment because the large magnetic field they generate can damage components.

Use only rosin core solder (acid core solder is for plumbing, not electronics work). A proper solder joint has just enough solder to cover the soldering pad and about 1/16 inch of lead passing through it. There are two improper connections to beware of: Using too little solder will sometimes result in a connection which appears to be soldered when actually there is a layer of flux insulating the component lead from the solder bead. This situation can be cured by reheating the joint and applying more solder. If too much solder is used on a joint there is the danger that a conducting bridge of excess solder will flow between adjacent circuit board conductors forming a short circuit. Accidental bridges can be cleaned off by holding the board upside down and flowing the excess solder off onto a clean, hot soldering iron.

Mount the circuit board components by passing their leads through the holes provided for them on the silk-screen legended side of the board and solder on the copper side. Clip off any excess component lead flush with the solder joint. Use care when mounting all components. Never force a component into place. Use the excess lead clipped from one of the resistors for the wire jumper shown in the component placement illustration above.

Check off each component as it is mounted. Resistors and disk capacitors are not polarized and may be mounted with either lead in either of the holes in the circuit board. The electrolytic capacitors, LEDs, diodes and ICs are polarized and must be oriented as shown in the illustrations.

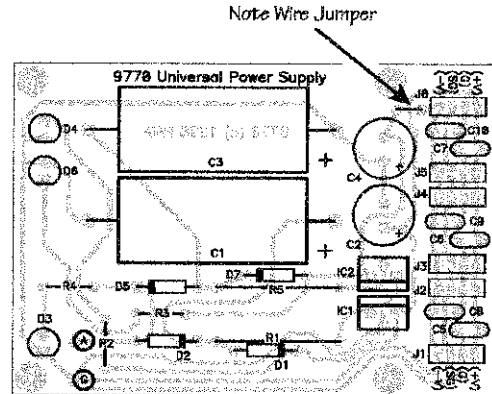

Components are mounted on the board in the locations shown. Phantom traces show connections between parts.

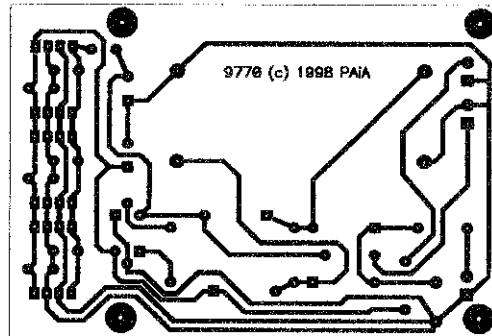

This foil pattern art will be useful if you need to check for solder bridges.

These parts are used in all versions of the 9770:

- 1/4W Resistors: color code- A B C
 R2 3300 ohm orange-orange-red
 R3 3300 ohm orange-orange-red
 R4 1500 ohm brown-green-red

- 0.01 uF Ceramic Disk Capacitors:
 C5 C6 C7 C8 C9 C10

- Electrolytic Capacitors:
 C1 C3 1000uF 25V Axial Lead
 C2 C4 470uF 25V Radial Lead

- 1N400x Power Diodes:
 D2 D5 (1N4001 - 1N4005 may be supplied)

- Red LEDs:
 D3 D4 D6 Mount as shown
 Install jumper as on facing page.

These parts are unique to the 9770U:

- 1N400x Power Diodes:
 D1 D7 (1N4001 - 1N4005 may be supplied)

These parts are unique to the 9770R-12:

- Voltage Regulators:
 IC1 7812 +12V **IMPORTANT** - Tabs of adjacent
 IC2 7912 -12V voltage regulators must not
touch one another

- 1W Power resistors:
 R1 R5 15 ohm brown-green-black

These parts are unique to the 9770R-15:

- Voltage Regulators:
 IC1 7815 +15V **IMPORTANT** - Tabs of adjacent
 IC2 7915 -15V voltage regulators must not
touch one another

- Using 2-1/2" lengths of the bare wire supplied install
jumpers in the circuit board locations designated
R1 and R5. These resistors are not used in this
version of the power supply.

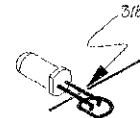
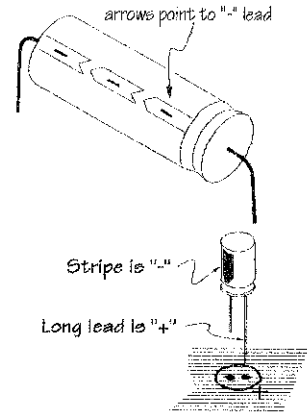

Space LEDs 3/8" from board, bend to engage panel holes. Note orienting flat on case and circuit board graphics.

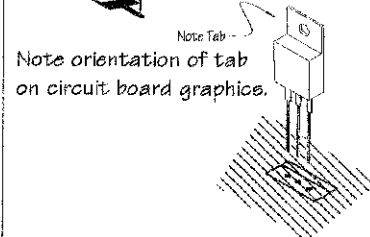
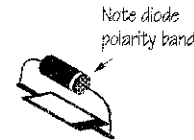

Power Wing Installation

Before installing the 9770 circuit board push the grommet into place as shown. If there is a connector on the end of the transformer power cord clip it off and pass the end of the cord through the grommet. Knot the cord 7" from the end for strain relief and separate the two wires. Strip 1/4" of insulation from the ends and solder either of the wires to circuit board point "G".

Strip 1/4" of insulation from each end of the 6" wire supplied and solder one end to circuit board point "A".

Install the assembled 9770 circuit board in the FracRak end panel using the (4) #4x1/2" Machine screws, (4) 3/16" spacers and (4) nuts as shown in the illustration. Align the LEDs so they engage the holes in end panel as shown.

Assemble the module mounting bars and Wing Power ear as shown in the illustration and the assembly sheet supplied with the FracRak. Remove all nuts and washers from the switch and secure it only with the knurled nut supplied. Solder the free wire from the transformer to the bottom lug of the switch and the free wire from circuit board point "A" to the middle lug.

POWER DISTRIBUTION

The power distribution locations on the circuit board have both Power Ground (G) and Signal Ground (SG) connections. When powering devices that do not have similar provisions, run two wires from the G and SG points on the 9770 circuit board to the single ground point on the device. If desired, 0.1 center IDC connectors can be soldered to the 9770 board and used for power distribution.

