



MACKIE HOOK-UP GUIDE



HDR24/96 DIGITAL RECORDER



**OUR [IN]FAMOUS PRODUCT
HOOKUPS IN BYTE-SIZED MORSELS**

Copyright © 2002 Mackie Designs Inc. All Rights Reserved.

PRINTING NOTE: These pages were built 21cm wide (8.26in) by 27.94cm (11in) tall to accommodate the printers of both our North American users and our users around the globe. This PDF will print at 100% on both “Letter” sized and “A4” sized paper (with room in the left margin for hole punching).

Hello and welcome to one of many downloadable web editions of Mackie’s Product Hook-Up Guide. Since 1992, we’ve been including these helpful “connection maps” in our ***In Your Face*** product guides, and we’ve been urged to continue doing so because they’re so gosh-darned helpful. Now, we’ve split our hook-ups into product families, and made them available to you over this new-fangled “Internet” thingy that everyone is talking about these days.

There will be documents that cover hooking up our compact VLZ® PRO Series, Analog 8•Bus Series consoles, CFX Series effects mixers, DFX Series compact effects mixers, the D8B digital console, the HDR24/96 hard disk recorder, PPM Series powered mixers, the FR Series amplifiers, SR Series front-of-house mixers, and our Active loudspeakers.

Inside you’ll find lots of useful information – most likely your questions will be answered here. We realize that there’s no possible way to cover every single question or application in so few pages because new ways to use Mackie products are invented every day. You may come up with some ideas on how to do what you want by looking at the various diagrams we’ve included here.

Keep in mind that a good half of the battle in hooking up our products is having the proper connections. Check the cables ’n’ plugs that you already have with the diagrams on the next page. We know it may look boring, but one of these drawings could save your life. Well, maybe not your life, but probably a lot of weeping and sorrow. And don’t forget to check out the tech tips/FAQs document also available for download, as well as on the web at www.mackie.com/record/techsupport/

If you don’t find the answers you’re after, then why not give our mighty Tech Support gang a call? These folks have tons of experience in the real world, and they’ve got lots of equipment and mixers at their beck and call. They’re aching to share their knowledge with you. (And calling them would be a very humanitarian thing to do – they’re located in the dank sub-basement of our building and they rarely get visitors. Your call just may be the one that keeps their spirits alive.)

Call Mackie Tech Support toll-free (in the U.S.) at 800-258-6883 (Monday through Friday, 7 AM to 5 PM Pacific Time) with any Mackie product-question you can conjure. Put them through the wringer! We encourage it.

Incidentally, the Mackie Product Hook-Up Guide (Web Editions) were put together from within the confines of the Mackie Digital Mosh Pit – located on the second floor near the Area Of Refuge – by the well-meaning, super-preening Mackie Macintosh Department. We used Adobe InDesign®, Illustrator®, Photoshop®, and Acrobat® on a number of suped-up big daddy Macs.

Oh yeah: Copyright © 2002 Mackie Designs Inc. All Rights Reserved.

The following are trademarks or registered trademarks of Mackie Designs Inc.: “MACKIE.”, the “Running Man” figure, VLZ, XDR, D8B, HUI, CFX Series, FR Series, and HR Series.

TS Plug (mono)

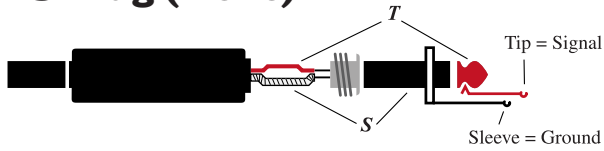

Standard mono/unbalanced phone plug used for most mixer connections.

TRS Plug (stereo)

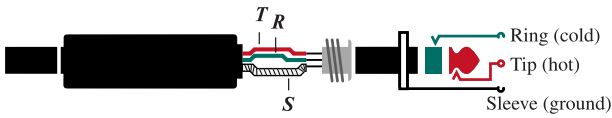

Standard stereo/balanced phone plug used for balanced connections on Mackie mixers.

Balanced XLR

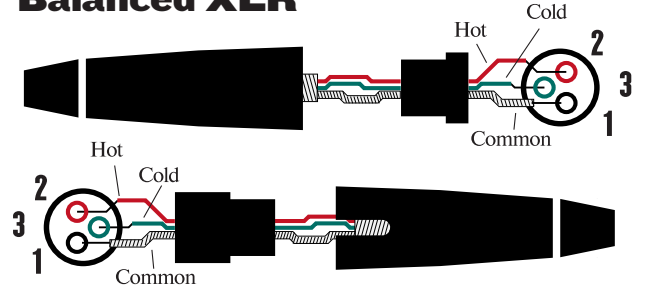

Standard XLR microphone connector to be used with mic-level.

RCA/Phono Plug

Tape deck connections on most Mackie mixers.

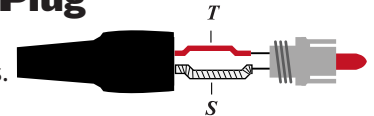

Insert "Y" Cable

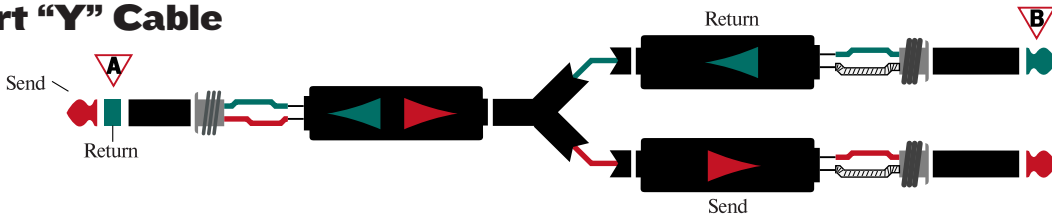

The "Y" Cable is used for connecting serial effects devices, such as graphic equalizers or compressors, to a Mackie mixer's Channel or Bus insert jacks. On one end is a standard Tip-Ring-Sleeve "stereo" plug. Its tip and ring are wired to separate mono Tip-Sleeve plugs. Note that the RING of the TRS plug (A) is actually wired to the TIP of one of the mono TS plugs (B). If you insert a TS (mono) 1/4" plug only partially (to the first click) into an insert jack, the plug will not activate the jack switch and will not break the insert connection in the circuit (thereby allowing the channel signal to continue on its merry way through

the mixer). See (C) in "Insert Points" below.

Partial insertion allows you to tap out of the channel or bus circuit at that point in the circuit without interrupting normal operation.

If you push the 1/4" TS plug in to the second click, you will open the jack switch and create a direct out, which does interrupt the signal in that channel or bus circuit. See (D) in "Insert Points" above. Note: Do not overload or short-circuit the signal you are tapping from the mixer. That will affect the internal signal of the mixer.

Insert Points

TS Plug (mono)



Direct out with no signal interruption to master. Insert only to first "click."

TS Plug (mono)



Direct out with signal interruption to master. Insert all the way in to the second "click."

TRS Plug (stereo)



For use as an effects loop. (TIP = SEND to effects RING = RETURN from effects)

Attention !



You may notice these effects unit hookups (Figure A) throughout this applications guide. These hookups utilize the Insert "Y" Cable (explained above).

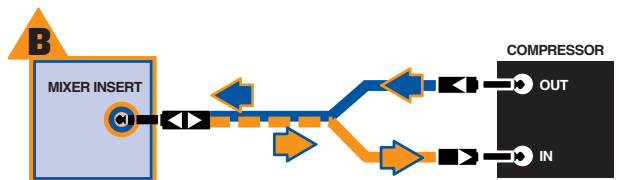
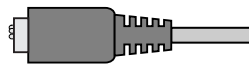

Figure B is a closeup of Figure A. The two colors represent the input and output traveling the length of the "Y" cable. The dotted line represents the two signals travelling alongside one another.

Welcome to the wonderful world of digital connectors. Sheesh! It was so much easier when there were only a couple of kinds of analog plugs. And what's worse, two of the digital connectors (AES/EBU & S/PDIF) look like an analog jacks but emphatically aren't. Plus one of them looks like an analog connector (SMPTE) and is basically the same as the corresponding analog plug. Go figure.

Even if you're a whiz at soldering, we don't recommend trying to cobble up any of the digital plug and connectors shown on this page. These cables transmit far higher frequencies than analog audio and require arcane shielding and pin polarities. If you're making digital connections to our HDR24/96, or Digital 8•Bus, we recommend biting the bullet and buying pre-made versions from your friendly Mackie dealer. Purchasing good quality cables now can prevent a lot of troubleshooting down the line.

MIDI (Plug)



MIDI (Jack)



Used for sending or receiving MIDI Time Code (MTC) or MIDI Machine Control (MMC) between all MDS products. Typical use of this jack would be an MDR24/96 receiving MMC messages coming from the D8B, so that you can use the on-board PLAY, STOP, REW, and FF buttons as a transport.

MIDI "Breakout" Connector

Instead of two separate MIDI ports, Mackie uses a single 9-pin MIDI connector that carries both MIDI In and MIDI Out signals simultaneously. We conveniently include one of our adaptors with every digital recorder and mixer we sell.

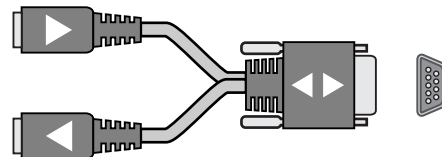

AES/EBU (XLR-style)



For professional, balanced stereo digital I/O to/from the Digital 8•Bus' Digital I/O section. Resist the temptation to use a standard audio-grade XLR cable. AES/EBU digital audio data is transmitted at far higher frequencies and requires a special cable. Use the AES/EBU output to connect to any number of stereo mastering devices or DVD/CD/DAT recorders.

ADAT™ Optical Connector



Used for 8-channel digital connections via optical cable to and from our DIO•8, OPT•8, and OPT•24 I/O cards.

RJ45 Connector

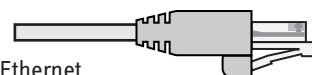

Used for connecting the HDR24/96 or Digital 8•Bus to Ethernet networks or computers. The Remote cable, (used to connect HDR24/96 recorders to the Remote 24 and Remote 48) also uses a RJ45 connector.

S/PDIF (RCA-type connector)

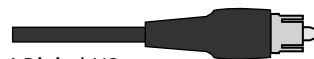

For unbalanced stereo digital I/O to/from the Digital 8•Bus' Digital I/O. Resist the temptation to use a standard audio-grade RCA cable. S/PDIF digital data is transmitted at far higher frequencies and requires a special cable. Use the S/PDIF jack to connect the Digital 8•Bus to any number of stereo digital recorders, CD burners, or PCI sound cards.

Word Clock (BNC connector)



Used to sync the sampling clocks of all Mackie's digital products. This connector must be used to synchronize (or align) the sampling clocks of multiple digital devices, which allows digital audio data to pass from one device to another. All of our digital recorders and consoles can act as a master clock source, or as a slave to a common word clock source.

SMPTE (1/4" TRS)



Standing for Society of Motion Picture and Television Engineers (SMPTE), this is used to either send out or receive longitudinal time code (LTC) as a positional reference of your playback. SMPTE is used with standard analog 1/4" cables, even though its application is common to digital and analog devices. However, we still recommend that you buy an extremely high quality, pre-made version for sync connections, even if you're an old hand at wiring analog audio TRS's.

25-pin D-Sub Connectors in Three Flavors:

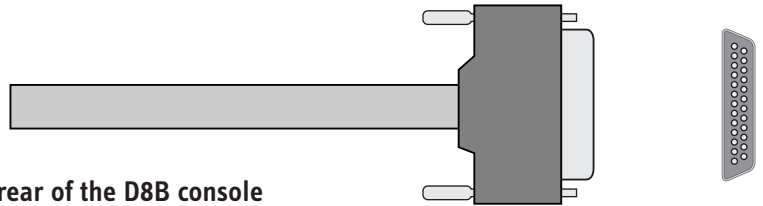

1. Analog – Found on both AIO•8 Cards and rear of the D8B console

You'll find two of these funny looking things on any Mackie AIO•8 Analog 8-channel I/O card, as well as one permanently installed on the rear of the Digital 8•Bus Mixer (labeled "Sub/Surround Out") Don't worry – these are simply compact ways of sending and receiving 8 channels of balanced line level signals.

Use the connectors on the AIO•8 cards to connect any analog tape machine, mixing console, etc. to any MDS Product. Use the Sub/Surround Out connector for sub bussing or monitoring a completed LCRS, Quad, 5.1 or 7.1-surround mix. For all purposes, you need to use the multi-channel analog "snake" cables that can be purchased from your friendly Mackie dealer.

2. AES/EBU – Found on PDI•8 Card only

You'll find one of these funny looking things on all Mackie PDI•8 I/O cards. Even though it looks identical to the connector found on the AIO•8 cards, it carries digital audio signals instead of analog. Because each pair of AES/EBU signals are multiplexed and sent through a single wire, you only need one 25-pin connector to send AND receive eight channels of AES/EBU. You need to use this connector with a special AES/EBU "snake" cable that splits out to (4) male and (4) female XLR-style connectors on the other end. Ask your MDS dealer for more information about obtaining this cable.

3. Tascam Digital Interface (T/DIF) – Found on DIO•8 Card only

Every DIO•8 card has a 25-pin T/DIF connector on it for connecting specifically to Tascam-branded recording and mixing products. Like the AES/EBU connector, the T/DIF connector can both send and receive 8 channels of digital audio. However, instead of using a standard 25-pin D-Sub "snake" cable, you need to use a special "T/DIF" cable, with a 25-pin D-Sub connector at both ends, designed specifically for this purpose.

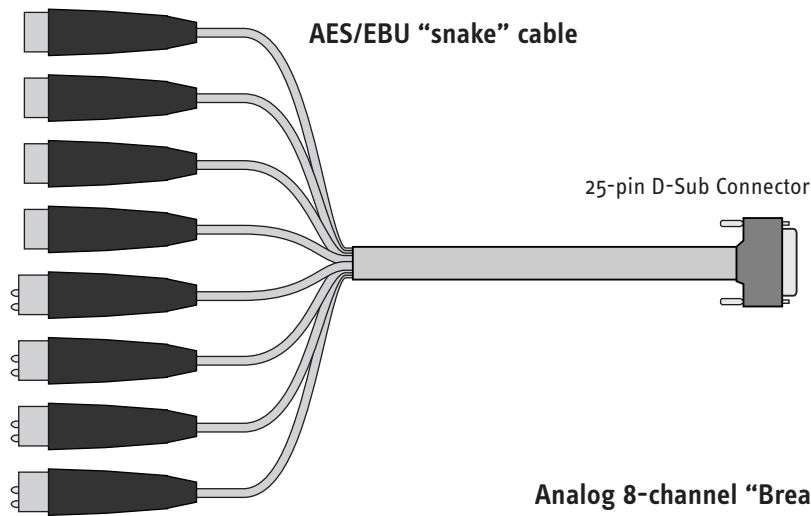

AES/EBU Connectors

Analog 8-channel "Breakout" Connector

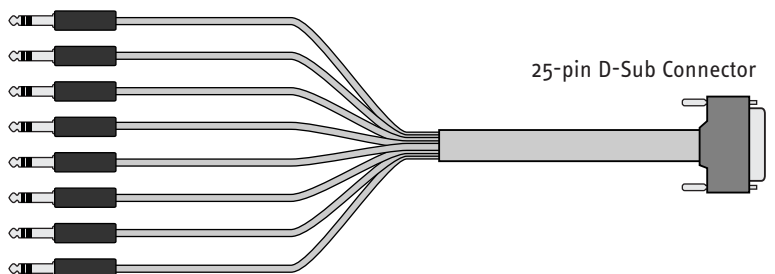

1/4" TRS Connectors



HDR 24/96

ANALOG RECORDING

SET IT UP, AND GO!

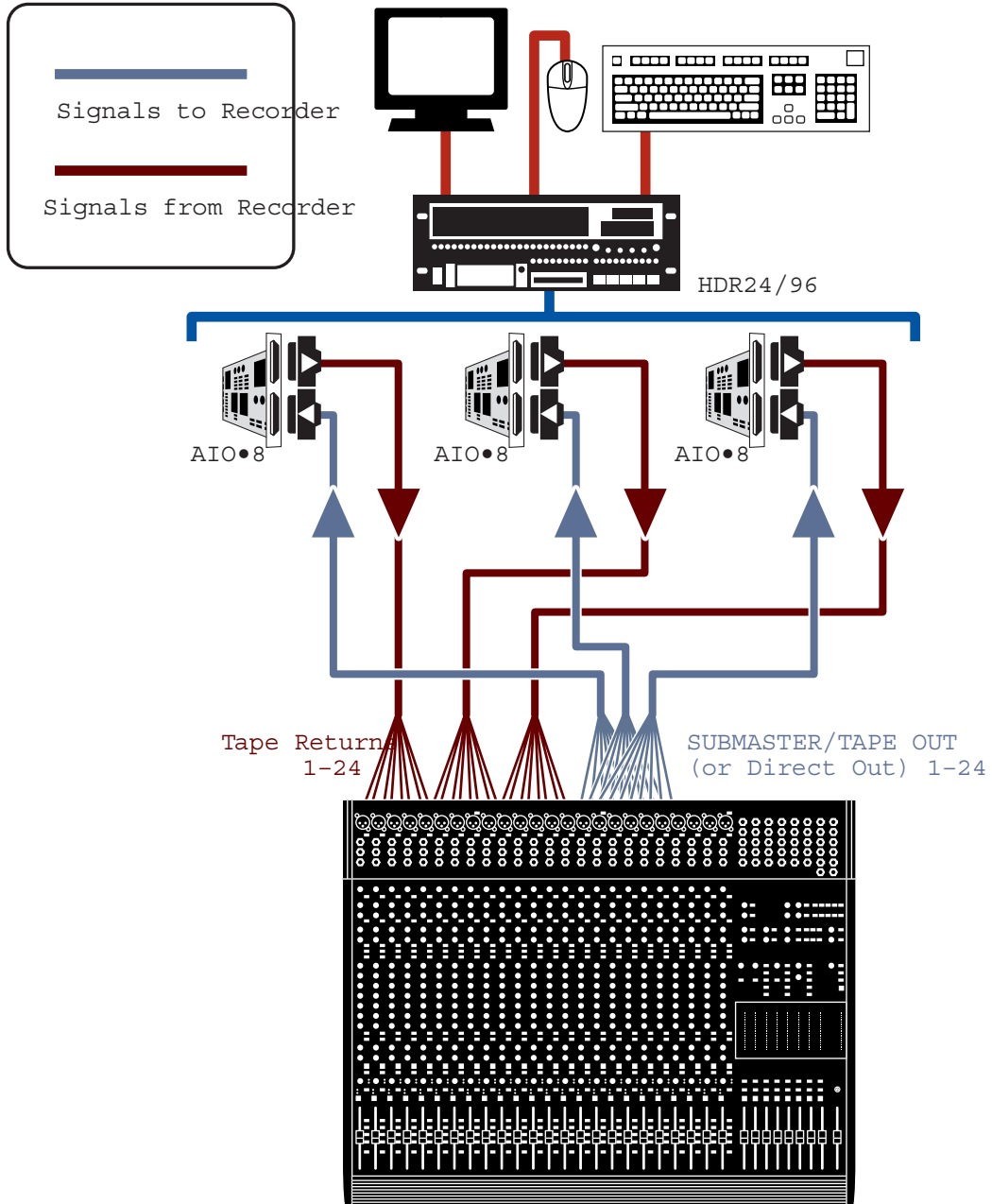



HDR 24/96

DIGITAL RECORDING

SET UP, AND GO!

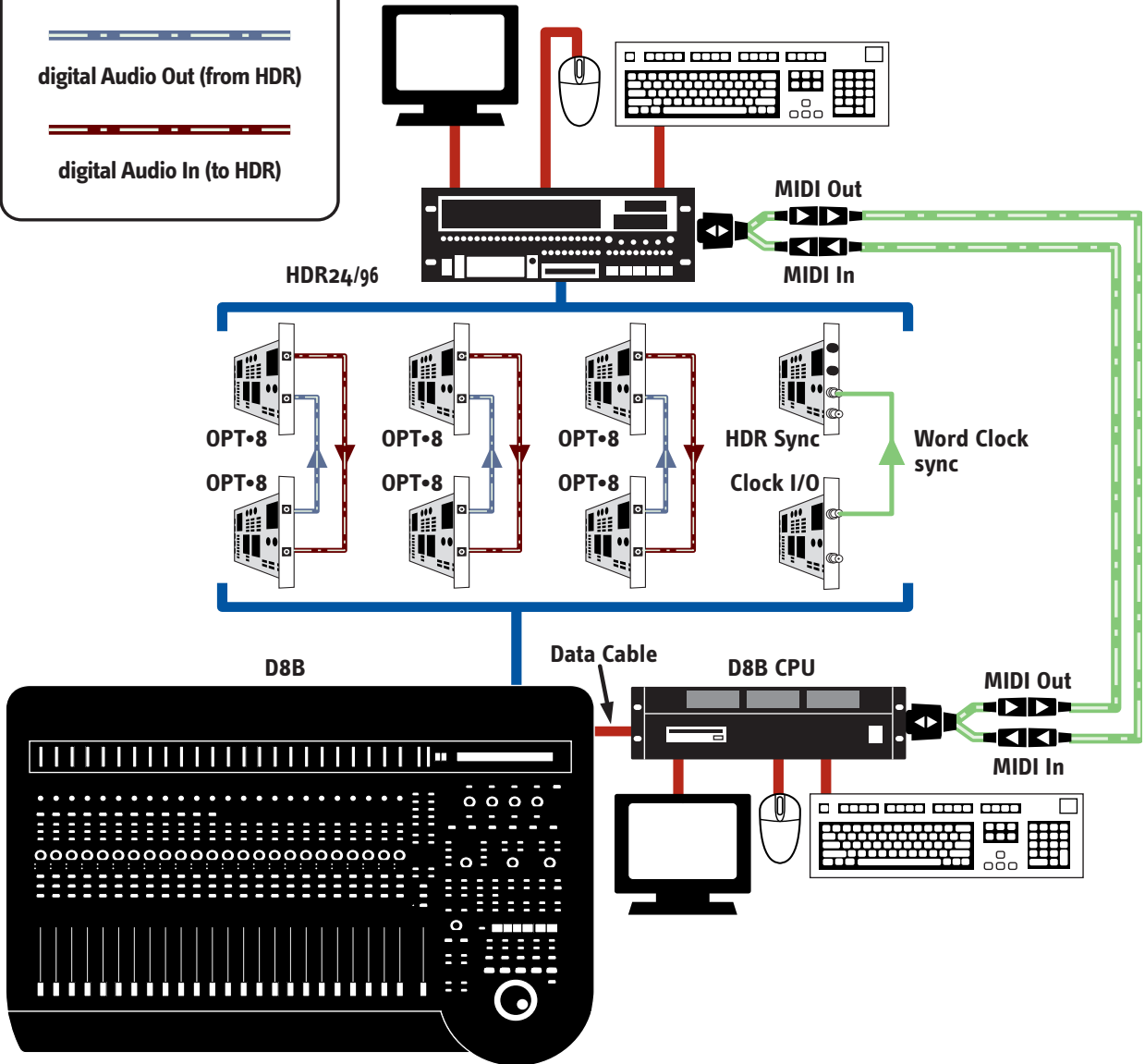
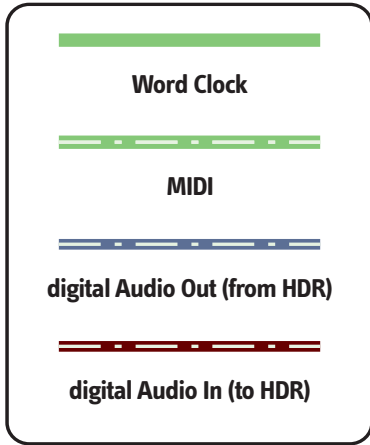



DUAL HDR 24/96

WITH REMOTE 48 AND DUAL D8B

SET IT UP, AND GO!

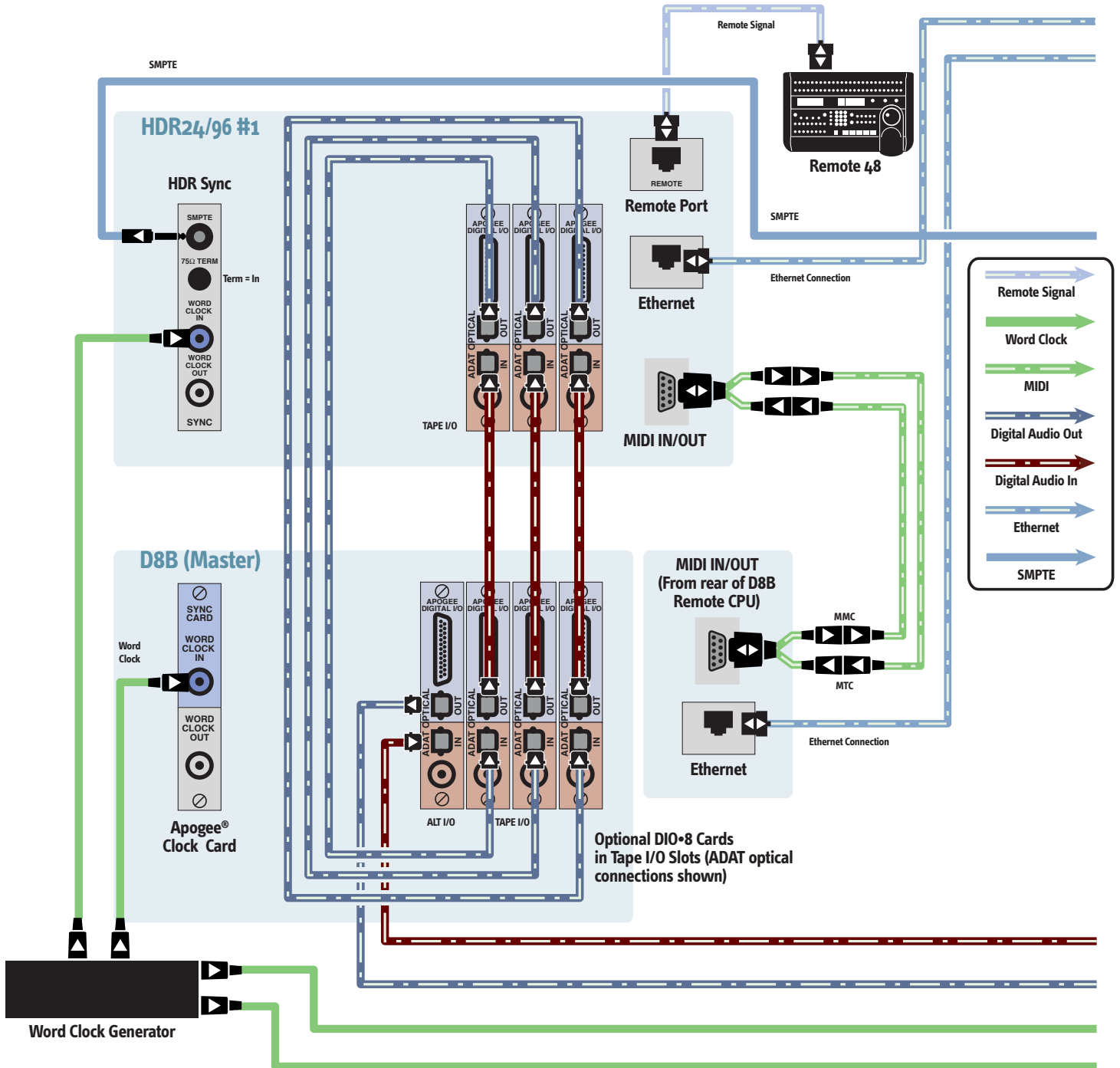

Optional DIO*8 Cards in Tape I/O Slots (ADAT optical connections shown)

Continued on next page

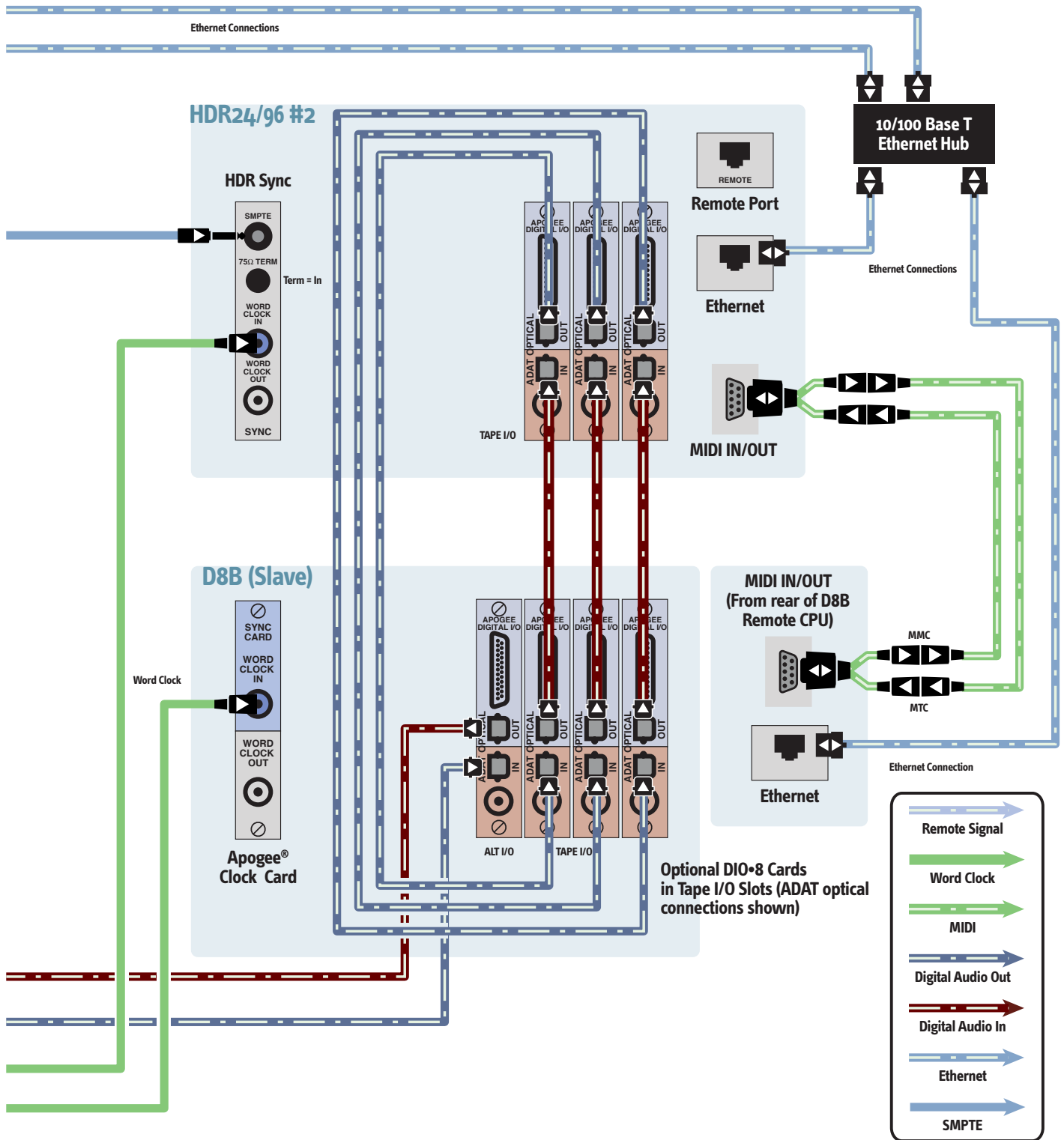

Continued from
previous page