

[®]
MACKIE

C300/C300i
TWO-WAY PORTABLE
SOUND REINFORCEMENT
SPEAKER USER'S MANUAL
AND WARRANTY REGISTRATION

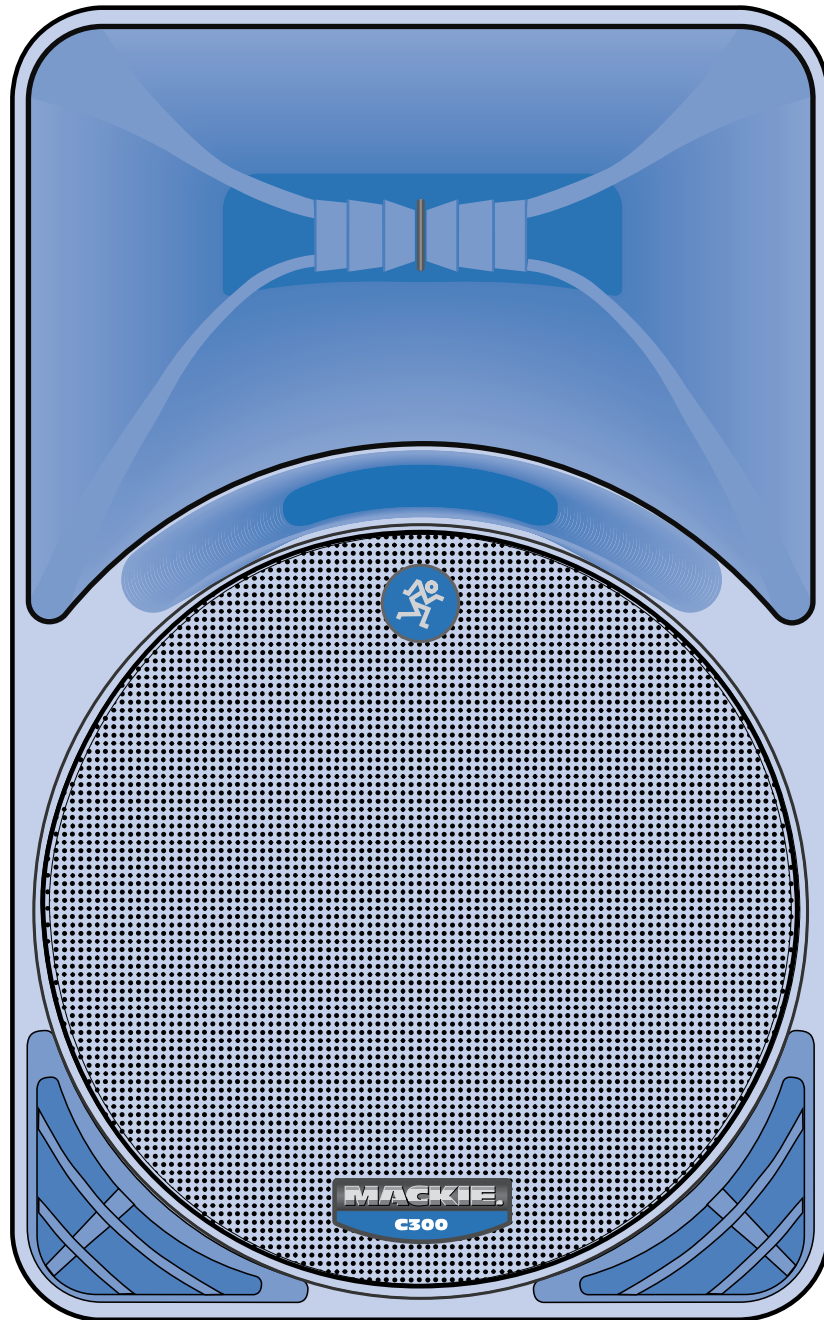

SAFETY INSTRUCTIONS

1. **Read Instructions** — All the safety and operation instructions should be read before this Mackie product is operated.
2. **Retain Instructions** — The safety and operating instructions should be kept for future reference.
3. **Heed Warnings** — All warnings on this Mackie product and in these operating instructions should be followed.
4. **Follow Instructions** — All operating and other instructions should be followed.
5. **Water and Moisture** — This Mackie product should not be used near water — for example, near a bathtub, washbowl, kitchen sink, laundry tub, in a wet basement, near a swimming pool, swamp or salivating St. Bernard dog, etc.
6. **Heat** — This Mackie product should be situated away from heat sources such as radiators, or other devices which produce heat.
7. **Object and Liquid Entry** — Care should be taken so that objects do not fall on and liquids are not spilled into this Mackie product.
8. **Damage Requiring Service** — This Mackie product should be serviced only by qualified service personnel when:

- A. Objects have fallen, or liquid has spilled into this Mackie product; or
- B. This Mackie product has been exposed to rain; or
- C. This Mackie product does not appear to operate normally or exhibits a marked change in performance; or
- D. This Mackie product has been dropped, or its chassis damaged.

9. **Servicing** — The user should not attempt to service this Mackie product beyond those means described in this operating manual. All other servicing should be referred to the Mackie Service Department.



10. **Exposure to extremely high noise levels** may cause permanent hearing loss. Individuals vary considerably in susceptibility to noise-induced hearing loss, but nearly everyone will lose some hearing if exposed to sufficiently intense noise for a period of time. The U.S. Government's Occupational Safety and Health Administration (OSHA) has specified the permissible noise level exposures shown in the following chart.

According to OSHA, any exposure in excess of these permissible limits could result in some hearing loss. To ensure against potentially dangerous exposure to high sound pressure levels, it is recommended that all persons exposed to equipment capable of producing high sound pressure levels use hearing protectors while the equipment is in operation. Ear plugs or protectors in the ear canals or over the ears must be worn when operating the equipment in order to prevent a permanent hearing loss if exposure is in excess of the limits set forth here.

Duration Per Day In Hours	Sound Level dBA, Slow Response	Typical Example
8	90	Duo in small club
6	92	
4	95	Subway Train
3	97	
2	100	Very loud classical music
1.5	102	
1	105	Patrice screaming at Ron about deadlines
0.5	110	
0.25 or less	115	Loudest parts at a rock concert

CONTENTS

INTRODUCTION	3
HOOKUP DIAGRAMS	4
Quick Start	4
PLACEMENT	6
RIGGING	7
SERVICE INFO	8
Warranty Service	8
Troubleshooting	8
Repair	8

CARE AND MAINTENANCE	9
SPECIFICATIONS	10
C300 LIMITED WARRANTY	11
PRODUCT REGISTRATION CARD	Attached to back cover



Don't forget to visit our website at www.mackie.com
for more information about these and other Mackie products.

INTRODUCTION

Thank you for choosing Mackie Designs' sound reinforcement speakers.

The C300 has a Speakon® input, and the C300i has a 1/4 inch phone jack. Apart from this difference, all details in this manual apply to both models.

The C300 is a portable two-way loudspeaker system, capable of extremely high sound pressure levels, and designed to give you the best performance of any loudspeaker in its class and price range.

Mackie Designs' entry into the sound reinforcement loudspeaker market began with the acquisition of Radio Cine Forniture (RCF), headquartered in Reggio Emilia, Italy. RCF has a long tradition in developing speaker technology for the high-end pro-audio market.

The Transducers

The C300 features a 12" high-power low-frequency woofer and a 1.75" mylar diaphragm high-output compression driver. The woofer incorporates technology used in large-format touring systems and, with a massive, precision 3-inch voice coil, is virtually indestructible.

The high-frequency compression driver is mounted on a multi-cell aperture loaded on a constant directivity horn, providing an ultra-wide, controlled dispersion pattern and precise reproduction of the critical upper mid-range and high-frequencies. The result is an unbelievably smooth off-axis response that allows everyone in the audience to experience the same high-resolution audio no matter where they are seated.

Each driver has been specifically designed by our engineers for optimum performance in a lightweight high-strength cabinet.

The Crossover

This unique Low Impedance Compensated Crossover (LICC) design places inductors in series with the woofer whose values are markedly lower than conventional designs. This reduces the amount of energy that is typically wasted as heat and increases the amount of energy that is transformed into real acoustic power. It also incorporates dynamic protection for the compression driver from non-linear signals.

The Cabinet

The C300 cabinet was designed to be the strongest molded composite cabinet on the planet. This material is as strong as concrete, and rigid enough to prevent unwanted vibrations and standing waves in the cabinet. It has built-in fly points for hanging, and a socket in the bottom for mounting on a tripod stand. Although it is an exceptional choice for installed sound situations, its light weight and durable finish also make it ideal for portable sound system use. The asymmetrical trapezoidal design of the cabinet also makes it easy to use as a floor wedge for stage monitor applications.

The C300 offers a portable, lightweight solution for a variety of high-powered sound reinforcement applications.

Inputs

The C300 input is a Speakon connector, wired as follows:

Pin 1 + is Positive (+)

Pin 1- is Negative (-)

(Pins 2- and 2+ are not used)

The C300i input is 1/4" TS (tip-sleeve), wired as follows:

The Tip is Positive (+)

The Sleeve is Negative (-)

Having these inputs on the C300i speakers makes them an ideal choice for use with one of our PPM-series professional powered mixers.



HOOKUP DIAGRAMS

Quick Start



Make all initial connections with the power switches OFF on all equipment. Make sure all master volume, level, or gain controls are all the way down.

1. Connect the line-level outputs from your mixing console (or other signal source) to the inputs of your power amplifier.
2. Connect the “Speaker Output” from your power amplifier (or powered mixer) to the INPUT connector on the C300.
3. Turn on your mixing console (or other signal source).
4. Turn on the amplifier. Turn up its volume or gain control(s) as recommended by the manufacturer.
5. Start the signal source, whether it be speaking into a microphone or starting a CD player. Adjust the volume controls on the mixer (or other signal source) for normal operation.

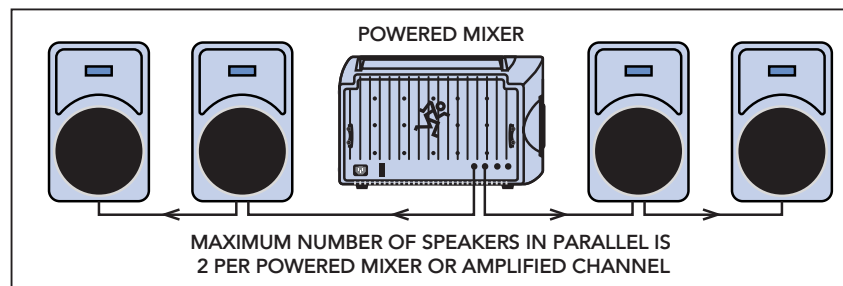

C300i: WITH A POWERED MIXER, AND USING THE THRU JACK

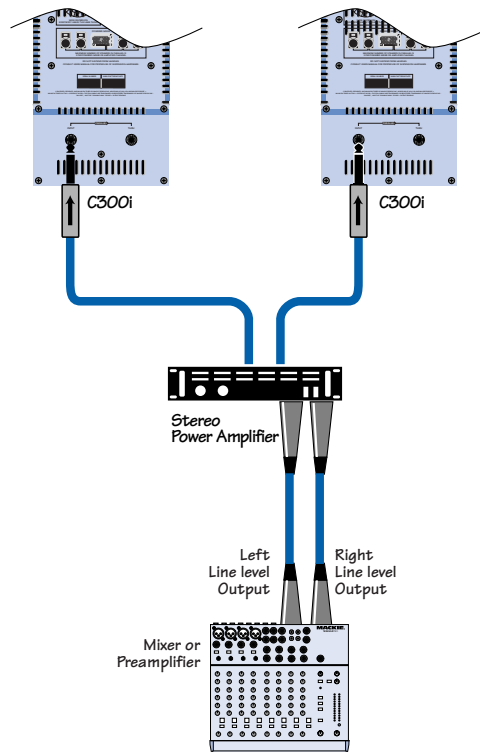

C300i: WITH A MIXER AND POWER AMPLIFIER

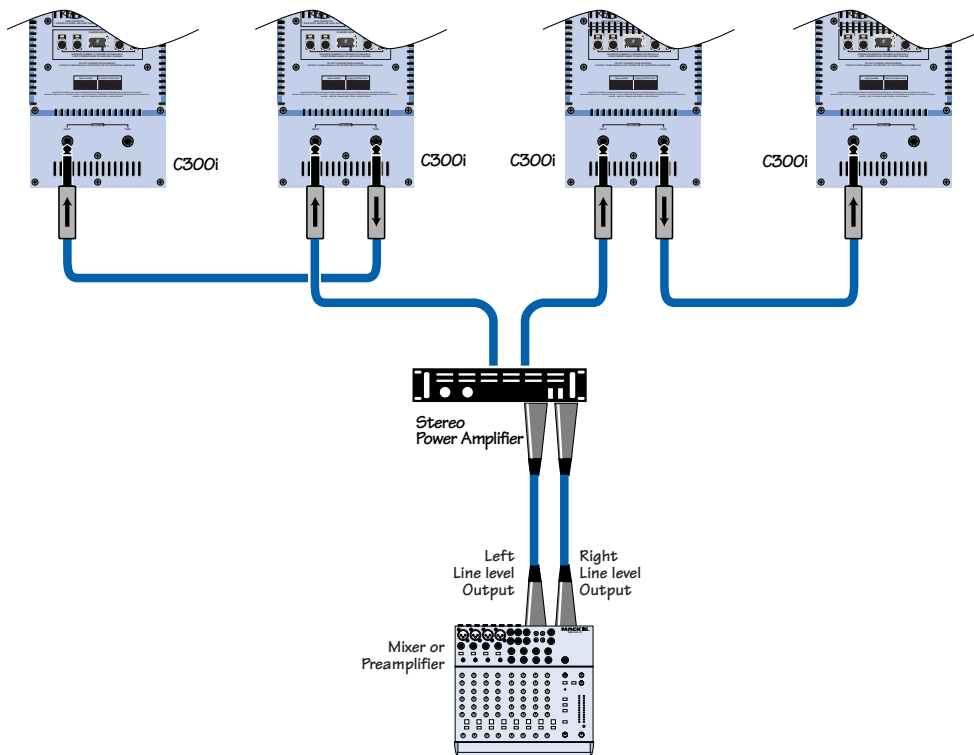

C300i: WITH A MIXER AND POWER AMPLIFIER, AND USING THE THRU JACK

The C300 can be used with a Mackie SRS1500a Subwoofer to create an incredibly powerful system.

The active crossover inside the SRS1500a splits the full-range stereo input signal into two ranges. The SRS1500a sums the left and right low-frequency range and plays it through its 600 watt amplifier and 15-inch woofer. It sends the stereo high-pass range to the C300s, via an external power amplifier.

The C300 can be pole mounted on top of the SRS1500a as shown.

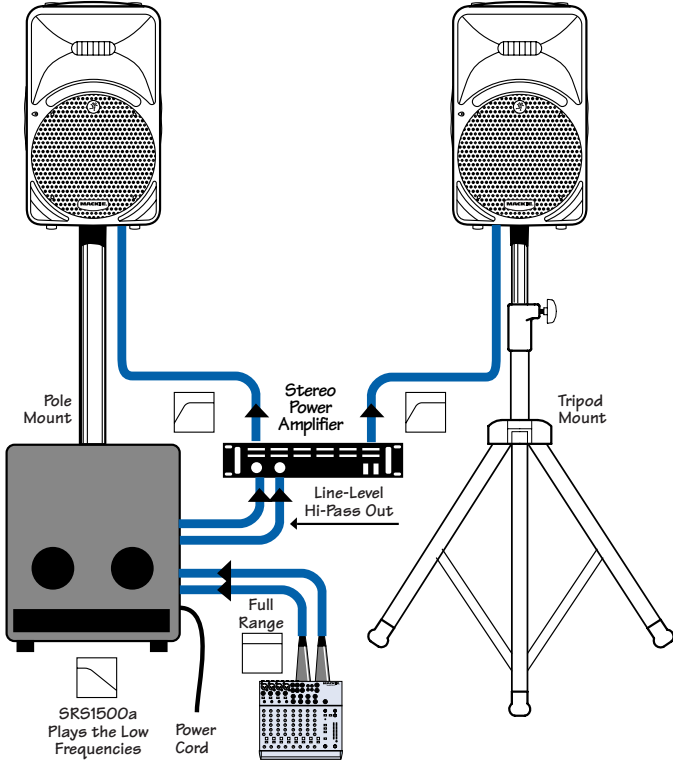

C300i: BIAMPING WITH A POWERED SUBWOOFER

PLACEMENT

The C300 loudspeakers are designed to sit on the floor, a tabletop, or to fit on a standard tripod speaker stand. They can also be suspended by the rigging points, shown here.

You can lay the cabinet down on its side and use the C300 as a floor monitor. The asymmetrical trapezoidal shape of the cabinet provides a perfect angle for aiming up toward performers from the front of the stage.



Warning: Do not stack speakers in a column. This is to avoid the danger of toppling speakers.

As with any loudspeakers, protect them from moisture. If you are setting them up outdoors, make sure they are under cover if you expect rain.

Room Acoustics

The C300 loudspeakers are designed to sound as neutral as possible; that is, to reproduce the input signal as accurately as possible, *monitoring* the audio signal rather than changing it.

Room acoustics play a crucial role in the overall performance of a sound system. However, the wide high-frequency dispersion of the C300 helps to minimize the problems that typically arise.

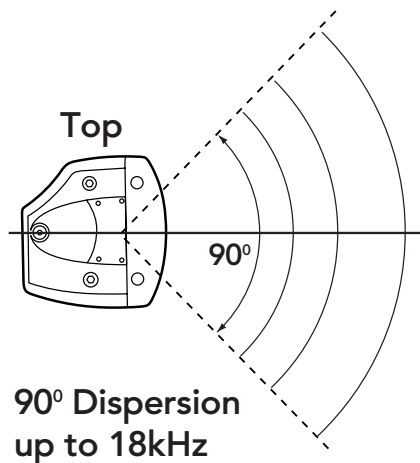

Here are some other placement tips:

- Avoid placing loudspeakers in the corners of a room. This increases the low frequency output and can cause the sound to be muddy and indistinct.

- Avoid placing loudspeakers against a wall. This, too, increases the low frequency output, though not as much as corner placement. However, if you do need to reinforce the low frequencies, this is a good way to do it.
- Avoid placing the speakers directly on a hollow stage floor. A hollow stage can resonate at certain frequencies, causing peaks and dips in the frequency response of the room. It's better to place the loudspeakers on a sturdy table or tripod stands.
- Position the loudspeakers so the high-frequency drivers are 2 to 4 feet above ear level for the audience (make allowances for a standing/dancing in the aisles audience). High frequencies are highly directional and tend to be absorbed much easier than lower frequencies. By providing direct line-of-sight from the loudspeakers to the audience, you increase the overall brightness and intelligibility of the sound system.
- Highly reverberant rooms, like many gymnasiums and auditoriums, are a nightmare for sound system intelligibility. Multiple reflections off the hard walls, ceiling, and floor play havoc with the sound. Depending on the situation, you may be able to take some steps to minimize the reflections, such as putting carpeting on the floors, closing draperies to cover large glass windows, or hanging tapestries or other materials on the walls to absorb some of the sound. However, in most cases, these remedies are not possible or practical. So what do you do? Making the sound system louder generally doesn't work because the reflections become louder, too. The best approach is to provide as much direct sound coverage to the audience as possible. The farther away you are from the speaker, the more prominent will be the reflected sound. Use more speakers strategically placed so they are closer to the back of the audience. If the distance between the front and back speakers is more than about 100 feet, you should use a delay processor to time-align the sound. (Since sound travels about 1 foot per millisecond, it takes about 1/10 of a second to travel 100 feet.)

RIGGING

The C300 cabinets are fitted with rigging points as shown in the diagram below.



WARNING: Never attempt to suspend the C300 loudspeakers by their handles. If you want to suspend them, use the rigging points only.

Full details concerning rigging the C300s can be found with Mackie's Certified Rigging Accessories, including hardware and information on safe working loads. Contact your Mackie dealer or see our website for details.

Note: Rigging should always be performed by professionals experienced in safe rigging practices.

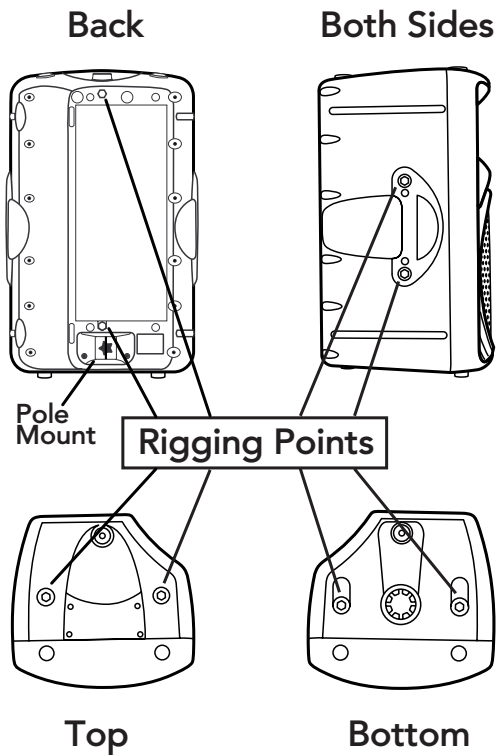

SERVICE INFO

Warranty Service

Details concerning Warranty Service are spelled out on page 11 of this manual.

If you think your loudspeaker has a problem, please do everything you can to confirm it before calling for service, including reading through the following Troubleshooting section. Doing so might save you from being deprived of your Mackie loudspeaker.

Of all Mackie products returned for service (which is hardly any at all), many are coded “CND” — Could Not Duplicate, which usually means the problem lay somewhere else in the system. These may sound obvious to you, but here are some things you can check:

Troubleshooting

No sound!

- Are the level controls on the mixer or amplifier turned all the way down? Follow the procedures in the “Quick Start” section on page 4 to verify that all the volume controls in the system are properly adjusted.
- Is the signal source working (and making union scale)? Make sure all the connecting cables are in good repair and securely connected at both ends.

One side is way louder than the other!

- Are the level controls set the same for both channels on the mixer and amplifier?
- Check the PAN control on the signal source. It may be turned too far to one side. If you’re using a stereo signal source, it may be delivering an out-of-balance stereo signal.
- Try swapping sides: Switch the speaker cables coming from the amplifier at the amplifier end. If the other side is louder now, the problem is with the amplifier, the mixer, or the signal source.

Poor bass performance

- Check the polarity of the connections between the amplifier and the loudspeakers. You may have your positive and negative connections reversed at one end of one cable.

It hurts when I touch my arm, or my leg, or even my head!

- You have a broken finger.

Bad sound!

- Is it loud and distorted? Follow the procedures described in the “Quick Start” section to verify that the levels are set properly.
- Are all the connections secure? It’s a good idea to periodically clean all electrical connections with a non-lubricating electrical contact cleaner.
- Keep practicing.

Repair

Service for the C300 is available only from one of our authorized domestic service stations or at the factory, located in sunny Woodinville, Washington. Service for loudspeakers living outside the United States can be obtained through local dealers or distributors.

If your Mackie loudspeaker needs service, follow these instructions:

1. Review the preceding troubleshooting suggestions. Please.
2. Call Tech Support at 1-800-258-6883, 7am to 5pm PST, to explain the problem and request an RA (Return Authorization) number. Have your speaker’s serial number ready. You must have an RA number before you can obtain service at the factory or an authorized service center.
3. Keep this owner’s manual. We don’t need it to repair the loudspeaker.

4. Pack the loudspeaker in its original package, including protective wrap, endcaps and box. This is very important. *Do not use styrofoam peanuts!* When you call for the RA number, please let Tech Support know if you need new packaging. Mackie is not responsible for any damage that occurs due to non-factory packaging.
5. Include a legible note stating your name, shipping address (no P.O. boxes), daytime phone number, RA number, and a detailed description of the problem, including how we can duplicate it.
6. Write the RA number in **BIG PRINT** on top of the box.
7. Ship the loudspeaker to us. We recommend United Parcel Service (UPS). We suggest insurance for all forms of cartage. Ship to this address:

Mackie Designs
SERVICE DEPARTMENT
16220 Wood-Red Rd. NE
Woodinville, WA 98072

8. We'll try to fix the loudspeaker within three business days. Ask Tech Support for the latest turnaround times when you call for your RA number. We normally send everything back prepaid using UPS BLUE (Second Day Air). However, if you rush your loudspeaker to us by Next Day Air, we'll treat it in kind by shipping it back to you UPS RED (Next Day Air). This paragraph does not necessarily apply to non-warranty service.

CARE AND MAINTENANCE

Your Mackie loudspeakers will provide many years of reliable service if you follow these simple guidelines:

- Avoid exposing the loudspeakers to moisture. If they are set up outdoors, be sure they are under cover if you expect rain.
- Avoid exposure to extreme cold (below freezing temperatures). If you must operate the loudspeakers in a cold environment, warm up the voice coils slowly by sending a low-level signal through them for about 15 minutes prior to high-power operation.
- Use a damp cloth with a mild soap solution to clean the cabinets. Avoid getting moisture into any of the openings of the cabinet, particularly where the drivers are located.

SPECIFICATIONS

Transducer Specifications

Low-Frequency Transducer

<i>Diameter</i>	300mm (12")
<i>Voice Coil Diameter</i>	175mm (3")
<i>Sensitivity (1W@1m)</i>	98 dB
<i>Nominal Impedance</i>	8 ohms
<i>Power Handling</i>	300 watts
<i>Frequency Range</i>	50Hz – 3000Hz

High-Frequency Driver and Horn

<i>Diaphragm Diameter</i>	44.5mm (1.75")
<i>Exit Throat Diameter</i>	24.5mm (1")
<i>Diaphragm Material</i>	Mylar
<i>Sensitivity (1W@1m)</i>	106 dB
<i>Nominal Impedance</i>	8 ohms
<i>Power Handling</i>	150 watts
<i>Frequency Range</i>	1000Hz – 20,000Hz
<i>Horn Type</i>	Composite: Exponential and Conical
<i>Mouth Size</i>	304.8mm (12") W x 177.8mm (7") H
<i>Horizontal Coverage</i>	90° ± 10° (1kHz – 20kHz)
<i>Vertical Coverage</i>	45° ± 10° (2.8kHz – 20kHz)

System Specifications

<i>Input Type (C300i)</i>	1/4-inch phone jack
<i>Input Type (C300)</i>	Speakon®
<i>Input Impedance</i>	8 ohms
<i>Maximum Input Power</i>	300 watt
<i>Enclosure Alignment</i>	Sixth-Order
<i>Over-Excursion Protection</i>	Second-Order High-Pass Filter
<i>Acoustic Frequency Response</i>	45Hz – 20,000Hz
<i>Low-Frequency -3 dB Point</i>	55Hz
<i>Maximum SPL @ 1m</i>	126 dB
<i>Low-Frequency Crossover Type</i>	24 dB/octave, time offset corrected
<i>High-Frequency Crossover Type</i>	24 dB/octave
<i>Crossover Frequency</i>	1800Hz
<i>Driver Protection</i>	Dynamic protection for compression driver
<i>Operating Temperature Range</i>	-10°C - 45°C (14°F - 113°F)

Physical Properties

<i>Height</i>	66.0cm (25.98")
<i>Width</i>	39.6cm (15.58")
<i>Depth</i>	37.5cm (14.75")
<i>Weight</i>	19.5kg (43lbs.)
<i>Enclosure Geometry</i>	Asymmetrical Trapezoidal
<i>Mounting Methods</i>	Integrated mounting points (10mm x 1.25mm) Two each located on each side, top, bottom, and rear of enclosure

Disclaimer

Since we are always striving to make our products better by incorporating new and improved materials, components, and manufacturing methods, we reserve the right to change these specifications at any time without notice.

“Mackie” and the “Running Man” figure are trademarks or registered trademarks of Mackie Designs Inc.

All other brand names mentioned are trademarks or registered trademarks of their respective holders, and are hereby acknowledged.

©1999 Mackie Designs Inc.

All Rights Reserved.

Printed in the U.S.A.





C300/C300i LIMITED WARRANTY

Please keep your sales receipt in a safe place.

A. Mackie warrants all materials, workmanship and proper operation of this C300 for a period of **one year** from the original date of purchase. If you complete the optional questionnaire portion of the Product Registration Card, the warranty will be extended for an **additional FOUR years** with the following exception: warranty on all its loudspeaker components including woofers and compression drivers are only warranted for an additional one year (for a total of two years). If any defects are found in the materials or workmanship or if the product fails to function properly during the applicable warranty period, Mackie, at its option, will repair or replace the product. **This warranty applies only to equipment sold and delivered within the U.S. by Mackie or its authorized dealers.**

B. Failure to return the card will not void the 1-year warranty.

C. Service and repairs of Mackie products are to be performed **only** at the factory (see D below) OR at an Authorized Mackie Service Center (see E below). Unauthorized service, repairs, or modification will void this warranty.

D. To obtain factory service:

1. Call Mackie at **800/258-6883**, 7AM to 5PM Monday through Friday (Pacific Time) to get a Return Authorization (RA). Products returned without an RA number will be refused.

2. Pack the C300 in its original shipping carton. If you do not have the carton, just ask for one when you get your RA number, and we'll send a shipping carton out promptly. More information on packing can be found in the *Service* section of this manual. Also include a note explaining exactly how to duplicate the problem, a copy of the sales receipt with price and date showing, and your return street address (no P.O. boxes or route numbers, please!). If we cannot duplicate the problem at the Mackie Factory or establish the starting date of your Limited Warranty, we may, at our option, charge for service time.

3. Ship the product in its original shipping carton, **freight prepaid** to:

**Mackie Designs Inc.
SERVICE DEPARTMENT
16220 Wood-Red Road NE
Woodinville, WA, 98072, USA**

IMPORTANT: Make sure that the RA number is plainly written on the shipping carton.

E. To obtain service from an Authorized Mackie Service Center:

1. Call Mackie at 800/258-6883, 7AM to 5PM Monday through Friday (Pacific Time) to get:

1) The name and address of your nearest Mackie Authorized Service Center and 2) A return authorization (RA). You must have an RA number before taking your unit to a service center.

2. Make sure that you have a copy of your active monitor's sales receipt from the store where you bought the product. It is necessary to establish purchase date and thus determine whether or not your active monitor is still under warranty. If you can't find it, the Authorized Service Center may charge you for repairs even if your active monitor is still covered by Mackie's 1-Year Limited Warranty.

3. Make sure that the problem can be duplicated. If you bring your active monitor to an Authorized Service Center and they can't find anything wrong with it, you may be charged a service fee.

4. If the Mackie Authorized Service Center is located in another city, pack the active monitor in its original shipping carton. More information on packing can be found in the *Service* section of this manual.

5. Contact the Mackie Authorized Service Center to arrange service or bring the active monitor to them.

F. Mackie and Mackie Authorized Service Centers reserve the right to inspect any products that may be the subject of any warranty claims before repair or replacement is carried out. Mackie and Mackie Authorized Service Centers may, at their option, require proof of the original date of purchase in the form of a dated copy of the original dealer's invoice or sales receipt. Final determination of warranty coverage lies solely with Mackie Designs Inc. or its Authorized Service Centers.

G. Mackie active monitors returned to Mackie and deemed eligible for repair or replacement under the terms of this warranty will be repaired or replaced within thirty days of receipt by Mackie at our rainforest factory complex. Products returned to Mackie that do not meet the terms of this Warranty will be repaired and returned C.O.D. with billing for labor, materials, return freight, and insurance. Products repaired under warranty at Mackie's factory will be returned freight prepaid by Mackie to any location within the boundaries of the USA.

H. Mackie assumes no responsibility for the quality or timeliness of repairs performed by Mackie Authorized Service Centers.

I. This warranty is extended to the original purchaser and to anyone who may subsequently purchase this product within the applicable warranty period.

J. This is your sole warranty. Mackie does not authorize any third party, including any dealer or sales representative, to assume any liability on behalf of Mackie Designs or to make any warranty for Mackie Designs.

K. THE WARRANTY GIVEN ON THIS PAGE IS THE SOLE WARRANTY GIVEN BY MACKIE AND IS IN LIEU OF ALL OTHER WARRANTIES, EXPRESS AND IMPLIED, INCLUDING THE WARRANTIES OF MERCHANTABILITY AND FITNESS FOR A PARTICULAR PURPOSE. THE WARRANTY GIVEN ON THIS PAGE SHALL BE STRICTLY LIMITED IN DURATION TO ONE YEAR FROM THE DATE OF ORIGINAL PURCHASE FROM AN AUTHORIZED MACKIE DEALER. UPON EXPIRATION OF THE APPLICABLE WARRANTY PERIOD, MACKIE SHALL HAVE NO FURTHER WARRANTY OBLIGATION OF ANY KIND. MACKIE SHALL NOT BE LIABLE FOR ANY INCIDENTAL, SPECIAL, OR CONSEQUENTIAL DAMAGES THAT MAY RESULT FROM ANY DEFECT IN THE MACKIE PRODUCT OR ANY WARRANTY CLAIM. Some states do not allow exclusion or limitation of incidental, special, or consequential damages or a limitation on how long warranties last, so some of the above limitations and exclusions may not apply to you. This warranty provides specific legal rights and you may have other rights which vary from state to state.