

Selecting Analog and/or Digital Input

The 300L is factory set to run Analog In at 48kHz. To change the Analog Sampling rate, to slave-lock the 300L to an external digital device, or to external system word clock, press CTRL to enter Control mode. Press PAGE until the following set of controls appear on the LARC slider display.

This page allows you to view the current status of the box, (STA), define sample clock speed (CLK), specify a digital Input connector (DIN), and select Input type (INP), output type (OUT) and digital output format (OFMT). Use the sliders beneath each label to make selections.

View the current status of system parameters.



Select AES or S/PDIF digital output format.

Press the button under the CLK slider to show the current analog clock sample rate. Use the slider to select a new rate.

Before setting the 300L to receive Digital Word Clock, use the DIN slider to designate one digital input connector (XLR, RCA or Optical) as the master for the system.

The INP slider selects Input type:

- Single ANALOG, DIGITAL, ANA + DIG.
- Dual Mono ANALOG, DIGITAL, ANA-A DIG-B, ANA-B DIG-A
- Cascade ANALOG, DIGITAL.

In Split modes, the OUT slider allows selection of unused analog or digital outputs as patch points. (Selecting a patch point with this slider requires a return input in order for the unit to continue passing audio.)

Setups

The 300L is organized into Setup Presets and User Registers. Setups contain input routing, analog and digital levels and balances, LFO rates and shapes, DSP effect configuration, and pointers to one or more effects. The SETUP key accesses this top level of the user interface.

To simplify the choice among the many possible effect and system routings, the 300L is shipped with 150 Setup Presets.

The Setup Presets are organized as follows:
 P1-100 = Single Setups
 P101-125 = Dual Mono Setups
 P126-150 = Cascade Setups
 All of the Setups are listed on the reverse side of this card.

Single Setups

Single Setups (P1-100) unify both Machine A and Machine B into a single DSP engine.

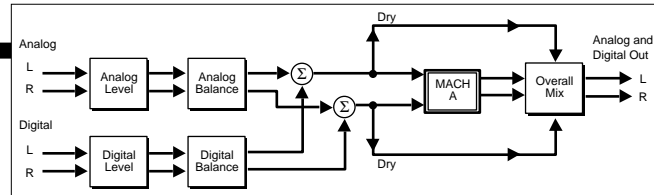

All Single Setup Presets are factory loaded with a program of the same name.

Split Setups

Dual Mono Setups (P101-125) load one effect into Machine A (left out) and one into Machine B (right out).

When only one input is selected (analog or digital), the format is referred to as "fixed". When both analog and digital are specified to operate as main inputs, the format is referred to as "mixed".

Cascade Setups also load two effects: one is loaded into Machine A, then the audio from Machine A is passed to Machine B.

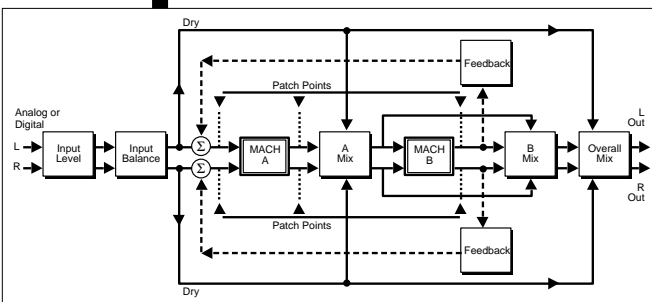
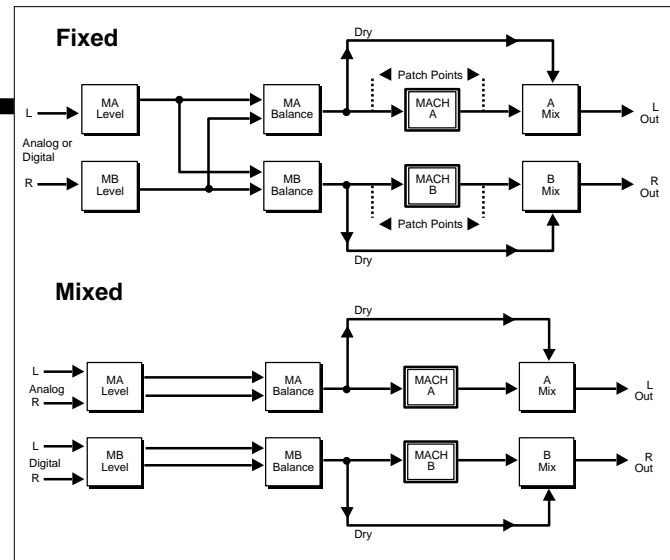

300L Quick Reference Guide

Setup Selection and SoftSlider

Press **SETUP** to display the currently running Setup. Use the PRE slider or numeric keypad entry to select a new Setup.

Press **ENTER** to load the selected Setup. Use the SoftSlider to quickly modify the sound of the Effect.

Editing a Program or Register

Press **BANK**, **PROG** or **REG** to access a page of Effect parameters.

Press **PAGE** to view additional parameter pages. Use the LARC sliders to control the parameters shown on each page.

Storing your changes into Setups

If you modify the SoftSlider setting, or any parameter, press **SETUP** to return to the top level of the user interface.

Press **STORE**. Use the REG slider to select an "available" register (or one you don't mind overwriting).

Press **STORE** again.

Note: If the 300L Copy function is disabled, no STORE functions can be performed. This function is enabled in CTRL mode (page 3, Slider 1). Selection of CTRL does not interrupt audio operation of the 300L.

Single Setup Presets

#	Name	SoftSlider	#	Name	SoftSlider
P1	LARGE HALL	DECAY	P51	LIVEDRUMROOM	IMPACT
P2	MEDIUM HALL	DECAY	P52	ON STAGE	LIVENESS
P3	SMALL HALL	DECAY	P53	GUITAR CAVE	DECAY
P4	SYNTH HALL	LIVENESSL	P54	DRUM CAVE	DECAY
P5	DANCE HALL	LIVENESS	P55	BALLROOM	SIZE / SHAPE
P6	SOLO HALL	DECAY	P56	SCORE STAGE	LIVENESS
P7	CHURCH	DEPTH	P57	DRUM GATE	DURATION
P8	GOTHIC HALL	DEPTH	P58	LE GATE!	HIGH CUT
P9	GATED HALL	SIZE	P59	THIN LIZZY	SIZZLE
P10	DEEP END	HOW DEEP?	P60	BAND IN ROOM	LIVENESS
P11	ROOMS	SIZES	P61	SPACE & EKOZ	BLEND
P12	REHURSAL ROOM	PADDING	P62	VOCAL STAGE	DECAY
P13	STUDIO A	LIVENESS	P63	WAVE O WALLS	DECAY
P14	STUDIO B	LIVENESS	P64	BRAND "X"	DECAY
P15	STUDIO C	LIVENESS	P65	HANGAR	HIGH CUT
P16	LARGE ROOM	LIVENESS	P66	EARLY REFLEX	SPACING
P17	SMALL ROOM	LIVENESS	P67	STAGE SLAP	PREDELAY
P18	BEDROOM	REFLEXIONS	P68	HUGE SPACE	DECAY LEVEL
P19	W.C.	DECAY	P69	VOCAL SHEEN	SPACE
P20	INVERSE ROOM	DURATION	P70	ALMOST VERB	PREDELAY
P21	CHAMBER	DECAY	P71	RICH PLATE	DECAY
P22	BRICK WALL	DIFFUSION	P72	GLOSSY PLATE	DECAY
P23	OIL DRUM	TUNING	P73	WARM PLATE	DECAY
P24	WIDE CHAMBER	DECAY	P74	PERC PLATE	SIZE
P25	FAT CHAMBER	DECAY	P75	CONTEM-PLATE	DECAY
P26	CHUNKY	CHUNK	P76	EKO PLATE	EKO DELAY
P27	HOMEROOM	DECAY	P77	5K HALL	DECAY
P28	OPEN WIDE	DECAY	P78	ROUND PLATE	DECAY
P29	WET SUIT	DECAY	P79	SALAD PLATE	DECAY
P30	BASEMENT	LIVENESS	P80	VOX PLATE	DECAY
P31	AMBIENCE	SIZES	P81	STEREOADJUST	LEVEL
P32	MARBLE FOYER	SLAP LEVEL	P82	STEREO DELAY	DELAY
P33	LARGE AMB.	HIGH CUT	P83	3 FRAME DLY	FINE DELAY
P34	MEDIUM AMB.	HIGH CUT	P84	4 FRAME DLY	FINE DELAY
P35	SMALL AMB.	HIGH CUT	P85	PHASE INVERT	PHASE
P36	V SMALL AMB.	HIGH CUT	P86	MS DECODE	MATRIX M/S
P37	HEAVY AMB.	REVERB LVL	P87	TELEPHONE	LEVEL
P38	BRIGHT AMB.	REVERB LVL	P88	MULTI CANYON	DEPTH
P39	SMOOTH AMB.	HOW SMOOTH?	P89	LFO PANNER	LFO SPEED
P40	WAVE AMB.	HOW LONG?	P90	THIN EKOZ	FEEDBACK
P41	IN A ROOM	HOW BIG?	P91	STEREO SHIFT	SHIFT DN/UP
P42	STAIRWELL	# OF FLOORS	P92	OCTAVE DOWN	FINE PITCH
P43	CAR INTERIOR	WINDOW DN/UP	P93	VOX CHORUS	SPLIT SHIFT
P44	MEETING ROOM	LIVENESS	P94	POLE FLANGE	FEEDBACK
P45	LIVING ROOM	LIVENESS	P95	BULKIE ROLL	DELAY
P46	POWDER ROOM	DECAY	P96	MR. BIG	FINE PITCH
P47	FULL CLOSET	HOW FULL?	P97	ZORCH!	FEEDBACK
P48	PODIUM	DISTANCE	P98	GOING, GOING	FEEDBACK
P49	STUDIO D	HIGH CUT	P99	GTR CHORUS	FINE PITCH
P50	OFFICE	LIVENESS	P100	FADE DOWN	FINE PITCH

Dual Mono Setup Presets

#	Name	SoftSlider
P101	DM: REV/REV	INPUT PAN
P102	DM: REV/DLY	INPUT PAN
P103	DM: REV/PCH	INPUT PAN
P104	DM: REV/COMP	INPUT PAN
P105	DM: DLY/DLY	LFO RATE
P106	DM: DLY/PCH	DELAY MACH A
P107	DM: DLY/COMP	SPACE MACH A
P108	DM: PCH/PCH	INPUT PAN
P109	DM: PCH/COMP	INPUT PAN
P110	DM: COMP/COMP	INPUT PAN
P111	DM: SLOW SPIN	LFO RATE
P112	DM: WIDEFLANG	LFO RATE
P113	DM: X-TRAFFIC	DELAY MACH B
P114	DM: GEAR UP	INPUT PAN
P115	DM: TWO ROOMS	INPUT PAN
P116	DM: TWO HALLS	INPUT PAN
P117	DM: DELAYS	DELAY SPACE
P118	DM: REVPAN	DECAY TIME
P119	DM: UP&DOWN	DELAY
P120	DM: MYGUITAR	INPUT PAN
P121	DM: ENVSPOOGE	INPUT PAN
P122	DM: FLNG&DLYS	DELAY MACH B
P123	DM: DLY DAZE	DELAY
P124	DM: CLUSTERS	DELAY MACH B
P125	DM: 2 FLANGES	INPUT PAN

Cascade Setup Presets

#	Name	SoftSlider
P126	CC: REV->DLY	DELAY SPACE
P127	CC: DLY->REV	SLAP & SIZE
P128	CC: REV->PCH	DECAY MACH A
P129	CC: PCH->REV	BMIX
P130	CC: REV->COMP	THRESHOLD
P131	CC: COMP->REV	NONE
P132	CC: DLY->PCH	LFO RATE
P133	CC: PCH->DLY	DELAY SPACE
P134	CC: DLY->COMP	DELAY SPACE
P135	CC: SLAPS	SPACE
P136	CC: PCH->COMP	LFO RATE
P137	CC: SURRVERB	SPATIAL EQ
P138	CC: V3COMP	NONE
P139	CC: EQ/DITHER	NONE
P140	CC: FILT DLYS	DLY/BANDPASS
P141	CC: JETVERB	LFO RATE
P142	CC: BIGBRICKS	DIFFUSION
P143	CC: REV->EKOZ	RVB LEVEL
P144	CC: REV->KORUS	RVB LEVEL
P145	CC: OVERITOP	LFO RATE
P146	CC: GUITAR XP	LFO RATE
P147	CC: EKO->FAZE	AMIX
P148	CC: VERB->DOWN	B MIX
P149	CC: THE SKY	DELAYS
P150	CC: SPINOLA	LFO RATE

The 300L has many features which are not described here — for complete information, see the 300L Owner's Manual.

lexicon

3 Oak Park • Bedford MA 01730-1441 • Tel: (617) 280-0300 • Fax: (617) 280-0490