

**CAD**  
professional microphones

# E350

Large Diaphragm  
Studio Condenser  
Microphone



*Featuring the CAD  
Optema™ OS 110  
Condenser Capsule*

Specifications  
and User's Guide

Equitek



Professional Microphones

## Equatek E-350

The Equitek E-350 combines a vintage capsule design with advanced electronics. Typical FET (field effect transistor) condenser microphones use discrete designs. This means they use individual transistors that must be carefully matched for proper characteristics. Even with careful matching, discrete designs are inherently nonlinear. Equitek microphones use a different approach. We do not use any discrete FETs. Instead, we use advanced high speed OpAmps (Operational Amplifiers). These OpAmps are individually laser trimmed for optimum performance and have very high gain. This allows a large amount of negative feedback to be used to significantly reduce any non-linearity. During transients, these OpAmps may require more current than typical phantom power supplies can deliver. The extra current demands are accommodated by our unique power supply design. Instead of using phantom power to operate the microphone, we use it to charge a pair of rechargeable batteries. This system creates a huge current reserve for the microphone's electronics, yet there is no maintenance involved because the microphone automatically keeps the batteries charged during use. The use of OpAmps is not the only unique feature of Equitek microphones. For example, we also employ servo circuitry to minimize dc offset and eliminate interstage coupling capacitors. The bottom line is we believe you will find the Equitek E-350 to have a remarkably open and clean sound

Bob Eaton  
Senior Microphone Engineer

Made with pride in Conneaut,  
Ohio U.S.A.

## Description

The Equitek E-350 from Conneaut Audio Devices is a multi-pattern side address microphone designed for professional recording and broadcast applications. The implementation of high speed, low noise, low distortion electronics makes the Equitek E-350 the ideal candidate for the most critical applications.

The Equitek E-350 incorporates a number of unique features including:

- Large 1.1" Dual Diaphragm External Bias Condenser Capsule.
- Gold Sputtered Diaphragms.
- Servoed head amplifiers.
- High SPL Capability (148 dB SPL with pad)
- Transformerless balanced output circuits.
- Internal power reservoir system that can supply ten times the current available from phantom powering alone.
- Remote operation without phantom power using internal batteries.
- 20 dB non capacitive pad
- Stainless steel internal pop/EMI filter.

## Switch Functions

### Power



- 1 = Microphone Power On
- 0 = Microphone Power Off (Use this switch position for fastest charging of batteries.)

### Hi-Pass



- Left position = Low end roll off below 80 Hz.
- Right Position = Flat low end response.

### Pattern



- = Omnidirectional Pattern
- ◐ = Cardioid Pattern
- 8 = Figure 8 Pattern

### Pad



- 0dB = Full gain (Highest Sensitivity)
- 20dB = 20dB Gain reduction (Highest Clipping Level)

## Getting Started

The E-350 requires 48 volt phantom power and the internal batteries must be charged for proper operation. Although the internal batteries were charged at the factory, the batteries will gradually self-discharge if the microphone has been in storage for a long time. It may be necessary to charge the batteries before initial use. Please see the section below on powering the Equitek E-350.

## Caution!

The high gain and wide bandwidth of the E-350 microphone will easily overload the inputs of many professional mixing consoles if adequate precautions are not taken. This is especially true if the microphone is going to be used on percussion or amplified electronic instruments. If you have never used this microphone before, we strongly recommend that you initially reduce the system gain by doing one or more of the following:

- Enable the pad switch on the input of your mixing console.
- Start with the input trim control on your mixing console turned down to a low level.
- Enable the -20 dB pad switch on the E-350 microphone.

## Powering the Equitek E-350

The Equitek E-350 is powered by a combination of 48 Volt phantom power and a pair of rechargeable 9 volt batteries. This powering arrangement overcomes the inherent current limiting associated with most phantom power supplies. The batteries are trickle charged by the phantom supply. When needed, the batteries provide the extra current necessary during high SPL transients. The microphone will not function properly without the batteries present. The microphone can be used without phantom power for periods of up to 6 hours provided the batteries are fully charged. (Standard 9 volt alkaline batteries can also be used if extended operation is needed when no phantom power is available.\* (Auto power shut off circuit must be disabled for battery operation without phantom power.) The minimum requirement for the phantom supply is a regulated 48 volts with the capability of supplying at least 8 mA. of current. Supplies that do not meet this requirement will not allow continuous operation of the microphone. Before initial use, the batteries may need to be fully charged. Once the batteries have received this initial charge, they should not need to be charged in this manner again, unless the microphone is unused for a long time. The batteries can be charged by two different means:

- Connect the microphone to a phantom supply and allow the batteries to charge 12 - 14 hours with the mic turned off.
- Remove the batteries from the microphone and charge using a standard battery charger.

\* See the section on Auto Power Shut Off. IF USING ALKALINE 9 VOLT BATTERIES, DO NOT APPLY PHANTOM POWER TO THE MICROPHONE! DOING SO COULD CAUSE PERMANENT DAMAGE TO THE MICROPHONE AND VOID YOUR WARRANTY!

NOTE: If you normally operate the microphone from phantom power, it is best to leave the microphone power switch in the on or "1" position at all times. (The microphone automatically shuts off to conserve battery power when phantom power is removed.)

## Auto Power Shut Off Configuration

The Equitek E-350 incorporates a circuit which shuts the microphone off if phantom power is removed. This is done so that battery power will be conserved if the user forgets to turn the microphone off. If it is desired to operate the microphone using only the batteries, this feature must be disabled or the microphone will not function. This is easily done by means of a small movable configuration jumper located inside the microphone. To gain access to the inside of the microphone, remove the XLR end cap by first removing the two screws. Then, loosen the screw on the back of the microphone and slide off the microphone housing. The jumper is labeled JP1 and is located next to the battery holder on the side of the card opposite the XLR connector. The jumper shorts two of three available pins to select the proper mode. From the factory, the two pins towards the "A" are shorted to enable the auto shut off circuit. To disable the circuit, pull off the jumper and replace it so that the two pins towards the "M" (For manual mode) are shorted. The microphone can be used with phantom power when it is in this mode, however you must remember to turn the microphone off when not in use or the batteries will be depleted.

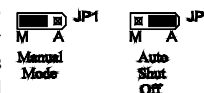

Bob Eaton  
Senior Microphone Engineer

Made with pride in Conneaut,  
Ohio U.S.A.

# User Techniques and Applications

The Equitek E-350 can be used in a broad number of applications, ranging from live reinforcement to the most critical studio situations. The E-350 is ideal for vocals and voice overs, yet it also excels at some of the most demanding instrumental projects. The E-350 is great for virtually all acoustic, wind, and amplified instruments. It will even handle the explosive dynamics of drum kits with ease. The E-350 has been proven to be outstanding in all of these applications and more. Its uncolored sonic characteristics allow you to decide how a instrument or vocal will sound in the mix.

## Specifications

### Type:

Side Address, External bias condenser

### Frequency Response:

10-20 kHz

### Polar Patterns:

Cardioid, Figure eight, Omnidirectional

### Impedance:

Low (200 ohms nominal).

### Output Level At 1 kHz.:

#### Power Level:

-34 dB (0 dB = 1 mW per 10 microbars).

#### Open Circuit Voltage:

-55 dB (0 dB = 1 volt per microbar).

17.8 mV/Pascal.

### Dynamic Range:

137 dB.

### Equivalent Noise Level:

11 dB Equivalent SPL, A weighted

### Maximum Output Level:

With pad, .89 dBV

Without pad, 8.9 dBV

### Maximum SPL:

148 dB SPL (With pad on)

### Total Harmonic Distortion:

Less than 0.15%

### Signal-To-Noise Ratio:

83 dB (At 94 dB SPL)

### Capsule Capacitance:

65 pF

### Powering:

Minimum Requirements are 48 - 52 Volts Phantom Power capable of delivering at least 8 mA.

### Included Accessories:

ZM-1G ... Shock Mount (See cover photo)

### Optional Accessories:

SM-1 ..... Swivel Mount

WS-1 ..... Foam Windscreen

40-350 ... 50 ft. broadcast quality extension cable terminated with professional 3 pin male/female connectors



OS-110 Capsule

## Optema™ Series, OS-110 Dual Diaphragm Condenser Capsule

The OS-110 condenser capsule is the standard capsule supplied with the E-350 microphone. OS-110 capsules are produced in a state-of-the-art cleanroom at our condenser capsule production facility in Conneaut, Ohio. The OS-110 capsule has the following features:

- True large diameter capsule with 1.1" inside diameter. (1.3" outside diameter.)
- 3 Micron thick high tension, diaphragms made from the latest high strength polymer film.
- 24K Gold sputtered diaphragm coating.
- Each capsule is hand adjusted for proper damping and consistent frequency response.
- Other capsule components made from precision machined brass and stainless steel.

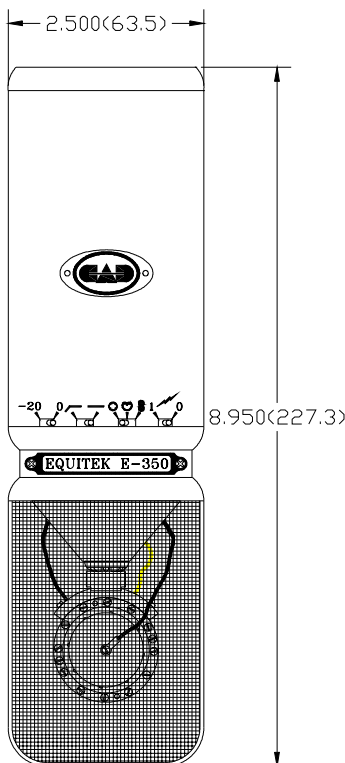

## Equitek E-350 Schematic

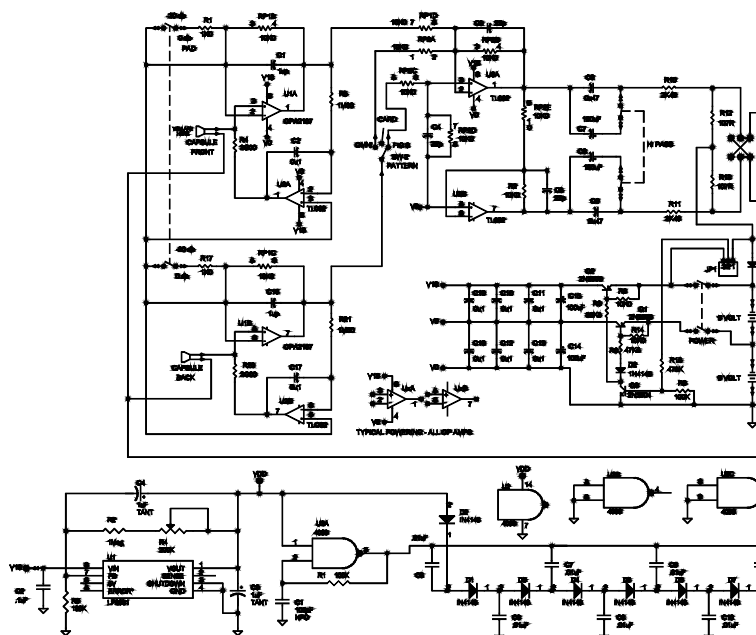

## Equitek E-350 Frequency and Polar Response

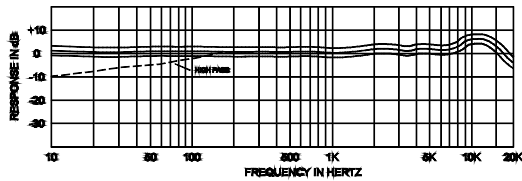
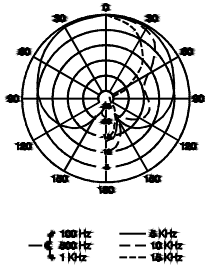

**Cardioid**

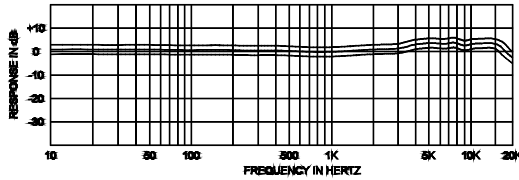
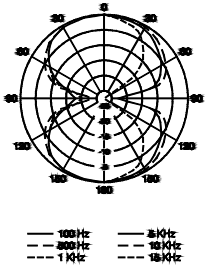

**Figure 8**

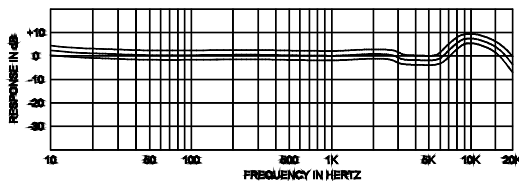
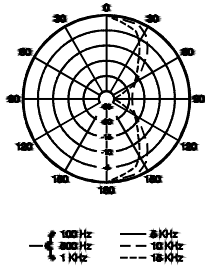

**Omnidirectional**

## ZM-1G Equitek shock mount

### Description

The CAD ZM-1G is a full elastic suspension system for shock isolating all CAD Equitek cylindrical multi-pattern microphones. The ZM-1G eliminates mechanical shock interference that is transmitted through the microphone stand by footsteps, machinery, or other vibration sources. The ZM-1G also incorporates a built in swivel for ease of microphone positioning. The ZM-1G attaches to microphone stands with a standard 5/8" x 27 thread.

### Mounting a microphone in the ZM-1G

Unscrew the small knurled adapter and rubber ring from the large knurled knob as shown in **Figure 1**. Screw the adapter and ring snugly into the bottom of the microphone as shown in **Figure 2**. Slide the microphone into the mount and screw the knurled knob back into the adapter as shown in **Figure 3**. Make certain that the microphone is positioned as shown with the microphone connector centered in the opening of the metal ring. An XLR connector that is inserted into the microphone will not touch the metal frame of the ZM-1G if the microphone is positioned properly. The elastic cords in the larger ring should be positioned so that they fall in the name band area in the middle of the microphone.



**Figure 1**



**Figure 2**



**Figure 3**

## A Special Note About Batteries

The high quality rechargeable batteries used in the Equitek E-350 may either be Nickel Cadmium or Nickel Metal Hydride. They were selected to provide long life with virtually no maintenance and have a number of properties that make them superior to most commonly available rechargeable "9 volt" batteries:

- 1) Higher output voltage
- 2) Lower self discharge rate
- 3) High immunity to overcharging

If the E-350 is operated with a 48 volt phantom power supply it is unlikely they will ever need to be recharged, even if the microphone is unused for months. If it should ever become necessary to replace the batteries or if you simply want a spare set, we suggest that you buy replacements from us. This is not because we are trying to sell batteries, but because we want you to continue to realize the maximum performance capability of your Equitek microphone. Contact the CAD sales department to purchase replacement or additional batteries.

## Re-stringing the elastic cords.

Follow the instructions below if the elastic cords are removed and need to be remounted:

For the large circular ring use the elastic cord that is formed in a loop.

- 1) Using the diagram in **Figure 4**, start by placing the cord in slot #1. Position the metal clip on the underside of the ring at this position.
- 2) Using a "wrapping" motion, stretch the cord and use the number guide to install the cord.
- 3) When complete, the elastic should look like the diagram in **Figure 5**.
- 4) Adjust the elastic so that there is nearly equal tension on the individual segments.

For the smaller "C" shaped ring use the short elastic cord that has a small loop at each end.

- 1) Look at the diagram in **Figure 6** and attach the elastic cord as shown
- 2) When complete the prongs of the triangular bracket should point towards the large ring.

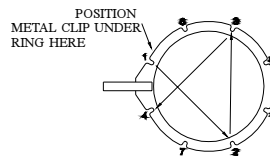

**Figure 4**

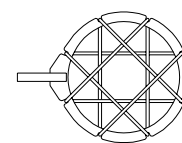

**Figure 5**

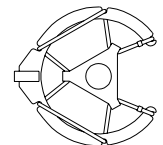

**Figure 6**

## TWO-YEAR LIMITED WARRANTY

CTI Audio, Inc. ("CAD") hereby warrants that this product will be free of defects in material and workmanship for a period of two years from the date of purchase. In the unlikely event a defect occurs CAD will, at its option, either repair or replace with a new unit of equal or greater value. You should retain proof of purchase to validate the purchase date and return it with any warranty claim. Return warranty claims carefully packed, insured and prepaid to the Service Department at the address listed below.

This warranty excludes exterior finish or appearance, damage from abuse, misuse of the product, use contrary to CAD's instructions or unauthorized repair. All implied warranties or merchantability or fitness for a particular purpose are hereby disclaimed and CAD hereby disclaims liability for incidental, special or consequential damages resulting from the use or unavailability of this product.

This warranty gives you specific legal rights and you may also have other rights which vary from state to state. Some states do not allow the exclusion or limitation of incidental or consequential damages or limitations on how long an implied warranty lasts, so the above exclusions and limitations may not apply to you.

Note: No other warranty, written or oral is authorized by CTI Audio, Inc.

